



## ARCHITECTURAL REVIEW BOARD WORK SESSION AGENDA

Herndon Council Chambers Building  
765 Lynn Street, Herndon, VA 20170

Wednesday, January 7, 2026 | 7:30 PM

---

- 1. Call to Order**
- 2. Public Hearings**
  - a. Application for new Construction, ARB #25-004
  - b. Application for Alteration to an Existing Structure, ARB #25-005
  - c. Application for new Construction, ARB #25-006
- 3. Comments**
  - a. Comments from the Staff Members
  - b. Comments from the Board Members
- 4. Adjournment**

**Agenda Item:** Application for new Construction, ARB #25-004

**Meeting Date:** January 7, 2026

**Category:** Public Hearings

**Prepared by:** Angelina Jones, Lead Planner / Design and Development

**Description:**

This application proposes to demolish and remove the existing playground structures at Harding Park and replace them with newly constructed play equipment. A portion of the existing asphalt pathway will be removed to accommodate an expanded play area. The existing wooden perimeter border will be replaced with black plastic borders. The play area will be surfaced with an engineered wood fiber mulch. Two additional benches will also be installed along the playground's perimeter. For additional information, please see the attached staff report.

**Background/Timing Impact:**

The property at 749 Van Buren Street features an approximately .48-acre public property called Harding Park. The site is improved with playground equipment in two play areas spaced about 10 feet apart in addition to other site features such as picnic tables, benches, and garbage receptacles. For additional background and case history, please see the attached staff report.

**Fiscal Impact:**

N/A

**Legal Impact:**

N/A

**Staff Recommendation/Next Steps:**

Staff recommends approval in accordance with the draft resolution.

**Attachments:**

1. Staff Report
2. Resolution (Proposed)
3. Materials

## STAFF REPORT

**Agenda Item:** ARB #25-004; New Construction; Fairfax County Tax Map 0162 02 0240, 749 Van Buren Street

**Meeting Date:** January 7, 2026

**Staff Contact:** Angelina R. Jones, Lead Planner – Development & Design

**Summary Information:**

Proposed Modification	New Construction – Playground equipment and other minor site improvements		
Address	749 Van Buren Street, Herndon, VA 20170		
Fairfax County Tax Map Number	0162 02 0240		
Owners	The Town of Herndon		
Applicant	Zeljko Spasojevic, The Town of Herndon		
Business/Organization	Harding Park/Town of Herndon		
Property Use	Public Land		
Zoning District	RM, Residential Multi-Family		
HDO Designation	N/A		
Adjacent Zoning	<b>North:</b> R-10, Residential Single-Family - 10 District	<b>East:</b> R-10, Residential Single-Family - 10 District	
	<b>South:</b> CS - Commercial Services District	<b>West:</b> CS - Commercial Services District	
Building Type(s)	N/A	<b>Date of Construction:</b>	N/A
Architectural Style(s)	N/A		
Exterior Material(s)	N/A		
Neighborhood Design Profile	Mix of multi-family and single-family residential		
Comprehensive Plan Land Use Designation	Community Facilities		

**Location Map:**

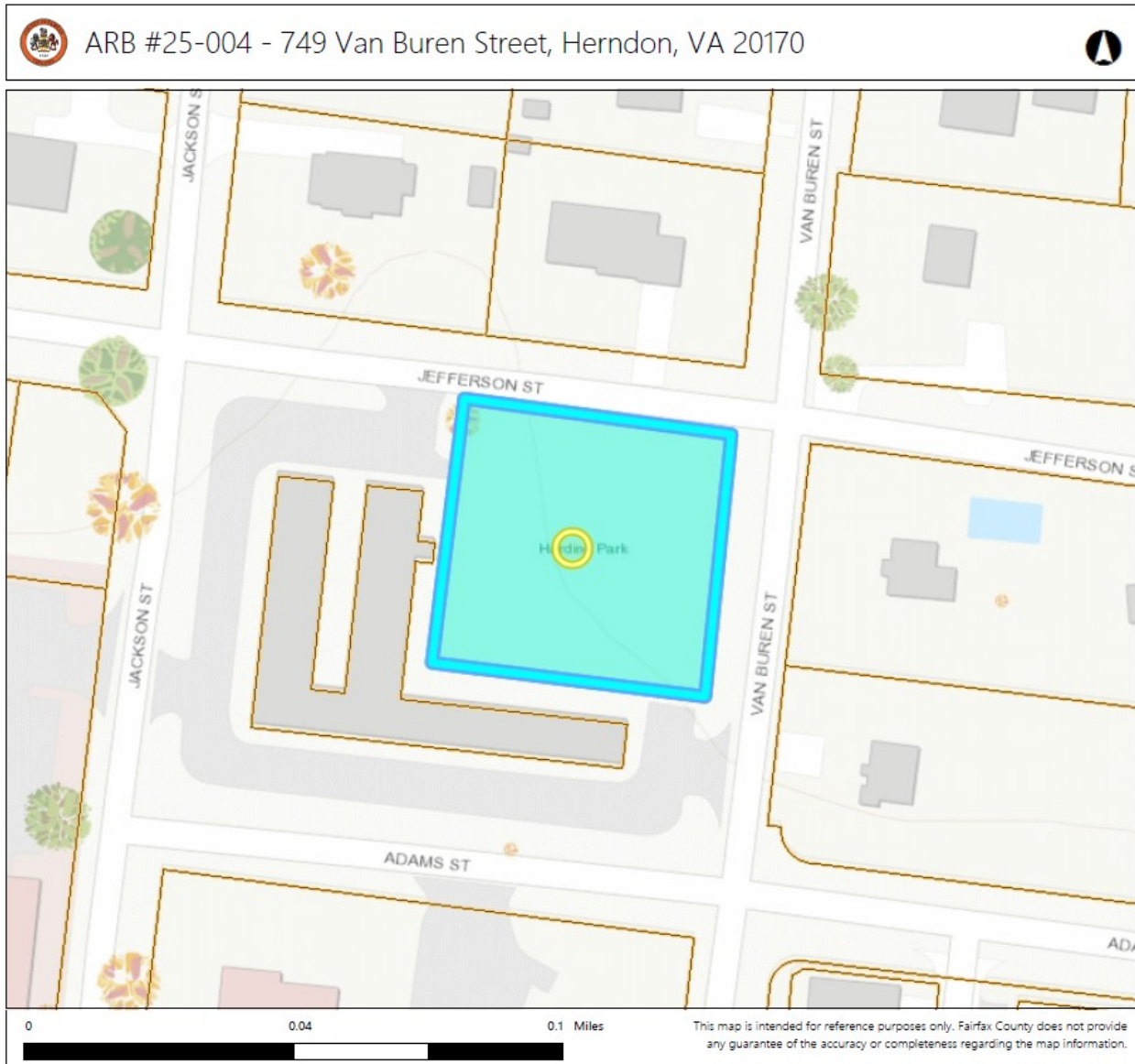

**Background Information:**

Property Description

The property at 749 Van Buren Street features an approximately .48-acre public property called Harding Park. The site is improved with playground equipment in two play areas spaced about 10 feet apart in addition to other site features such as picnic tables, benches, and garbage receptacles (*Figure 1*). The property also features several mature canopy trees. Harding Park is immediately northeast of the Gaslight Square Condominium development.



Figure 1: Present-day play area at Harding Park. Source: Google Maps, November 2024

### Applicable Land Use and Case History

The American Society of Landscape Architects (ASLA) provide useful information pertaining to industry standards for playground design. The organization identifies several factors that characterize successful playground design including that the facility provides opportunities for multiple forms of play with a range of types of sensory engagement, exposes users to the natural environment, facilitates intergenerational play, and provides accessible equipment for people of all abilities. You can read more about best practices in contemporary playground design on the ASLA’s website:

[A Brief History of Playground Design, Part 2 – The Field](#)  
[Universal Design: Playgrounds | asla.org](#)

The applicant previously applied for and received a site plan waiver for installation of the proposed playground equipment (MNP25-13). The November 2025 response to the request for a waiver is conditioned to require tree protection during construction activities and inspection of the protection measures prior to commencement of work. The waiver does not authorize any removal of landscaping (vegetation), the addition of new impervious area, or land disturbance of 2,500 square feet or more.

While no two properties within the Architectural Control District are alike and therefore previous cases at other properties do not set precedent, knowledge of similar types of projects previously heard by the ARB provide useful context for evaluation. Related cases include the following:

- ARB #14-27 – On November 17, 2014, the ARB voted to approve an application to construct a 676-square foot, prefabricated restroom and storage facility at Haley Smith Park (324 Van Buren Street). The approved building was constructed of pre-cast concrete clad with a split face block and finished with a cedar shake roof.
- ARB #23-016 – On December 20, 2023, the ARB approved an application for construction of a multi-family housing development at 1155 Herndon Parkway. The development included a prefabricated playground with a mix of plastic and metal components as part of the open space design approved by the board.

**Case Details & Proposal:**

This application proposes to demolish and remove the existing playground structures at Harding Park and replace them with newly constructed play equipment. A portion of the existing asphalt pathway will be removed to accommodate an expanded play area. The existing wooden perimeter border will be replaced with black plastic borders. The play area will be surfaced with an engineered wood fiber mulch. Two additional benches will also be installed along the playground’s perimeter.

**Staff Analysis:**

Zoning Ordinance Compliance

- Town Code of Ordinances, Section 58-96 – Design criteria
  1. Staff has found that the proposed new construction meets the applicable standards and requirements of the Town of Herndon Zoning Ordinance.
  2. With the findings expressed below, staff asserts the proposed new construction generally complies with the applicable design criteria within the Town’s Architectural Control District as specified in Section 58-96 of the Town Code of Ordinances. Staff have used these design criteria to evaluate the proposed design changes, summarized in the following table:

<b>Town Code of Ordinances, Section 58-96 – Design criteria</b>	
The board of architectural review and, on appeal, the town council shall use the following standards and criteria in considering applications filed under this article:	
1) Whether or not the proposed architectural design is suitable for a good suburban community in terms of external architectural features, including signs subject to	The proposed playground equipment and other minor site features are suitable for a good suburban community. The new playground design meets many aspects of best practice in playground design

<p>public view, general design and arrangement, texture, color, line, mass, dimension, material and lighting.</p>	<p>outlined above including multiple forms of play with a range of types of sensory engagement and accessible equipment for people of all abilities.</p>
<p>2) Whether or not the proposed structure, building or improvement is compatible with existing well-designed structures, acceptable to the board, in the vicinity and in the town as a whole.</p>	<p>The proposed improvement is of a similar scale to the existing playground equipment it is replacing. The design, massing, and configuration is appropriate for the residential setting where it will be located.</p>
<p>3) Whether or not, and to what extent, the proposed structure, building or improvement would promote the general welfare and protect the public health, safety and morals by tending to maintain or augment the town's tax base as a whole, generating business activity, maintaining and creating employment opportunity, preserving historical sites and structures and making the town a more attractive and desirable place in which to live.</p>	<p>The proposed improvement provides a safe and well-designed recreational space for the Town's residents with play equipment that meets current industry standards in terms of design and function.</p>
<p>4) Whether or not proposed freestanding buildings use the same or architecturally harmonious materials, color, texture and treatment for all exterior walls; and in the case of partially freestanding buildings, whether or not the same or architecturally harmonious materials, color, texture and treatment are used on all portions of all exterior walls exposed to public view.</p>	<p>N/A</p>
<p>5) Whether or not the combination of architectural elements proposed for a structure, building or</p>	<p>The prefabricated playground equipment and site design materials are commonly used design elements in recreational</p>

<p>improvement, in terms of design, line, mass, dimension, color, material, texture, lighting, landscaping and roofline and height conform to accepted architectural principles for permanent buildings as contrasted with engineering standards designed to satisfy safety requirements only; and exhibit external characteristics of demonstrated architecture and aesthetic durability.</p>	<p>spaces and conform with accepted architectural principles related to playground design as discussed above.</p>
<p>6) Whether or not, in terms of design, material, texture, color, lighting, landscaping, dimension, line, mass or roof line and height, the proposed structure, building or improvement is designed to serve primarily as an advertisement or commercial display, exhibits exterior characteristics likely to deteriorate rapidly, would be of temporary or short-term architectural or aesthetic acceptability, would be plainly offensive to human sensibilities or would otherwise constitute a reasonable foreseeable detriment to the community.</p>	<p>The proposed playground equipment and site features are sufficiently durable and meet current industry standards in terms of overall design and function as described above.</p>

**ARB Alternatives:**

The following alternatives are available to the ARB for its decision on #25-004.

1. Approval as proposed
2. Approval with conditions
3. Denial on specific stated grounds
4. Continuance of the application to a future public hearing

**Staff Recommendation:**

Staff recommends approval in accordance with the draft resolution.

**TOWN OF HERNDON, VIRGINIA  
ARCHITECTURAL REVIEW BOARD**

**RESOLUTION**

**January 21, 2026**

**Resolution-** to consider an application for the erection of new playground equipment and other minor site improvements at the public property located at Harding Park, 749 Van Buren Street, Herndon, Virginia, located at the intersection of Jefferson Street and Van Buren Street and further identified as Fairfax County Tax Map 0162 02 0240.

**BE IT RESOLVED** by the Architectural Review Board of the Town of Herndon, Virginia that:

1. The Architectural Review Board approves ARB #25-004, for the erection of new playground equipment and other minor site improvements at the public property located at Harding Park, 749 Van Buren Street, Herndon, Virginia, in substantial conformance with the information shown in the case materials reviewed by the ARB at the January 21, 2026, public hearing.

FOR KIDS AGES <b>2-12</b> YEARS	AGE GROUP: 12_ASTM
ELEVATED PLAY ACTIVITIES - TOTAL: 0	REQ'D 0
ELEVATED PLAY ACTIVITIES ACCESSIBLE BY TRANSFER: 0	REQ'D 0
ELEVATED PLAY ACTIVITIES ACCESSIBLE BY RAMP: 0	REQ'D 0
GROUND LEVEL ACTIVITY TYPE: 1	REQ'D 0
GROUND LEVEL QUANTITY: 4	REQ'D 0

# Harding Park - Proposal B.3

## Herndon, VA

FOR KIDS AGES <b>5-12</b> YEARS	AGE GROUP: 12_ASTM
ELEVATED PLAY ACTIVITIES - TOTAL: 8	REQ'D 4
ELEVATED PLAY ACTIVITIES ACCESSIBLE BY TRANSFER: 7	REQ'D 0
ELEVATED PLAY ACTIVITIES ACCESSIBLE BY RAMP: 0	REQ'D 0
GROUND LEVEL ACTIVITY TYPE: 7	REQ'D 3
GROUND LEVEL QUANTITY: 13	REQ'D 3

ADA 1/2 RAMP INCLUDED WITH PLASTIC BORDER SYSTEM.  
LOCATION OF RAMP TO BE IN LINE WITH EXISTING PATHWAY.

RISK MANAGEMENT SIGN - ENGLISH  
787

PARTIAL DEMO OF EXISTING PATHWAY IS INCLUDED IN PROPOSAL.

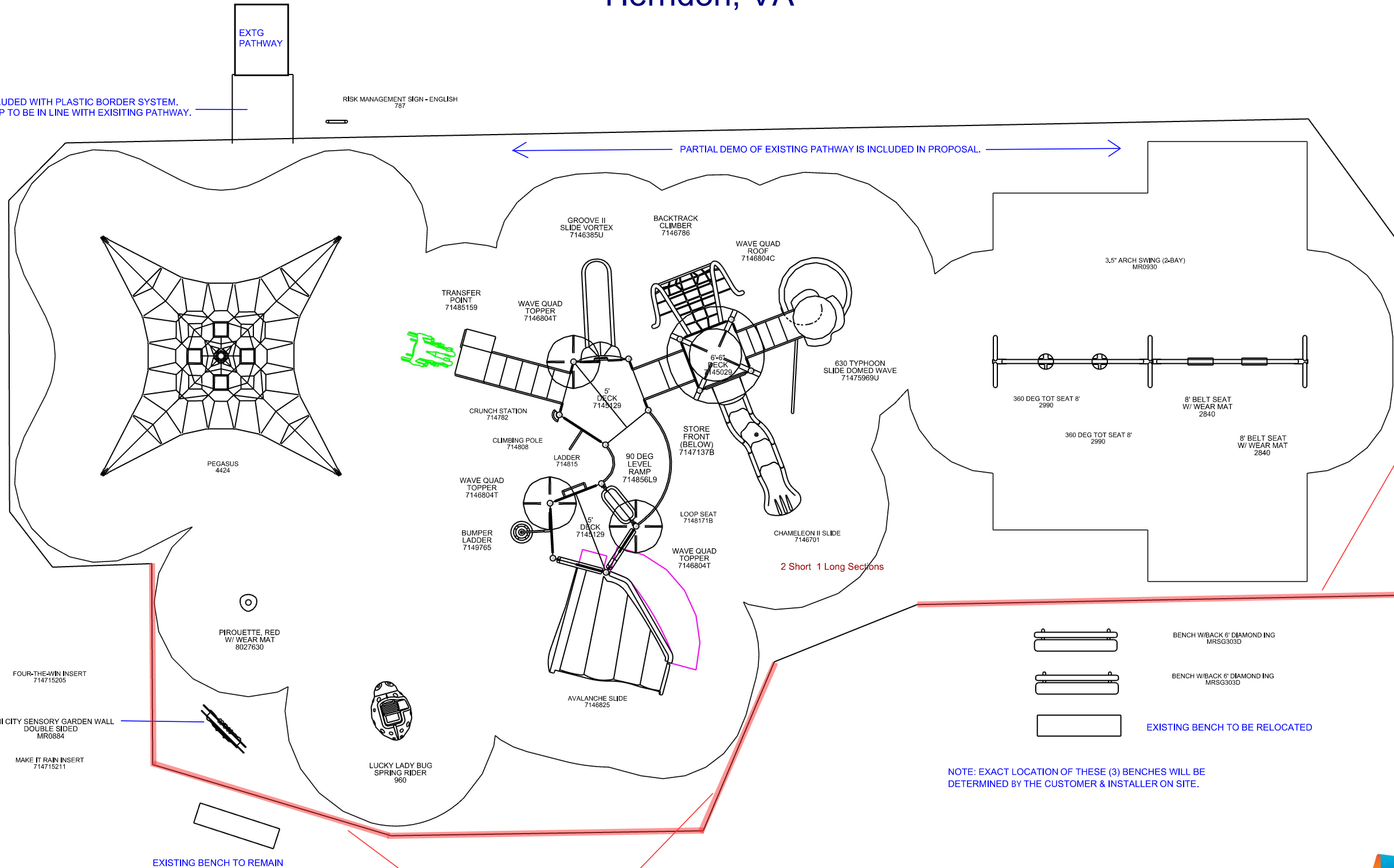

WHEN POSSIBLE, NEW PLASTIC PERIMETER BORDERS ARE TO FOLLOW THE EXISTING PLAYGROUND FOOTPRINT.

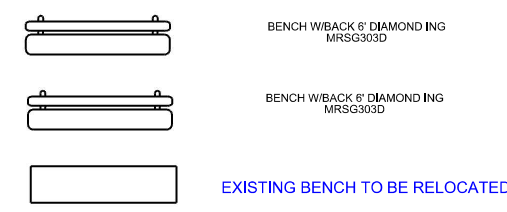

NOTE: EXACT LOCATION OF THESE (3) BENCHES WILL BE DETERMINED BY THE CUSTOMER & INSTALLER ON SITE.

WHEN POSSIBLE, NEW PLASTIC PERIMETER BORDERS ARE TO FOLLOW THE EXISTING PLAYGROUND FOOTPRINT.



<b>SITE CONCEPTS</b>	
SALES & ACCOUNTING OFFICE 5320 WHITE OAK ROAD No. PURLEAR, NC	FAX NO: Enter Fax numbe
GROUND SPACE: 88' x 46'-6"	
PROTECTIVE AREA: 101'-6" x 52'-6"	
DRAWN BY: George Novey	DATE: 11/12/2025

<b>25014527</b>	
✓	COMPLIES TO ASTM/CPSC
✓	COMPLIES TO ADA

To promote safe and proper equipment use by children. Miracle recommends the installation of either a Miracle safety sign or other appropriate safety signage near each playsystem's main entry point(s) to inform parents and supervisors of the age appropriateness of the playsystem and general rules for safe play.

THE PLAY COMPONENTS IDENTIFIED IN THIS PLAN ARE IPEMA CERTIFIED. THE USE AND LAYOUT OF THESE COMPONENTS CONFORM TO THE REQUIREMENTS OF ASTM F1487.

AN ENERGY ABSORBING PROTECTIVE SURFACE IS REQUIRED UNDER & AROUND ALL PLAY SYSTEMS

Page 11 of 137

**Arch Swing Frames 3.5"** (inground and bolt down)

2 Seat, 2 Seat Add-A-Bay, 1 Seat, 1 Seat Add-A-Bay

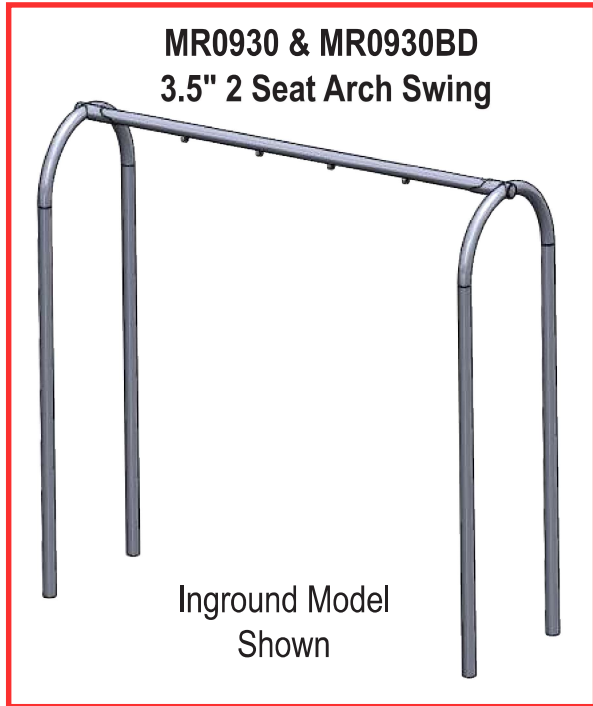

Arch Swing Frames 3.5" & Add-A-Bays 3.5"  
MR0930, MR0930BD, MR0932, MR0932BD, MR0934, MR0934BD, MR0936, MR0936BD

## Arch Swing Frames 3.5" (inground and bolt down)

2 Seat, 2 Seat Add-A-Bay, 1 Seat, 1 Seat Add-A-Bay

Model #	Product	Protective Area	Concrete
MR0930	3.5" 2 Seat Arch Swing	24' x 32'	0.5 cu.yds.
MR0930BD	3.5" 2 Seat Arch Swing - BD	24' x 32'	0.5 cu.yds.
MR0932	3.5" 2 Seat Arch Swing Add-A-Bay	24' x 32'	0.5 cu.yds.
MR0932BD	3.5" 2 Seat Arch Swing Add-A-Bay - BD	24' x 32'	0.5 cu.yds.
MR0934	3.5" 1 Seat Arch Swing	21' x 32'	0.25 cu.yds.
MR0934BD	3.5" 1 Seat Arch Swing - BD	21' x 32'	0.25 cu.yds.
MR0936	3.5" 1 Seat Arch Swing Add-A-Bay	21' x 32'	0.25 cu.yds.
MR0936BD	3.5" 1 Seat Arch Swing Add-A-Bay - BD	21' x 32'	0.25 cu.yds.

### DESCRIPTION

All models consist of arch weldments and header weldments which assemble to form a swing frame. Swings must be ordered separately.

### MATERIALS

Arches:	Arch weldments shall consist of the arch and stub(s). Arches shall be constructed of 3-1/2" tube, 11-gauge. Stubs shall be constructed of 4" tube, 7-gauge. The stub(s) shall be solid <u>welded</u> to the arches.
Header:	The header weldment shall consist of the header and bushing housings. The header shall be constructed of 3-1/2" tube, 8-gauge. The header shall have bushing housings <u>welded</u> to it with oil-impregnated bushings installed after painting.
Clevises:	The clevises shall be cast of ductile iron grade 60-40-18.
Fasteners:	All fastening hardware shall be <u>Fastener Style A</u> .
Finishes:	The arches and header shall be finished in <u>Mira-Cote</u> . The clevises shall be zinc plated.

*Consult Miracle's "Glossary of Technical Data for Materials, Processes & Finishes" for specifications of underlined items.*

## Swing Seats

284, 2840 and 2841  
Slashproof Seat



299 and 2990  
360° Tot Seat

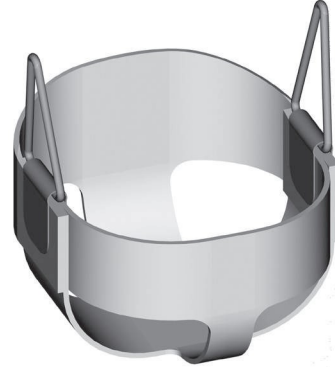

*Note: Chains NOT shown.*

2740 and 2741  
Inclusive Swing Seat

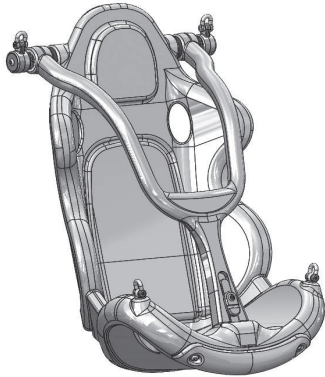

2760  
Generation Swing Seat



*Note: Chains NOT shown.*

Swing Seats

284, 2840, 2841, 299, 2990, 2740, 2741, 2760

## Swing Seats

### DESCRIPTION:

The Slashproof Seat is a flexible flat single strap seat with end attachment points and has an exterior surface of EPDM rubber. The 360 Degree Slashproof Tot Seat is a flexible seat fabricated into a configuration of a wide strap through the bottom, a wide strap running completely around at the top, and two (2) interconnecting straps at the front and the rear of the seat for complete enclosure of the small user. The exterior surface is EPDM rubber. The Inclusive Swing Seats are Rockite seats molded to form a chair. Models with chain each have two chains to suspend the swing from a swing frame header. The Generation Swings are Rockite seats molded to form a double sided swing, one side a tot swing design and the other for an adult. Models with chain each have two chains to suspend the swing from a swing frame header.

### MATERIALS:

#### Slashproof Seat:

The Slashproof Seat is constructed of a 4" wide inner steel insert of type 301 stainless spring steel, 0.020" thick. The slashproof seat is 26" long (excluding mounting triangles) x 5" wide x 5/8" thick at the front and rear leading cushion edges. The rubber molded to the steel core is 70 durometer EPDM. At each end a 16 ga. galvanized steel clip 3" wide is attached by three stainless steel rivets through the clip and seat subassembly. A 3/8" diameter galvanized steel mounting triangle is encompassed by the steel clip at each end of the seat.

#### 360 Degree Tot Seat:

The 360 Degree Tot Seat is constructed of a one piece die cut 0.020" thick, martensitic spring steel insert with 70 durometer EPDM rubber, 1/4" thick, molded to the insert. The main seat strap is 5" wide, the back strap is 4" wide, and the front strap is 2" wide. The two (2) places where the straps are interconnected and form the suspension points for the seat are held by a clip and grommet system. The clip is 4" wide 16 ga. galvanized steel. There are two grommets per clip, each of which is 3/4" O.D. by 14 ga. wall galvanized steel tubing, flared to securely attach the clip to the seat. The two (2) mounting triangles are secured to the seat by clips and are made from 3/8" steel round stock, formed and galvanized.

#### Inclusive Swing Seat:

The Inclusive Swing Seat shall be constructed of Rockite. Attached to the seat is a reinforced polyurethane rubber bumper. The sliding latch mechanism is constructed from 6061 machined aluminum.

#### Generation Swing Seat:

The Generation Swing shall be constructed of Rockite.

#### Chain:

Each chain assembly is 4/0 straight link coil chain.

#### "D" Shackle:

The "D" Shackle for all models except the Inclusive Swing Seat and Generation Swing Seat are sand cast of ductile iron grade 60-40-18.

#### Finishes:

All rubber surfaces are EPDM. The Rockite Inclusive Swing Seat have molded-in color. All exposed metal surfaces are bright zinc plated. The clevises are zinc plated.

Kids' Choice® - Mira-Therm II

## Decks

Deck Posts not included in these assemblies.

### 714-501-9

#### Triangle Deck

Model # 714-501-9 requires three (3) Posts.

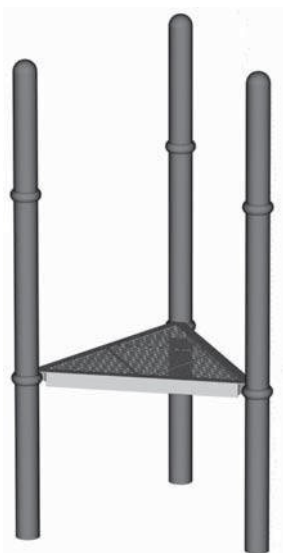

### 714-502-9

#### Square Deck

Model # 714-502-9 requires four (4) Posts.

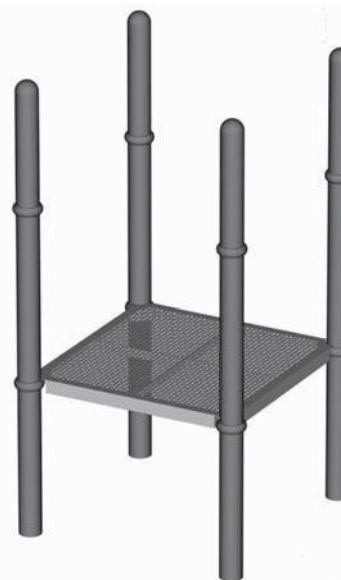

### 714-503-9

#### Half Hex Deck (Full)

Model # 714-503-9 requires four (4) Posts.



### 714-504-9

#### Half Hex Deck

Model # 714-504-9 requires five (5) Posts.



Kids' Choice® - Mira-Therm II  
**Decks**

**714-508-9**

**Rectangle Deck (Full)**

*Model # 714-508-9 requires four (4) Posts.*



**714-509-9**

**Rectangle Deck (Half Open)**

*Model # 714-509-9 requires five (5) Posts.*



**714-510-9**

**Rectangle Deck (Open)**

*Model # 714-510-9 requires six (6) Posts.*



Kids' Choice® - Mira-Therm II  
**Decks**

**714-512-9**

**Pentagon Deck**

*Model # 714-512-9 requires five (5) Posts.*



**714-517-9**

**Heptagon Deck**

*Model # 714-517-9 requires seven (7) Posts  
and one (1) middle support post.*

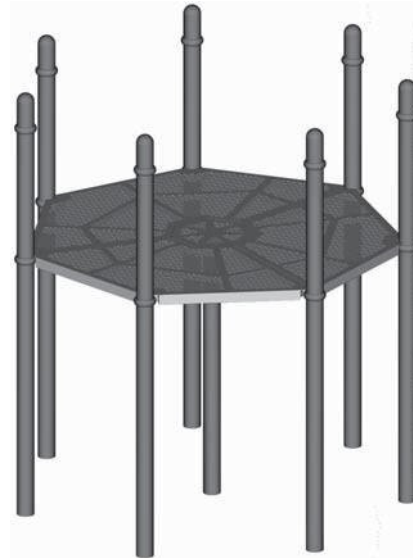

*THIS SPACE INTENTIONALLY LEFT BLANK*

Kids' Choice® - Mira-Therm II  
**Decks**

<u>MODEL #</u>	<u>PRODUCT</u>	<u>POSTS REQ'D</u>	<u>DECK SURFACE</u>	<u>CONCRETE</u>
714-501-9	Triangle Deck	3	7 sq. ft.	See Post specs
714-502-9	Square Deck	4	16 sq. ft.	"
714-503-9	Half Hex Deck (Full)	4	21 sq. ft.	"
714-504-9	Half Hex Deck (Open)	5	21 sq. ft.	"
714-508-9	Rectangle Deck (Full)	4	32 sq. ft.	"
714-509-9	Rectangle Deck (Half Open)	5	32 sq. ft.	"
714-510-9	Rectangle Deck (Open)	6	32 sq. ft.	"
714-512-9	Pentagon Deck	5	26.5 sq. ft.	"
714-517-9	Heptagon Deck	7	55 sq. ft.	"

**DESCRIPTION**

Mira-Therm II deck models include an equilateral triangle deck, a square deck, two half hexagon decks, three rectangular decks, a pentagon deck, and a heptagon deck. Decks are designed for maximum flexibility in height of deck surface, from 0" to 6'-6" (in 6" increments), though 3', 5', and 6'-6" are considered standard deck heights.

Decks are designed on a 48" center-to-center spacing on 5" deck posts, at equal or varied heights. All deck-to-post connections are made with a deck support clamp. All deck connections are made beneath deck with no exposed fasteners on deck perimeter. Decks with 8' wide open side are designed to attach to another deck with 8' wide open side at same deck height.

**MATERIALS**

**Decks:** All decks shall be constructed with folded 11 ga. steel sheet forming 3" tall sides. Decking sheets shall be perforated with a staggered pattern of 3/8" diameter holes at 5/8" apart center-to-center. The decking shall have 7 ga. by 2" flat steel braces and corner braces of 7 ga. steel. The entire assembly shall be solid welded prior to PVC coating.

**Fasteners:** Deck assemblies shall contain Versalok Fasteners and Fastener Style A hardware.

**Finishes:** All deck surfaces shall be coated in Mira-Therm. Clamps shall have a Mira-Cote finish.

Consult Miracle's "Glossary of Technical Data for Materials, Processes & Finishes" for specifications of underlined items.



## Kids' Choice® Chameleon II Slide System

### Chameleon II Slide (Sample)

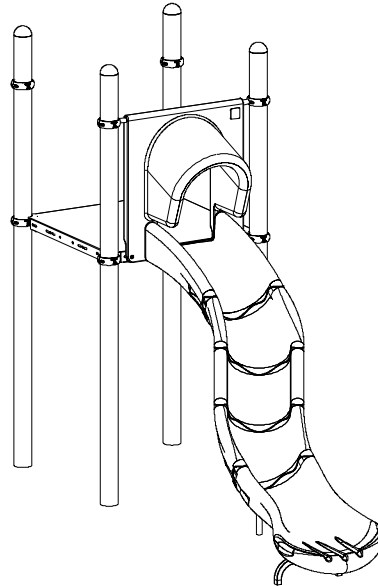

Chameleon Slide System

**714-670,  
714-670-1,  
714-670-2,  
714-670-4,  
714-670-5,  
714-670-6,  
714-670-7**

*All Chameleon Slide systems contain one Model # 714-670 and up to seven additional pieces (determined by deck height) in any combination of remaining models (-5, -6, -7).*

#### SECTIONAL SLIDE COMPONENTS

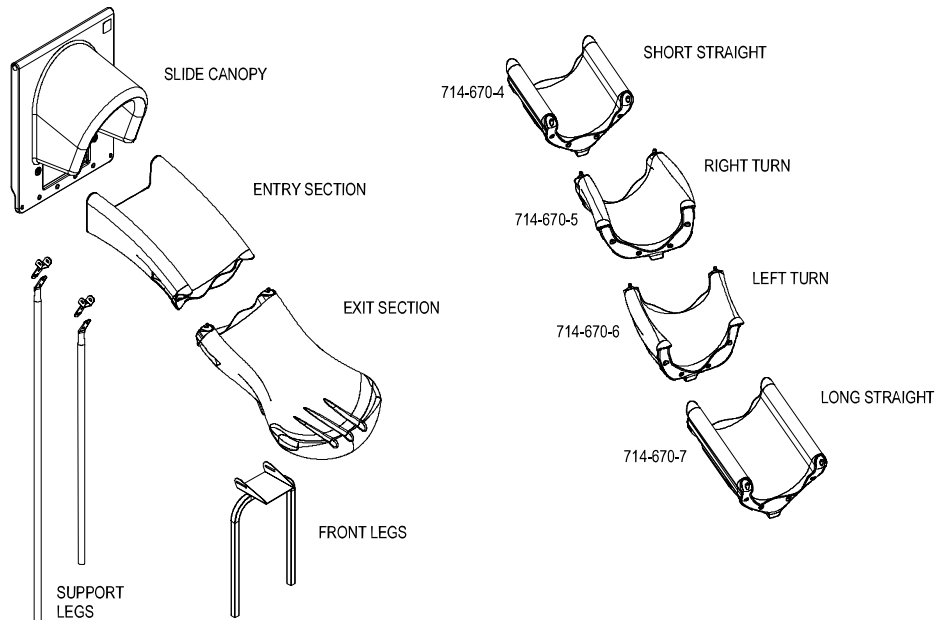

714-670: 30" TO 54" DECK HT; NO SUPPORT LEGS  
714-670-1: 60" TO 78" DECK HT; ONE SHORT SUPPORT LEG  
714-670-2: 84" TO 102" DECK HT; TWO SUPPORT LEGS

714-670, 714-670-1, 714-670-2, 714-670-4, 714-670-5, 714-670-6, 714-670-7

Kids' Choice®  
**Chameleon II Slide System**

<u>MODEL #</u>	<u>PRODUCT</u>
714-670	Chameleon II Entry & Exit 2'-6" - 4'-6"
714-670-1	Chameleon II Entry & Exit 5' - 6'-6"
714-670-2	Chameleon II Entry & Exit 7' - 8'-6"
714-670-4	Chameleon II Short Straight Section
714-670-5	Chameleon II Right Section
714-670-6	Chameleon II Left Section
714-670-7	Chameleon II Long Straight Section

*Note: Ground space and protective area required are dependent upon the specific configuration. Footings for the assembly require 0.05 cu. yds. of concrete for models attached to decks 3', 0.10 cu. yds. of concrete for models attached to decks 5' and 4', 0.15 cu. yds. of concrete for models attached to decks 6', 6'-6" and 8'.*

**DESCRIPTION**

The Chameleon Slide System features interchangeable bedway sections to present maximum versatility in design configuration. The componentized, open bedway slide assembly may be attached to 2'-6" - 8'-6" decks.

**MATERIALS**

- Slide Assembly:** The bedway sections, entry panel and exit section shall be constructed of double wall Rockite with a 18" bedway and 13-3/4" high sidewalls. The entry panel shall be supported by a rung of 1" pipe.
- Front Leg:** The front leg shall be constructed of 1.5" X 16 ga. square tube and a bracket of 7 ga. galvanized sheet steel.
- Support Legs:** Support legs shall be constructed of 1.66 OD x 13 ga. tube and a mounting bracket of 7 ga. sheet, solid welded.
- Leg Bracket:** Shall be constructed of 7 ga. galvanized sheet steel, solid welded.
- Fasteners:** The assembly shall contain Versalok Fasteners and Fastener Style A hardware.
- Finishes:** The rung, front leg, support legs and leg brackets shall have a Mira-Cote finish. The Rockite slide sections shall have color molded in.

Consult Miracle's "Glossary of Technical Data for Materials, Processes & Finishes" for specifications of underlined items.

Kids' Choice®

**Imagination Panels & Activity Panels - Below Deck**

Models included:

<u>MODEL</u>	<u>DESCRIPTION</u>
714-602-6B	Steel Panel, Crawl Through
714-617-B	Space Ship Panel
714-713-5B	Door Panel
714-713-17B	Door Panel Below Deck
714-713-18B	Window Panel Below Deck
714-713-19B	Store Panel Below Deck
714-713-20B	Door Panel W/Welcome Below Deck
714-713-21B	Space Maze Panel KC Below Deck
714-713-22B	Alphabet Panel KC Below Deck
714-713-23B	Braille Panel KC Below Deck
714-713-24B	Sign Language Phrases Panel KC Below Deck
714-713-25B	Sign Language Alphabet Panel KC Below Deck
714-714-2B	Fire Truck Panel
714-714-4B	Train Panel
714-714-11B	4 X 4 Panel KC Below Deck
714-714-11HB	4 X 4 Half Panel KC Below Deck
714-714-12B	Big Rig Panel Below Deck
714-714-13B	Plane Panel KC Below Deck
714-715-3B	3' Jump Panel
714-715-5B	5' Jump Panel
714-715-13B	Calypso 3-Drum Panel
714-715-20B	Activity Panel Frame

**MODELS CONTINUED ON NEXT PAGE**

Consult Miracle's "Glossary of Technical Data for Materials, Processes & Finishes" for specifications of underlined items.

**Imagination & Activity Panels (Below Deck)**

714-602-6B, 714-617-B, 714-713-5B, 714-714-2B, 714-714-4B,, 714-715-13B, 714-715-20B, 714-761-2B, 714-761-3B, 714-761-4B, 714-713-17B, 714-713-18B, 714-713-19B, 714-713-20B, 714-714-11B, 714-714-11HB, 714-714-12B, 714-714-13B, 714-715-25B, 714-715-26B, 714-715-27B, 714-715-28B, 714-715-29B, 714-715-3B, 714-715-5B, 714-895-1B, 714-895-2B, 714-895-3B, 714-713-21B, 714-713-22B, 714-713-23B, 714-713-24B, 714-713-25B

**Imagination & Activity Panels (Below Deck)**

Kids' Choice®

**Imagination Panels & Activity Panels - Below Deck**

Models included: (continued):

<u>MODEL</u>	<u>DESCRIPTION</u>
714-715-25B	Museum Mosaic Disk Panel KC Below Deck
714-715-26B	Museum Opt Illusion Panel KC Below Deck
714-715-27B	Museum Pin Panel KC Below Deck
714-715-28B	Museum Washer Panel KC Below Deck
714-715-29B	Museum Zoetrope KC Below Deck
714-761-2B	Piston Panel
714-761-3B	Gear Panel
714-761-4B	Sliding Tile Panel
714-895-1B	Barn Wall Panel
714-895-2B	Barn Door Panel
714-895-3B	Barn Window Panel

*Note:*

*Deck systems are NOT included in these assemblies. Please refer to Construction Drawings for the model particular to your system.*

714-602-6B, 714-617-B, 714-713-5B, 714-713-17B, 714-713-18B, 714-713-19B, 714-713-20B, 714-714-4B, 714-714-11B, 714-714-11HB, 714-714-12B, 714-714-13B, 714-715-25B, 714-715-26B, 714-715-27B, 714-715-28B, 714-715-29B, 714-715-5B, 714-895-1B, 714-895-2B, 714-895-3B, 714-713-21B, 714-713-22B, 714-713-23B, 714-713-24B, 714-713-25B

**714-602-6B:  
Steel Panel, Crawl Through**

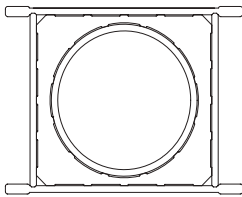

**714-617-B:  
Space Ship Panel**

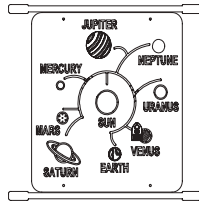

**714-713-5B:  
Door Panel**

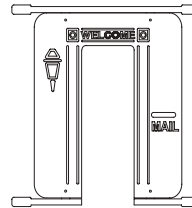

**714-713-17B  
Door Panel  
Below Deck**

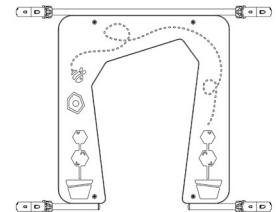

**714-713-18B  
Window Panel  
Below Deck**

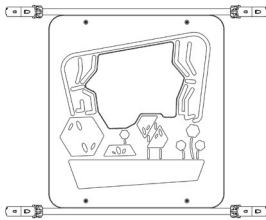

**714-713-19B  
Store Panel  
Below Deck**

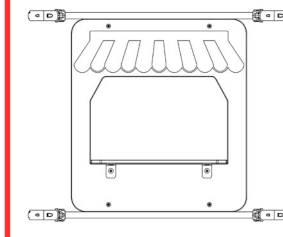

**714-713-20B  
Door Panel W/Welcome  
Below Deck**

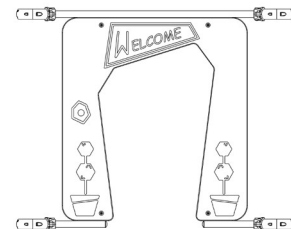

Kids' Choice®

# Imagination Panels & Activity Panels - Below Deck

**714-713-21B:**  
Space Maze Panel KC  
Below Deck

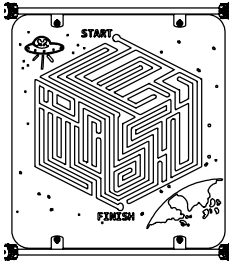

**714-713-22B:**  
Alphabet Panel KC  
Below Deck

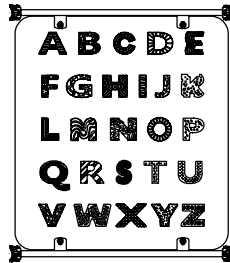

**714-713-23B:**  
Braille Panel KC  
Below Deck

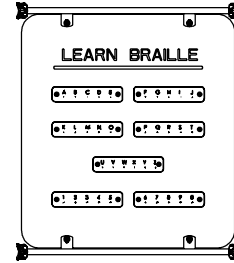

**714-713-24B:**  
Sign Language Phrases  
Panel KC Below Deck

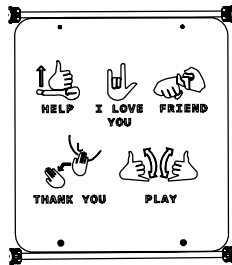

**714-714-25B:**  
Sign Language Alphabet  
Panel KC Below Deck

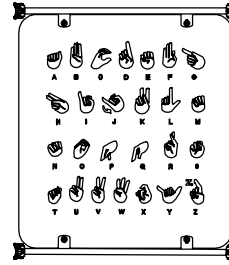

**714-714-2B:**  
Fire Truck Panel

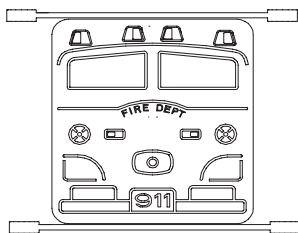

**714-714-4B:**  
Train Panel

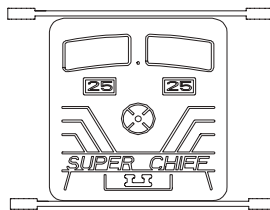

**714-714-11B**  
4 X 4 Panel KC  
Below Deck

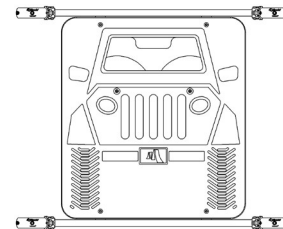

Imagination & Activity Panels (Below Deck)

714-602-6B, 714-617-B, 714-713-5B, 714-714-2B, 714-714-4B, 714-715-13B, 714-715-20B, 714-761-2B, 714-761-3B, 714-761-4B, 714-713-17B, 714-713-18B, 714-713-19B, 714-713-20B, 714-714-11B, 714-714-11HB, 714-714-12B, 714-714-13B, 714-715-25B, 714-715-26B, 714-715-27B, 714-715-28B, 714-715-29B, 714-715-3B, 714-715-5B, 714-895-1B, 714-895-2B, 714-895-3B, 714-713-21B, 714-713-22B, 714-713-23B, 714-713-24B, 714-713-25B

Imagination & Activity Panels (Below Deck)

Kids' Choice®

Imagination Panels & Activity Panels - Below Deck

714-714-11HB  
4 X 4 Half Panel KC  
Below Deck

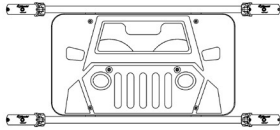

714-714-12B  
Big Rig Panel  
Below Deck

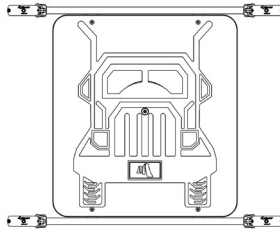

714-714-13B  
Plane Panel KC  
Below Deck

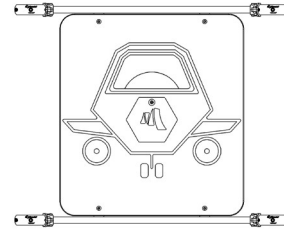

714-715-3B:  
Jump Panel  
(3' Deck)

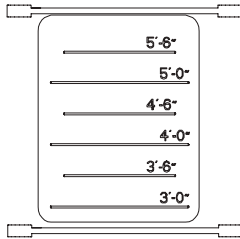

714-715-5B:  
Jump Panel  
(5' Deck)

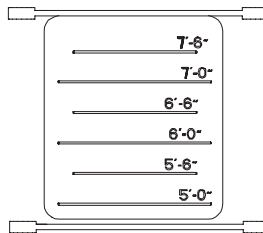

714-715-13B:  
Calypso 3-Drum Panel

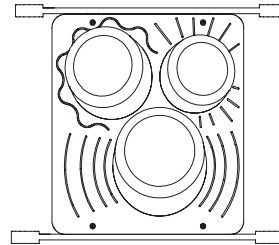

714-715-20B:  
Activity Panel Frame

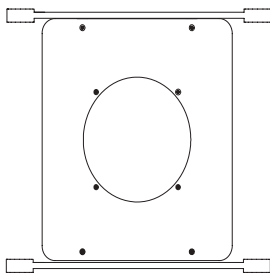

714-715-25B  
Museum Mosaic Disk  
Panel KC Below Deck

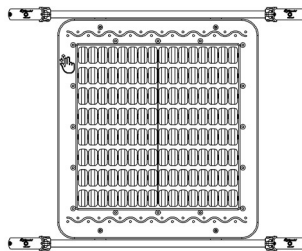

714-715-26B  
Museum Opt Illusion Panel  
KC Below Deck

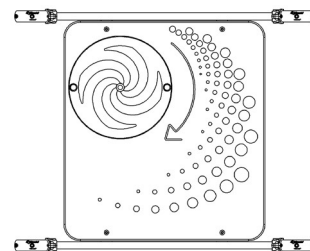

714-715-27B  
Museum Pin Panel  
KC Below Deck

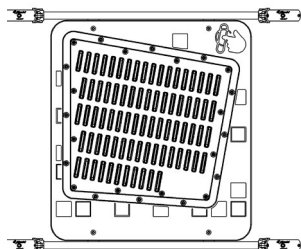

714-715-28B  
Museum Washer Panel KC  
Below Deck

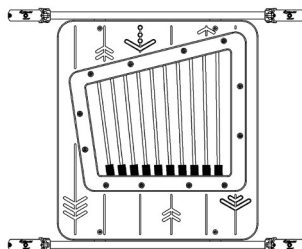

714-715-29B  
Museum Zoetrope  
KC Below Deck

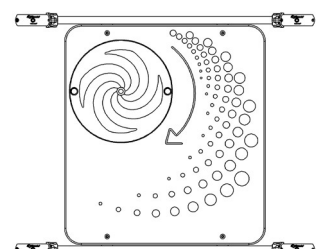

714-602-6B, 714-617-B, 714-713-5B, 714-714-2B, 714-714-4B,, 714-715-13B, 714-715-20B, 714-761-2B, 714-761-3B, 714-761-4B,  
714-713-17B, 714-713-18B, 714-713-19B, 714-713-20B, 714-714-11B, 714-714-11HB, 714-714-12B, 714-714-13B, 714-715-25B,  
714-715-26B, 714-715-27B, 714-715-28B, 714-715-29B, 714-715-5B, 714-895-1B, 714-895-2B, 714-895-3B, 714-713-21B,  
714-713-22B, 714-713-23B, 714-713-24B, 714-713-25B

Kids' Choice®

# Imagination Panels & Activity Panels - Below Deck

**714-761-2B:  
Piston Panel**

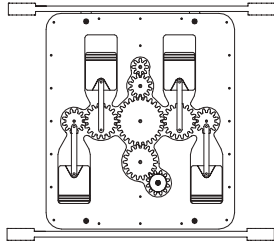

**714-761-3B:  
Gear Panel**

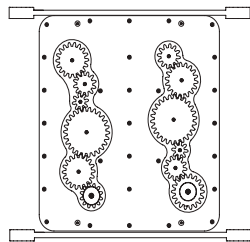

**714-761-4B:  
Sliding Tile Panel**

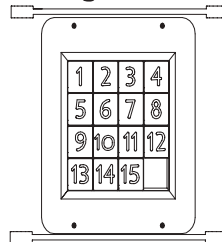

**714-895-1B:  
Barn Wall Panel**

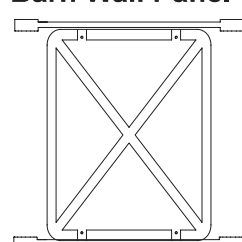

**714-895-2B:  
Barn Door Panel**

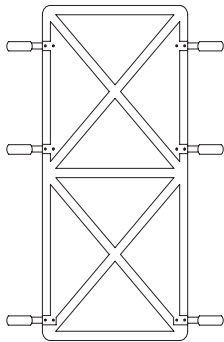

**714-895-3B:  
Barn Window Panel**

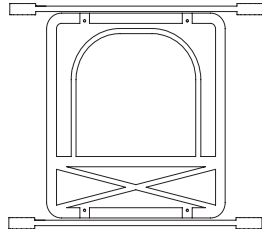

**Imagination & Activity Panels (Below Deck)**

714-602-6B, 714-617-B, 714-713-5B, 714-714-2B, 714-714-4B,, 714-715-20B, 714-761-2B, 714-761-3B, 714-761-4B,  
714-713-17B, 714-713-18B, 714-713-19B, 714-713-20B, 714-714-11B, 714-714-11HB, 714-714-12B, 714-714-13B, 714-715-25B,  
714-715-26B, 714-715-27B, 714-715-28B, 714-715-29B, 714-715-3B, 714-715-5B, 714-895-1B, 714-895-2B, 714-895-3B, 714-713-21B,  
714-713-22B, 714-713-23B, 714-713-24B, 714-713-25B

Kids' Choice®

## Imagination Panels & Activity Panels - Below Deck

### DESCRIPTION

These representational activity panels, designed to enhance imagination and creative play, may be freestanding, clustered or below deck.

- Vehicle-themed panels feature steering wheel assemblies.
- The Piston Panel and Gear Panel contain dynamic, user-driven parts sealed behind a transparent, tamper-resistant cover.
- The Sliding Tile Panel contains 15 routed, moveable tiles with one empty space challenging users to shift the tiles into proper sequence.
- The Calypso 3-Drum Panel allows musical expression, that may be struck with the hands to create different sounds.

### MATERIALS

**Panels:** The panels shall be constructed of Mira-Lene with all corners rounded. Panels shall measure 36-1/2" x 40" and shall contain routed designs in several themes. The panel shall be supported between posts by top and bottom rungs of 1" pipe, each with two tabs of 11 ga. A-60 Galvannealed sheet, solid welded.

**Steel Panel, Crawl Through** Model 714-602-6B only  
The steel crawl through panel shall comprise rungs and a ring of 1" pipe, Gator Grip, and a 7 ga. sheet, laser cut panel measuring 33-5/8" x 36".

**Barn Door Panel:** Model 714-895-2B only  
In addition to the above materials and specifications, Model 714-895-2B shall be supported between posts by top, middle and bottom rungs of 1" pipe, each with two (2) tabs of 11 ga. A-60 Galvannealed sheet, solid welded. Panel shall measure 36-1/2" x 71-1/2".

**Gear Panel and Piston Panel:** Model 714-761-3B, 714-761-2B only  
In addition to the above materials and specifications, Model 714-761-3B shall contain a clear polycarbonate cover mechanically fastened over two side-by-side sets of 1/4" thick gears, to be constructed of high-density polyethylene, which shall turn on nylon bushings, except for black nylon handles and drive gears which shall turn on bronze bushings. Its opposite side shall contain side-by-side routed finger mazes. Model 714-761-2B shall contain a cover, gears, and knob as described herein, and connecting rod and piston shapes of 1/4" thick high-density polyethylene as well. Its opposite side shall contain routed designs.

**Sliding Tile Panel:** Model 714-761-4B only  
In addition to material and specifications detailed in "panels" paragraph above, Model 714-761-4B shall contain 15 moveable, tongue-and-groove tiles with routed numerals constructed of 1/4" thick high-density polyethylene.

**Store Panel:** Model 714-713-19B only  
In addition to material and specifications detailed in "panels" paragraph above, Model 714-713-19B shall contain brackets holding the counter panel on constructed of 7ga. glv bent sheet steel.

**Braille Panel KC:** 714-713-23B only  
In addition to material and specifications detailed in "panels" paragraph above, model 714-713-23B shall contain 3/32" lexan.

Consult Miracle's "Glossary of Technical Data for Materials, Processes & Finishes" for specifications of underlined items.

714-602-6B, 714-617-B, 714-713-5B, 714-714-2B, 714-714-4B,, 714-715-13B, 714-715-20B, 714-761-2B, 714-761-3B, 714-761-4B, 714-713-17B, 714-713-18B, 714-713-19B, 714-713-20B, 714-714-11B, 714-714-11HB, 714-714-12B, 714-714-13B, 714-715-25B, 714-715-26B, 714-715-27B, 714-715-28B, 714-715-29B, 714-715-5B, 714-895-1B, 714-895-2B, 714-895-3B, 714-713-21B, 714-713-22B, 714-713-23B, 714-713-24B, 714-713-25B



Kids' Choice®

## Imagination Panels & Activity Panels - Below Deck

### **MATERIALS** *(continued)*

**Calypso 3-Drum Panel:**  
Model 714-715-13B only

In addition to material and specifications detailed in "panels" paragraph above, Model 714-715-13B shall contain 3 rotational molded drums of low density polyethylene resin. Each drum is attached to the panel through a cover plate constructed of 11 ga. galvanized steel sheet with a Mira-Cote finish.

**Museum Pin Panel**  
**KC: 714-715-27B only**

In addition to material and specifications detailed in "panels" paragraph above, model 714-715-27B shall contain polystyrene high impact static cylinders in red and blue and ½" stainless steel rods.

**Museum Washer**  
**Panel KC: 714-715-28B only**

In addition to material and specifications detailed in "panels" paragraph above, model 714-715-28B shall contain ½" stainless steel acme threaded rod.

**Museum Zoetrope**  
**KC: 714-715-29B only**

In addition to material and specifications detailed in "panels" paragraph above, model 714-715-29B shall contain the weldment for the spinner event which shall be constructed of SHST HR 4.5mm (7 ga.) and 1215 steel.

**Rung Bracket:**

The rung brackets shall be constructed of 1" pipe with bolting tabs of 11 ga. A-60 Galvanized sheet, all solid welded.

**Steering Wheel:**

The steering wheel on vehicle-themed panels shall be constructed of a high density polyethylene produced from high performance, U.V. stabilized rotational molding grade resins with a comprehensive additive package. These resins are tested in accordance with ASTM testing procedures D-1505, D-1248, D-1693 (b), D-638, D-790 and D-746. Resin's properties shall exhibit a balance of toughness, rigidity, environmental stress crack resistance and excellent low temperature impact performance. Wall thickness shall be 1/8". The steering wheel hub cover shall be constructed of injection molded polypropylene which shall contain U.V. light stabilizers. Model 714-714-11B 4X4 Panel shall contain two side-by-side steering wheels for cooperative play.

**Star Brackets:**

Themed for Space Ship Panel, star brackets shall be constructed of 11 ga. HRPO steel and powder coat painted.

**Fasteners:**

Each assembly shall contain Versalok Fasteners and Fastener Style A hardware.

**Finishes:**

The steering wheel and two-color panels shall have molded-in color. The rungs, clamps, and steel panel shall have a Mira-Cote finish.

Consult Miracle's "Glossary of Technical Data for Materials, Processes & Finishes" for specifications of underlined items.

**Imagination & Activity Panels (Below Deck)**

714-602-6B, 714-617-B, 714-713-5B, 714-714-2B, 714-714-4B,, 714-715-13B, 714-715-20B, 714-761-2B, 714-761-3B, 714-761-4B, 714-713-17B, 714-713-18B, 714-713-19B, 714-713-20B, 714-713-20B, 714-714-11B, 714-714-11HB, 714-714-12B, 714-714-13B, 714-715-25B, 714-715-26B, 714-715-27B, 714-715-28B, 714-715-29B, 714-715-3B, 714-715-5B, 714-895-1B, 714-895-2B, 714-895-3B, 714-713-21B, 714-713-22B, 714-713-23B, 714-713-24B, 714-713-25B

Kids' Choice®

**Vertical Climbers** Trap Door Climber, Climbing Pole, Spider Climber, Spiral Climber, Wiggly Worm Climber & Bumper Ladder

## 714-731\* & 714-731-6

### Trap Door Climber for 6'-6" Deck

\* Model # 714-731 Trap Door Climber for 3' or 5' Deck not shown.

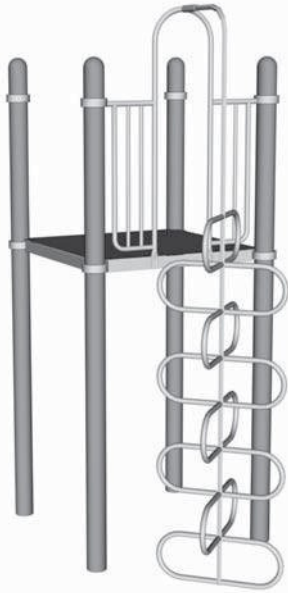

## 714-808 & 714-808-8\*

### Climbing Pole for 3', 5' or 6'-6" Deck

\* Model # 714-808-8 Climbing Pole for 8' Deck not shown.



## 714-908

### Spider Climber for 3', 5' or 6'-6" Deck



## 714-969 & 714-969-5

### Spiral Climber for 6'-6" Deck

\* Model # 714-969-5 Spiral Climber for 3' or 5' Deck not shown.

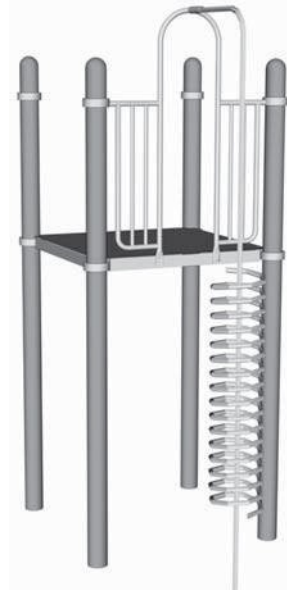

Vertical Climbers

714-731, 714-731-6, 714-808, 714-808-8, 714-908, 714-969, 714-969-5, 714-974-6, 714-974-8, 714-974-8, 714-976-3, 714-976-5, 714-976-6

Kids' Choice®  
**Vertical Climbers**

**714-974-6\* & 714-974-8**

**Wiggly Worm Climber for 8' Deck**

\*Model # 714-974-6 Wiggly Worm Climber for 5' & 6'-6" Deck not shown.



**714-976-3 & 714-976-5\***

**Bumper Ladder for 3' Deck**

\* Model # 714-976-5 Bumper Ladder for 5' Deck and Model # 714-976-6 Bumper Ladder for 6'-6" Deck not shown.

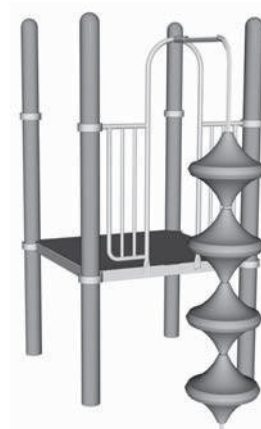

Vertical Climbers

714-731, 714-731-6, 714-808, 714-808-8, 714-908, 714-969, 714-969-5, 714-974-6, 714-974-8, 714-976-3, 714-976-5, 714-976-6

**Kids' Choice®  
Vertical Climbers**

<u>MODEL #</u>	<u>PRODUCT</u>	<u>GRND SPC</u>	<u>PROT. AREA</u>	<u>CONCRETE</u>
714-731	Trap Door Climber, 3' or 5' Deck	3'-0" x 3'-0"	9'-0" x 15'-0"	0.05 cu. yds.
714-731-6	Trap Door Climber, 6'-6" Deck	3'-0" x 3'-0"	9'-0" x 15'-0"	0.05 cu. yds.
714-808	Climbing Pole, 3', 5' or 6'-6" Deck	3'-0" x 3'-0"	9'-0" x 15'-0"	0.05 cu. yds.
714-808-8	Climbing Pole, 8' Deck	3'-0" x 3'-0"	9'-0" x 15'-0"	0.05 cu. yds.
714-908	Spider Climber, 3', 5' or 6'-6" Deck	3'-0" x 3'-0"	9'-0" x 15'-0"	0.05 cu. yds.
714-969	Spiral Climber, 6'-6" Deck	3'-0" x 3'-0"	9'-0" x 15'-0"	0.05 cu. yds.
714-969-5	Spiral Climber, 5' Deck	3'-0" x 3'-0"	9'-0" x 15'-0"	0.05 cu. yds.
714-974-6	Wiggly Worm Climber, 5' or 6'-6" Deck	3'-0" x 3'-9"	9'-0" x 15'-9"	0.05 cu. yds.
714-974-8	Wiggly Worm Climber, 8' Deck	3'-0" x 3'-9"	9'-0" x 15'-9"	0.05 cu. yds.
714-976-3	Bumper Ladder, 3' Deck	3'-0" x 3'-0"	9'-0" x 15'-0"	0.05 cu. yds.
714-976-5	Bumper Ladder, 5' Deck	3'-0" x 3'-0"	9'-0" x 15'-0"	0.05 cu. yds.
714-976-6	Bumper Ladder, 6'-6" Deck	3'-0" x 3'-0"	9'-0" x 15'-0"	0.05 cu. yds.

**DESCRIPTION**

These challenging vertical climbers are used for access to and egress from deck systems of various heights. The assemblies contain arched enclosures for field assembly to decks.

**MATERIALS**

**Trap Door Climber:** The pole shall be die-formed 1-1/4" pipe. The pole extension and "U" shaped rungs shall be die-formed 1" pipe. The assembly shall be solid welded.

**Climbing Pole:** The climbing pole shall be constructed of 1" pipe, 12 ga.

**Spider Climber:** The pole and "U" shaped rungs shall be die-formed 1" pipe. The spider climber shall be a welded assembly.

**Spiral Climber:** The spiral climber and extension tube shall be entirely constructed of 1" pipe, formed, drilled and all solid welded construction with plastic pipe plugs inserted in open ends.

**Wiggly Worm Climber:** The assembly shall comprise loops solid welded to frames, all of 1-1/4" pipe, 10 ga.

**Bumper Ladder:** The "top" shaped bumper shall be constructed of Rockite supported internally by a pole constructed of 1" pipe, 10 ga. Each bumper shall measure 18" high x 19" wide.

**Arch Enclosure:** The enclosure assembly shall consist of top supports, an extension tube, and an arched upright, which shall be constructed of 1" pipe, drilled, formed, and mashed, and vertical rungs which shall be constructed of 1" tube. The enclosure assembly shall be solid welded.

**Fasteners:** The assembly shall contain Versalok Fasteners and Fastener Style A hardware.

**Finishes:** The climber assemblies, arch enclosure, and clamps shall have a Mira-Cote finish. The Rockite bumpers used on Bumper Ladders shall have color molded in.

Consult Miracle's "Glossary of Technical Data for Materials, Processes and Finishes" for specifications of the underlined items.



**MIRACLE**  
RECREATION EQUIPMENT COMPANY

# Product Specifications

Oct. 3, 2000 Rev. B

Kids' Choice  
**Crunch Station**

**714-782**

**Crunch Station**

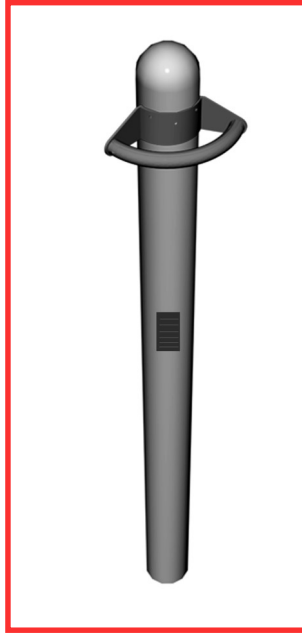

**Crunch Station**

**714-782**

# Kids' Choice Crunch Station

<u>MODEL #</u>	<u>PRODUCT</u>	<u>PROT. AREA</u>	<u>CONCRETE</u>
714-782	Crunch Station	6'-8" radius/post	See Post Spec.

## DESCRIPTION:

The Crunch Station is a semi-circular horizontal rung assembly designed for mounting on a 5" steel deck post with the rung set 50" - 80" from finished grade. The Crunch Station enables the user to perform leg lifts and crunches in a standing position.

## MATERIALS:

**Crunch Station:** The Crunch Station shall be constructed of a cut and formed 1" pipe segment solid welded to support and bolt plates of 7 ga. galvanized steel.

**Fasteners:** All hardware for deck and component attachment shall be Fastener Style A.

**Finish:** The Crunch Station shall have a Mira-Cote finish.

Consult Miracle's "Glossary of Technical Data for Materials, Processes & Finishes" for specifications of underlined items.



# PRODUCT SPECIFICATIONS

**Model 714-815: Vertical Ladder for 5' Deck**

**Model 714-815-3: Vertical Ladder for 3' Deck**

**Model 714-815-6: Look-Out Ladder for 6'-6" Deck**

**Model 714-815-8: Look-Out Ladder for 8' Deck**

Dec. 19, 2002 Rev. E



**714-815-3**

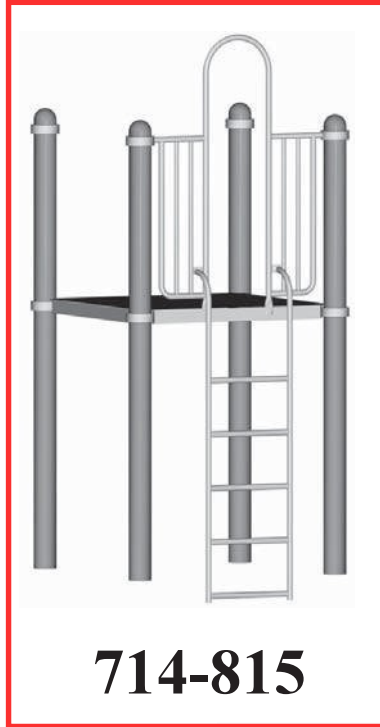

**714-815**



**714-815-6**



**714-815-8**

## PRODUCT SPECIFICATIONS

Model 714-815: Vertical Ladder for 5' Deck  
Model 714-815-3: Vertical Ladder for 3' Deck  
Model 714-815-6: Look-Out Ladder for 6'-6" Deck  
Model 714-815-8: Look-Out Ladder for 8' Deck  
Dec. 19, 2002 Rev. E

### **DESCRIPTION:**

The vertical ladder is used as an entry to or an exit from a 3', 5', 6'-6" or 8' high deck.

<b>Model</b>	<b>Ground Space</b>	<b>Deck Ht.</b>
714-815	3'-4" x 2"	5' deck
714-815-3	3'-4" x 2"	3' deck
714-815-6	3'-4" x 2"	6'-6" deck
714-815-8	3'-4" x 2"	8' deck

**Concrete for footing:** .10 cubic yards required.

### **MATERIALS:**

**Ladder:** The ladder consists of siderails with inserts and rungs, all constructed of 1" pipe, and all solid welded.

**Enclosure Assembly:** The enclosure assembly consists of top supports, a bottom support, and an arched upright, which are constructed of 1" pipe, drilled, formed, and mashed, and vertical rungs which are constructed of 1" tube. The enclosure assembly is solid welded.

**Fasteners:** All hardware is fastener style A.

**Versalok Fasteners:** All Versalok Fasteners for deck and component attachment are aluminum alloy.

**Finishes:** The ladder assemblies, enclosure assembly, and clamps have a Mira-Cote finish.

(CONSULT THE GLOSSARY OF TECHNICAL DATA FOR MATERIALS,  
PROCESSES AND FINISHES OF THE UNDERLINED ITEMS.)

**Kids' Choice®  
Wave Barriers**
**714-816W**
**Wave Barrier, Full Bar**

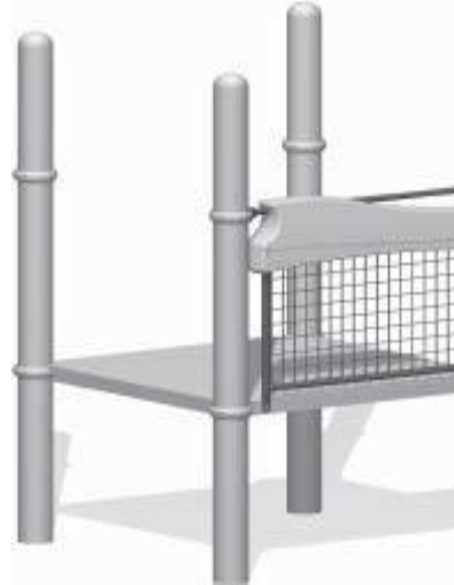
**714-8161W**
**Wave Barrier, Full Mesh**

Wave Barriers

**MODEL #**

 714-816-W  
714-816-1W

**PRODUCT**

 Wave Barrier, Full Bar  
Wave Barrier, Full Mesh

**DESCRIPTION**

The Wave Barrier is designed to provide fall protection on Kids' Choice Deck systems.

**MATERIALS**
**Bar Barrier:**

The barrier shall comprise a frame with uprights and rungs of 1.315" O.D. x 14 ga. galvanized, embossed tubing, fully welded. Brackets of 11 ga. galvanized sheet steel are stitch welded to the tubing to complete the frame. Top Barrier shall be Mira-Therm.

**Mesh Barrier:**

The barrier shall comprise a frame with uprights and rungs of 1.315" O.D. x 14 ga. galvanized, embossed tubing, fully welded. Brackets of 11 ga. galvanized sheet steel are stitch welded to the tubing to complete the frame. Top Barrier shall be Mira-Therm. Mesh shall be constructed of galvanized welded wire, 0.224" dia.

**Fasteners:**

The assembly shall contain Versalok Fasteners and Fastener Style A hardware.

**Finishes:**

The frame and clamps shall have a Mira-Cote finish. The Top Barrier shall be available in Mira-Therm finishes.

Consult Miracle's "Glossary of Technical Data for Materials, Processes & Finishes" for specifications of underlined items.

714-816W, 714-8161W

Kids' Choice® - Mira-Therm II

**Ramp 90° Level** - Between Decks MT II, Between Decks w/Arch, Open Handrail MT II

**714-856-L9**

**Ramp 90° Level Between Decks MT II**

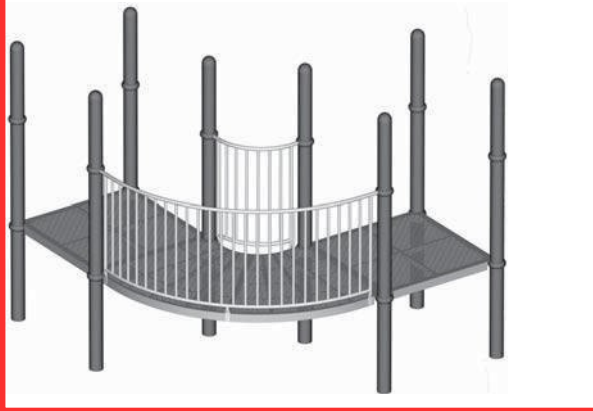

**714-856-L9A**

**Ramp 90° Level Between Decks w/Arch**



Note: Climber shown for position only, not included in assembly. Climber footing(s) must be located on-site during installation.

**714-856-L59**

**Ramp 90° Level Open Handrail MT II**

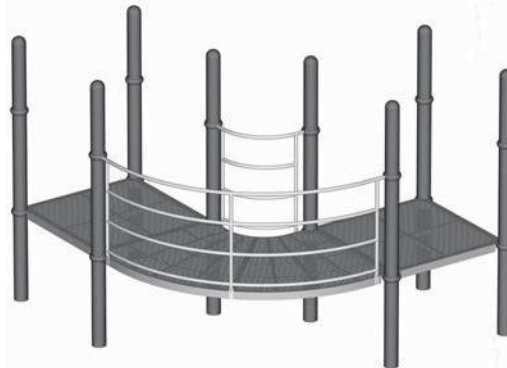

<u>MODEL</u>	<u>PRODUCT</u>	<u>GROUND SPACE</u>	<u>CONCRETE</u>
714-856-L9	Ramp 90° Level Between Decks MT II	6'-0" x 6'-0"	N/A
714-856-L9A	Ramp 90° Level Between Decks w/Arch	**	**
714-856-L59	Ramp 90° Level Open Handrail MT II	6'-0" x 6'-0"	N/A

\*\* Refer to planned climber specifications for ground space and concrete requirements.

**DESCRIPTION**

The Ramp 90° Level Between Decks are horizontal walkways between adjacent deck systems set at right angles to each other. Spoked or open handrails enclose the ramps on both sides. Model 714-856-L9A features an arch enclosure in the center of its spoked outer enclosure for attachment of a separate climber.

Consult Miracle's "Glossary of Technical Data for Materials, Processes and Finishes" for specifications of underlined items.

Ramp 90° Level

714-856-L9, 714-856-L9A, 714-856-L59

Kids' Choice® - Mira-Therm II

**Ramp 90° Level** - Between Decks MT II, Between Decks w/Arch, Open Handrail MT II

**MATERIALS**

**Ramp:** The PVC ramps shall be constructed with 11 ga. steel sheet perforated with a staggered pattern of 3/8" diameter holes at 5/8" apart center-to-center. The deck frame shall be constructed by folding edges to form 3" tall walls and shall be supported by solid welded braces of 1/4" x 1-1/2" flat.

**Spoked Handrails:** The spoked handrail assemblies shall consist of a top and bottom rail and uprights. The top and bottom rails shall be constructed of 1" pipe with in-fill uprights of 1" tube. The assembly shall contain end uprights and a single stub (on the outer enclosure's bottom rail) of 1" pipe with mashed ends for field attachment to the ramp. The entire assembly shall be solid welded.

**Arch Enclosure:** The arch enclosure shall comprise top supports, an extension tube, and arched upright, all constructed of 1" pipe, welded in the center of an outer spoked enclosure (described above). The arched upright shall be formed, mashed and punched.

**Open Handrails:** The open handrail assemblies shall consist of top, bottom and middle rails and uprights of 1" pipe. The uprights shall have mashed ends for field attachment to the ramp. The entire assembly shall be solid welded.

**Fasteners:** The assembly shall contain Versalok Fasteners and Fastener Style A hardware.

**Finishes:** The handrails and clamps shall be finished in Mira-Cote. The ramps shall have a Mira-Therm finish.

Consult Miracle's "Glossary of Technical Data for Materials, Processes and Finishes" for specifications of underlined items.



Kids' Choice®

## Steel Posts - 5" O.D., 13 ga. Round Tube

### Steel Posts - 5" O.D., 13 ga.

<u>MODEL</u>	<u>DESCRIPTION</u>	<u>USES</u>	<u>PART NUMBER</u>
714-549-13	88" Maze Post	Sensory Panel	925342*
714-549-33	112" Deck Post	3' Decks	995226*
714-549-43	124" Deck Post	4' Decks	995227*
714-551-3	106" Deck Post	2'-6" Decks & less	990728*
714-552-3	136" Deck Post	3' to 5' Decks	990729*
714-553-3	160" Deck Post	5'-6" to 6'-6" Decks	990730*
714-554-3	178" Deck Post	7' to 8' Decks	990731*
714-556-3	196" Deck Post	10' Deck	990808*
714-571-3	106" Post (Roof)	Ground Level	213008*
714-572-3	144" Deck Post (Roof)	3' Decks & less	990734*
714-573-3	168" Deck Post (Roof)	3'-6" to 5' Decks	990735*
714-574-3	186" Deck Post (Roof)	5'-6" to 6'-6" Decks	990736*
714-575-3	196" Deck Post (Uses 2 for Flippo Roof)	6'-6" Deck	990809*
714-576-3	204" Deck Post (Roof)	8' Deck	213018*

Note: An (\*) by a part number indicate: Color Code Required.

<b><u>CONCRETE</u></b>	0.13 cubic yards required per post
<b><u>DESCRIPTION</u></b>	Posts are used for support of deck systems and freestanding components.
<b><u>MATERIALS</u></b>	
<b>Steel Post Assembly:</b>	Steel posts shall be constructed of <u>5" tube, 13 ga.</u> Posts not designed for roof assemblies shall have <u>5" round end caps</u> pressed in at the factory.
<b>Fasteners:</b>	Components shall be field assembled to Posts by means of <u>Versalok Fasteners, Fastener Style A</u> hardware and/or <u>Fastener Style B</u> hardware.
<b>Finishes:</b>	Post assemblies and clamps shall be finished in <u>Mira-Cote.</u>

Consult Miracle's "Glossary of Technical Data for Materials, Processes and Finishes" for specifications of underlined items.

5" O.D., 13 ga. Steel Posts

714-549-13, 714-549-33, 714-549-43, 714-551-3, 714-552-3, 714-553-3, 714-554-3, 714-556-3, 714-571-3, 714-572-3, 714-573-3, 714-574-3, 714-575-3, 714-576-3

Kids' Choice®

**Vortex Groove II® Slides**

**714-638-4U**

4' Vortex Groove II Slide



**714-638-5U**

5' Vortex Groove II Slide



**714-638-6U**

6' & 6'-6" Vortex Groove II Slide



**714-638-8U**

8' VortexGroove II Slide



<b>MODEL #</b>	<b>PRODUCT</b>	<b>GRND SPC.</b>	<b>PROT. AREA</b>	<b>CONCRETE</b>
714-638-4U	4' Vortex Groove II Slide	2'-2" x 5'-9"	16' x 15'	.04 cu. yds.
714-638-5U	5' Vortex Groove II Slide	2'-2" x 7'-6"	20' x 15'	.04 cu. yds.
714-638-6U	6' & 6'-6" Vortex Groove II Slide	2'-2" x 10'-3"	24' x 15'	.08 cu. yds.
714-638-8U	8' Vortex Groove II Slide	2'-2" x 13'-1"	28' x 15'	.08 cu. yds.

**DESCRIPTION**

The Vortex Groove II Slides features a hooded canopy and a streamline slide design. Groove II is designed to exit from either a 4', 5', 6', 6'-6" or 8' Deck.

Vortex Groove II Slides

714-638-4U, 714-638-5U, 714-638-6U, 714-638-8U

Kids' Choice®

**Vortex Groove II® Slides****MATERIALS:**

- Slide:** The canopy panel and one-piece slide shall be constructed of double wall Rockite. The slide shall have 6" high side rails, an overall width of 25", an 18" wide sliding surface and approximate 7' (714-638-4), 9' (714-638-5), 12' (714-638-6) and 15' (714-638-8) bedway length. The canopy panel shall be field mounted to deck and to post clamps via a 41-1/2" long rung constructed of 1" pipe.
- Legs:** The legs shall be 2" pipe, welded to an 11 ga. A-60 Galvannealed mounting bracket.
- Fasteners:** Each assembly shall contain Versalok Fasteners and Fastener Style A hardware.
- Finishes:** The rung, legs, and clamps shall have a Mira-Cote finish. The Rockite slide and canopy shall have molded-in color.

**714-678-6**
**Backtrack Climber, 78"**

**714-678-8**
**Backtrack Climber, 96"**

**Backtrack Climber**
**MODEL #**

714-678-6

714-678-8

**PRODUCT**

Backtrack Climber, 78"

Backtrack Climber, 96"

**PROT AREA**

19'-4" X 16'-11"

19'-4" x 16'-11"

**CONCRETE**

0.09 cu. yds.

0.09 cu. yds.

**DESCRIPTION**

The Backtrack Climber is intended as a ground-to-deck climber.

**MATERIALS**
**Arch Entry Enclosure:**

The arch entry enclosure shall consist of a an arched upright and top rails of 1" pipe and vertical infill of 3/4" x 1" oval tube, all solid welded.

**Post Weldment:**

Post weldment shall comprise two posts constructed of RDTB ILG 88.9 mm x 3 mm, deck connection of 4.5 mm galvanized sheet, cross bar stub constructed of RDTB ILG 3.4 mm x 3 mm, and block swing hanger F/D Shackle ZN/YLW DI-CRO.

**Climber:**

Climber net shall be constructed of 19 mm rope with "D" style 300 ss large shackles.

**Fasteners:**

The assembly shall contain Versalok Fasteners and Fastener Style A hardware.

**Finishes:**

The post weldments, enclosure and clamps shall have a Mira-Cote finish.

Consult Miracle's "Glossary of Technical Data for Materials, Processes & Finishes" for specifications of underlined items.

714-678-6, 714-678-8

Kids' Choice®  
**Wave Roof**

**714-680-4C**  
Square Wave Roof with  
Topper



**714-680-6C**  
Hex Wave Roof with  
Topper



Wave Roof

**DESCRIPTION**

Wave Roofs shall act as an attractive roof to provide shade to your system.

**MATERIALS**

**Roof/Topper:** Roof and Post Topper shall be constructed of Rockite®.

**Post Weldments:** Post Weldment shall comprise an angle plate, cape and plate of 3 mm galvanized sheet, a tube support of RDTB ILG 60.3 mm x 2.7 mm, a 12.5 mm diameter steel rod roof support and a swage constructed of RDTB ILG 127.0 mm x 3.0 mm.

**Fasteners:** The assembly shall contain Versalok Fasteners and Fastener Style A hardware.

714-680-4C, 714-680-6C

Kids' Choice®  
**Wave Topper**

**714-680-4T**  
Square Wave Topper



**714-680-6T**  
Hex Wave Topper



Wave Topper

**DESCRIPTION**

Wave Toppers shall act as an attractive roof to provide shade to your system.

**MATERIALS**

**Post Topper**            Post topper shall be constructed of Rockite®.

**Fasteners:**            The assembly shall contain Versalok Fasteners and Fastener Style A hardware.

714-680-4T, 714-680-6T

Kids' Choice®  
**Avalanche Slide**
**714-682-5**
**Avalanche Slide W/Tubes**

**714-682-51**
**Avalanche Slide w/Mesh**

**Avalanche Slide**

<u>MODEL #</u>	<u>PRODUCT</u>	<u>PROT. AREA</u>	<u>GROUND SPACE</u>	<u>CONCRETE</u>
714-682-5	Avalanche Slide w/Tubes	21'-3" x 20'-4"	10' x 7'-7"	0.17 cu. yds.
714-682-51	Avalanche Slide w/Mesh	21'-3" x 20'-4"	10' x 7'-7"	0.17 cu. yds.

**DESCRIPTION**

The Wave Barrier is designed to provide fall protection on Kids' Choice Deck systems.

**MATERIALS**

**Bar Barrier:** The barrier shall comprise a frame with uprights and rungs of 1.315" O.D. x 14 ga. galvanized, embossed tubing, fully welded. Brackets of 11 ga. galvanized sheet steel are stitch welded to the tubing to complete the frame. Top Barrier shall be Mira-Therm.

**Mesh Barrier:** The barrier shall comprise a frame with uprights and rungs of 1.315" O.D. x 14 ga. galvanized, embossed tubing, fully welded. Brackets of 11 ga. galvanized sheet steel are stitch welded to the tubing to complete the frame. Top Barrier shall be Mira-Therm. Mesh shall be constructed of galvanized welded wire, 0.224" dia.

**Slide Legs:** Legs shall comprise a support and a foot. Support tube shall be constructed of RDTB ILG 42.2 mm x 2.3 mm welded to a vertical constructed of RDTB ILG 33.4 mm x 3 mm. Foot shall be mashed on one end and constructed of RDTB ILG 33.4 mm x 2.3 mm.

Consult Miracle's "Glossary of Technical Data for Materials, Processes & Finishes" for specifications of underlined items.

714-682-5, 714-682-51

Kids' Choice®  
**Avalanche Slide**

**Avalanche Slide:** Slide shall be constructed of Rock-ite and shall feature 3 graduating slide bedways.

**Fasteners:** The assembly shall contain Versalok Fasteners and Fastener Style A hardware.

**Finishes:** The frame and clamps shall have a Mira-Cote finish. The Top Barrier shall be available in Mira-Therm finishes.

**Avalanche Slide**

714-682-5, 714-682-51

Consult Miracle's "Glossary of Technical Data for Materials, Processes & Finishes" for specifications of underlined items.



# Product Specifications

April 14, 2005

Rev. C

**MIRACLE**  
RECREATION EQUIPMENT COMPANY

Kids' Choice® - Mira-Therm II

ADA **Stairs Between Decks** - 1', 2', 2'-6" & 1'-6" Rise

**714-810-9 & 714-959-9**

714-959-59 & 714-959-49

714-959-459

5 additional stair models

**Stair (ADA) - 1' Rise Between Decks with Spoked Handrails, 1'-4" Span**

**Stair (ADA) - 2' Rise Between Decks with Spoked Handrails, 4'-6" Span**

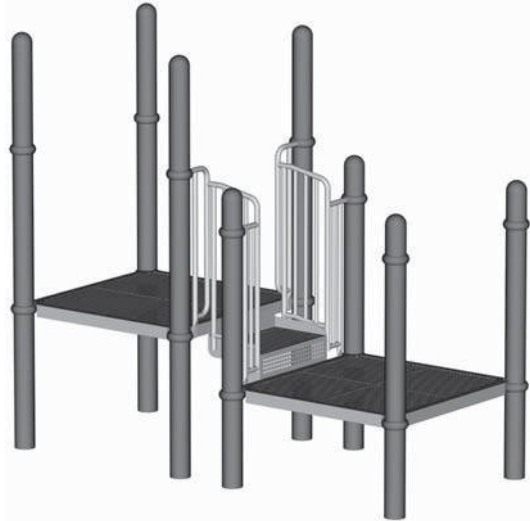

714-810-9 & 714-959-9

**714-959-59 & 714-959-49**

714-959-459

5 additional stair models

**Stair (ADA) - 2' Rise Between Decks with Open Handrails, 4'-6" Span**

**Stair (ADA) - 2' Rise Between Decks with Spoked Handrails, 4'-0" Span**

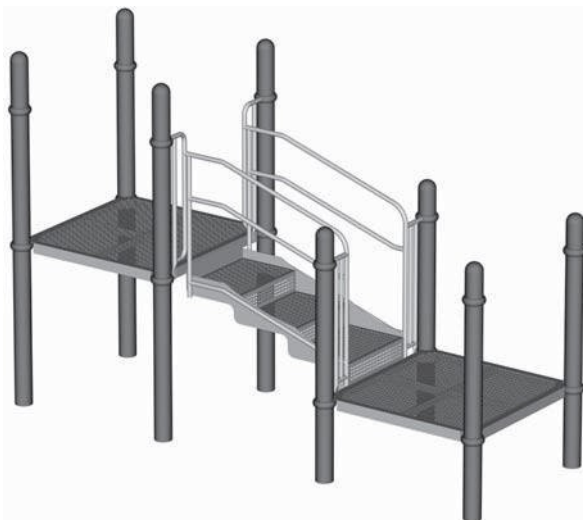

ADA Stairs Between Decks

714-810-9, 714-959-9, 714-959-59, 714-959-49, 714-959-459, 714-960-9, 714-993-9, 714-993-59, 714-993-49, 714-993-459

Kids' Choice® - Mira-Therm II  
ADA **Stairs Between Decks**

714-810-9 & 714-959-9

714-959-59 & 714-959-49

**714-959-459**

5 additional  
stair models

**Stair (ADA) - 2' Rise Between Decks  
with Open Handrails, 4'-0" Span**

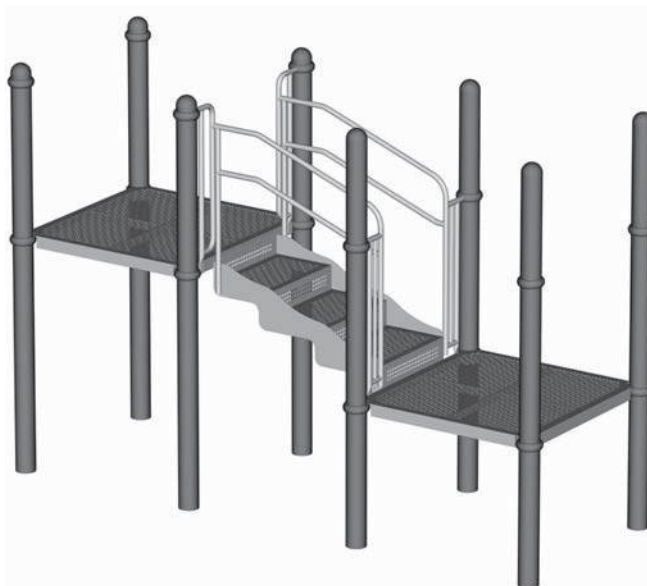

5 additional  
stair models

**714-960-9**

714-993-9 & 714-993-59

714-993-49 & 714-993-459

**Stair (ADA) - 2'-6" Rise Between Decks  
with Spoked Handrails, 6'-0" Span**





Kids' Choice® - Mira-Therm II  
ADA **Stairs Between Decks**

5 additional  
stair models

714-960-9

714-993-9 & 714-993-59

714-993-49 & 714-993-459

**Stair (ADA) - 1'-6" Rise Between Decks with Spoked Handrails, 3'-0" Span**



**Stair (ADA) - 1'-6" Rise Between Decks with Open Handrails, 3'-0" Span**

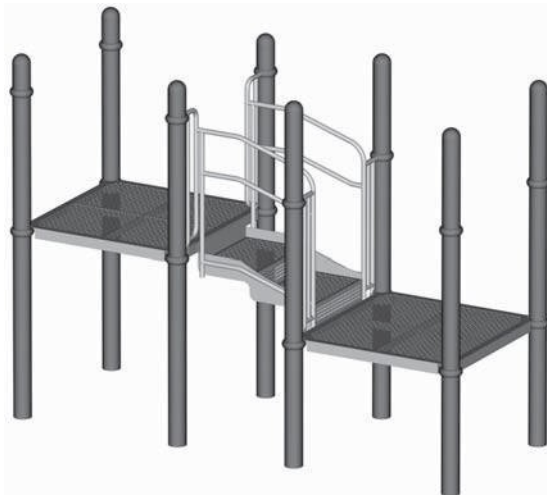

5 additional  
stair models

714-960-9

714-993-9 & 714-993-59

714-993-49 & 714-993-459

**Stair (ADA) - 1'-6" Rise Between Decks with Spoked Handrails, 4'-0" Span**



**Stair (ADA) - 1'-6" Rise Between Decks with Open Handrails, 4'-0" Span**

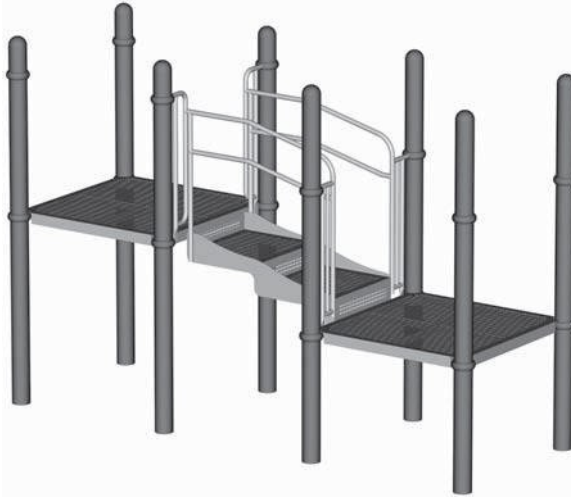

ADA Stairs Between Decks

714-810-9, 714-959-9, 714-959-59, 714-959-49, 714-959-459, 714-960-9, 714-993-9, 714-993-59, 714-993-49, 714-993-459

Kids' Choice® - Mira-Therm II  
**ADA Stairs Between Decks**

<u>MODEL #</u>	<u>PRODUCT</u>
714-810-9	ADA Stair Between Decks, 1' Rise, Spoked Handrails, 1'-4" Span
714-959-9	ADA Stairs Between Decks, 2' Rise, Spoked Handrails, 4'-6" Span
714-959-59	ADA Stairs Between Decks, 2' Rise, Open Handrails, 4'-6" Span
714-959-49	ADA Stairs Between Decks, 2' Rise, Spoked Handrails, 4'-0" Span
714-959-459	ADA Stairs Between Decks, 2' Rise, Open Handrail, 4'-0" Span
714-960-9	ADA Stairs Between Decks, 2'-6" Rise, Spoked Handrails, 6'-0" Span
714-993-9	ADA Stairs Between Decks, 1'-6" Rise, Spoked Handrails, 3'-0" Span
714-993-59	ADA Stairs Between Decks, 1'-6" Rise, Open Handrails, 3'-0" Span
714-993-49	ADA Stairs Between Decks, 1'-6" Rise, Spoked Handrails, 4'-0" Span
714-993-459	ADA Stairs Between Decks, 1'-6" Rise, Open Handrails, 4'-0" Span

**DESCRIPTION**

These ADA-compliant stairs connect decks of differing heights and include handrails.

**MATERIALS**

- Steps:** The wide step assemblies, approximately 26-3/8" before PVC-dip coating, shall be constructed of steel stringers solid welded to formed treads of 11 ga. steel sheet that are perforated with a staggered pattern of 3/8" diameter holes at 5/8" apart center-to-center. The braces shall be constructed of 11 ga. black.
- Spoked Handrails:** Spoked handrail enclosures shall consist of a top and bottom rail and newel post, all of 1" pipe, and uprights of 3/4" x 1" oval tube, all solid welded. The top rails shall contain 3/8" aluminum inserts. Plastic pipe plugs shall close open ends.
- Open Handrails:** Open handrail enclosures shall consist of a top and bottom rail and newel post, all of 1" pipe, solid welded. The top rails shall contain 3/8" aluminum inserts. Plastic pipe plugs shall close open ends.
- Top Stair Enclosure:** The top stair enclosure shall consist of enclosure rails and an upright, both of 1" pipe, drilled and solid welded. The upright shall be mashed on one end.
- Bottom Deck Enclosure:** The bottom deck enclosure shall consist of enclosure rails and an upright of 1" pipe, drilled, and a spoke of 3/4" x 1" oval tube, all solid welded. The upright shall be mashed on one end. Plastic pipe plugs shall close open ends.
- Fasteners:** The assembly shall contain Versalok Fasteners and Fastener Style A hardware.
- Finishes:** The stairs shall be finished in Mira-Therm. The handrails, enclosures, and clamps shall have a Mira-Cote finish.

Consult Miracle's "Glossary of Technical Data for Materials, Processes & Finishes" for specifications of underlined items.



# Product Specifications

Kids' Choice®  
Loop Seat

**714-817-1B**  
**Loop Seat**



Loop Seat

<u>MODEL #</u>	<u>PRODUCT</u>	<u>PROT. AREA</u>	<u>GRND. SPC.</u>
714-817-1B	Loop Seat	17' x 13'-10"	4'-6" x 1'-4"

**DESCRIPTION**

The Loop Seat is an inventive, economical way for kids to rest between play. The Loop Seat easily installs between existing Deck Posts and is situated at a comfortable 45° angle to create a combination seat and back rest.

**MATERIALS**

**Loop Seat:** The Loop Seat shall consist of two loop halves constructed of 2" pipe, solid welded to each other to create one Loop Seat. Each loop half shall measure 32-5/8" in length and 14-13/16" in height. Two 4-3/8" stubs shall be solid welded to short sides of Loop Seat and shall be constructed of 2" pipe.

**Fasteners:** The assembly shall contain Versalok Fasteners and Fastener Style A hardware.

**Finishes:** The Loop Seat shall be finished in Mira-Cote.

Consult Miracle's "Glossary of Technical Data for Materials, Processes & Finishes" for specifications of underlined items.

714-817-1B

Kids' Choice® - Mira-Therm™ II

9'-4" & 12' Typhoon Slides w/Domed Wave Hood from 5', 6', 6'-6", 8' and 10' Decks

**71475959U**

Typhoon Slide w/Domed Wave Hood from 5' Deck, 630°, 9'-4" Platform

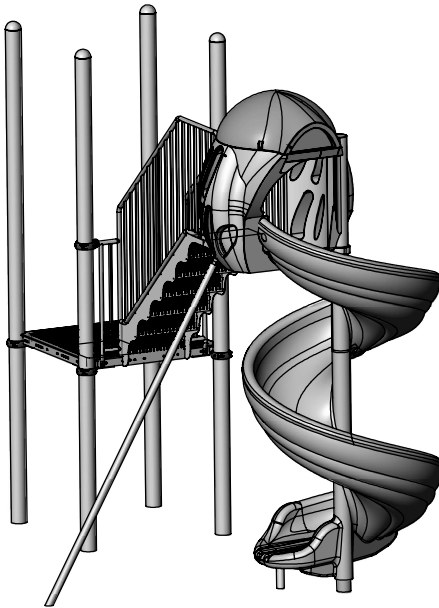

**714-759-69U & 714-759-69UC**

Typhoon Slide w/Domed Wave Hood from 6' & 6'-6" Deck, 630°, 9'-4" Platform

Typhoon Slide w/Domed Wave Hood from 6' & 6'-6" Deck, 630°, 9'-4" Platform, CSA

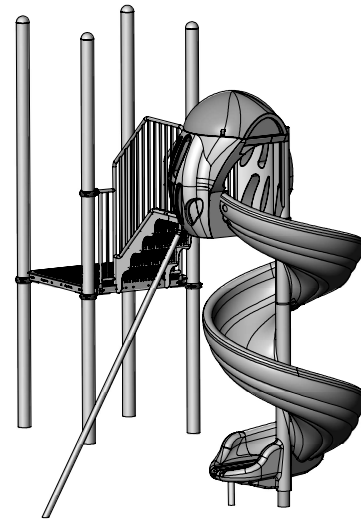

**714-769-69U**

Typhoon Slide w/Domed Wave Hood from 6' & 6'-6" Deck, 855°, 12' Platform

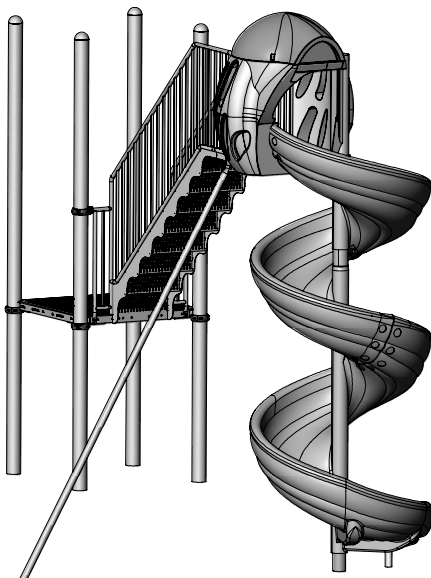

**714-769-89U**

Typhoon Slide w/Domed Wave Hood from 8' Deck, 855°, 12' Platform

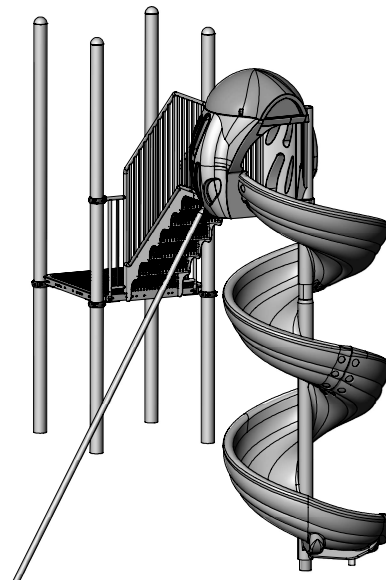

Typhoon Slides w/Domed Wave Hood

714-759-59U, 714-759-69U, 714-769-69U, 714-769-69UC, 714-769-89U, 714-769-89UC, 714-769-109U

Kids' Choice® - Mira-Therm™ II

**9'-4" & 12' Typhoon Slides w/Domed Wave Hood from 5', 6', 6'-6", 8' and 10' Decks**

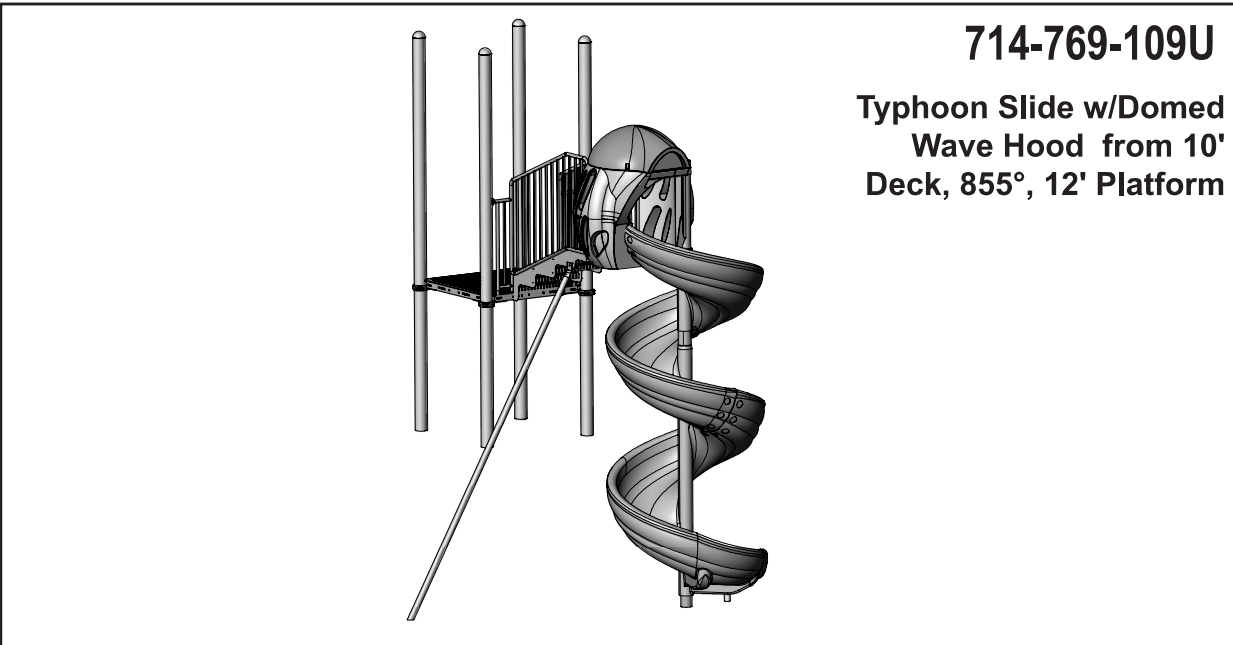

**714-769-109U**

**Typhoon Slide w/Domed Wave Hood from 10' Deck, 855°, 12' Platform**

<u>MODEL #</u>	<u>PRODUCT</u>	<u>OVERALL HT.</u>	<u>GRND SPC.</u>	<u>PROT. AREA</u>	<u>CONCRETE</u>
714-759-59U	Typhoon Slide from 5' Deck, 9'-4" Platform	13'-10"	9'-3" x 9'-5"	22'-8" x 24'-4"	0.40 cu. yds.
714-759-69U	Typhoon Slide from 6' & 6'-6" Deck, 9'-4" Platform	13'-10"	8'-2" x 9'-5"	21'-7" x 22'-7"	0.40 cu. yds.
714-759-69CU	Typhoon Slide from 6' & 6'-6" Deck, 9'-4" Platform	13'-10"	8'-2" x 9'-5"	21'-7" x 22'-7"	0.40 cu. yds.
714-769-69U	Typhoon Slide from 6' & 6'-6" Deck, 12' Platform	16'-6"	8'-9" x 10'-10"	23'-6" x 24'-6"	0.40 cu. yds.
714-769-89U	Typhoon Slide from 8' Deck, 12' Platform	16'-6"	8'-9" x 9'-3"	23'-10" x 24'	0.40 cu. yds.
714-769-109U	Typhoon Slide from 10' Deck, 12' Platform	16'-6"	8'-8" x 8'-11"	22' x 23'-8"	0.40 cu. yds.

**DESCRIPTION**

These Typhoon slides are 630° and 855° open bedway spiral slides with step assemblies and domed wave hood, featuring platform heights of 9'-4" and 12', designed for attachment to 5', 6', 6'-6", 8' and 10' decks.

**MATERIALS**

**Slide Assembly:** The slide bedway shall be constructed of 1/4" to 5/16" wall Rockite. The slide bedway shall be 30" wide with a 15" high sidewall. The center post shall be constructed of 4" pipe.

**Step Assembly/  
Stair Extension:** The step assembly and stair extension shall be constructed of 11 ga. steel sheet folded and perforated with a staggered pattern of 3/8" diameter holes at 5/8" apart center-to-center, solid welded to stringers of 11 ga. black steel.

**Handrail Assembly:** The handrail assembly shall consist of a top and bottom rail and newel post, formed, constructed of 1" pipe with infill of 3/4" x 1" oval tube. The step enclosure assembly shall be solid welded. Plastic pipe plugs shall close open ends.

Kids' Choice® - Mira-Therm™ II

## 9'-4" & 12' Typhoon Slides w/Domed Wave Hood from 5', 6', 6'-6", 8' and 10' Decks

### MATERIALS

**Diagonal Brace:** The diagonal brace shall be constructed of 2" pipe and shall measure 17'.

**Deck Enclosures:** The deck enclosures shall consist of a vertical rail, and top and bottom rail, formed, constructed of 1" pipe with an upright of 3/4" x 1" oval tube, and 3/8" aluminum inserts in the rail ends for attachment to the step enclosures. The deck enclosure assembly shall be solid welded.

**Slide Hood:** The slide hood shall be Rockite with molded-in view grooves for viewing children.

**Back-up Plates:** The back-up plates used to connect the step assembly and the barrel shall be constructed of 1/4" x 1" x 6" flat steel.

**Front Leg:** The front leg shall be constructed of 2" pipe and shall be attached to the slide using a channel constructed of 7 ga. sheet.

**Fasteners:** The assembly shall contain Versalok Fasteners and Fastener Style A hardware.

**Finishes** The Rockite slide and platform canopy shall have color molded in. The step shall be finished in Mira-Therm. The handrail assemblies, deck enclosures, front leg assembly, and clamps shall have a Mira-Cote finish. The back-up plates shall have an aluminum finish.

Kids' Choice® - Mira-Therm II™

**Square Transfer Points - 3', 4', 5', 6' & 6'-6" Decks with Closed or Open Handrails**

Deck systems not included in these assemblies.

**714-851-39**

**Square Transfer Point for 3' Deck, Closed Bottom step to exit LEFT**

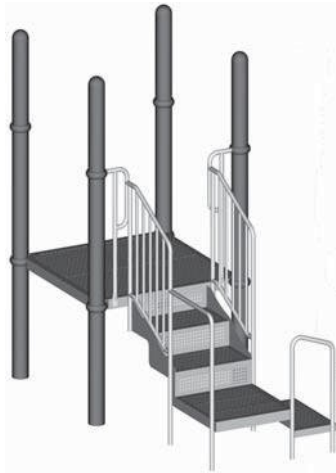

**714-851-359**

**Square Transfer Point for 3' Deck, Open Bottom step to exit LEFT**

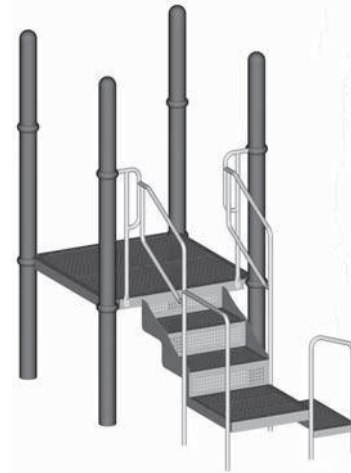

**714-851-39**

**Square Transfer Point for 3' Deck, Closed Bottom step to exit RIGHT**

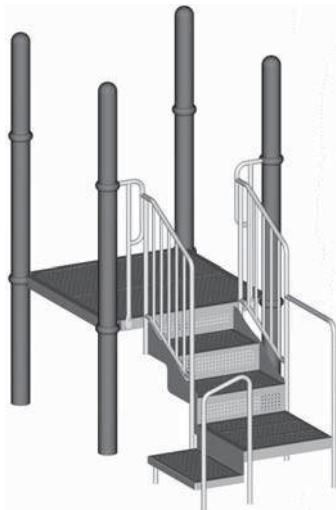

**714-851-359**

**Square Transfer Point for 3' Deck, Open Bottom step to exit RIGHT**

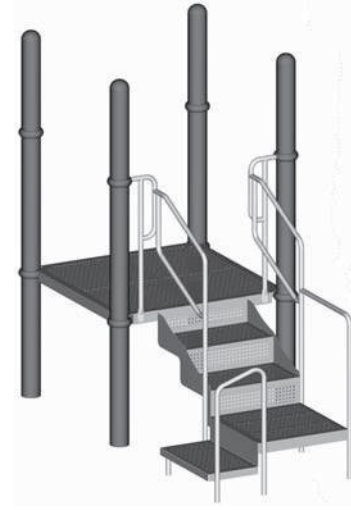

Square Transfer Points

714-851-39, 714-851-359, 714-851-49, 714-851-459, 714-851-59, 714-851-69

Kids' Choice® - Mira-Therm II™

# Square Transfer Points - 3', 4', 5', 6' & 6'-6" Decks with Closed or Open Handrails

Deck systems not included in these assemblies.

## 714-851-39

Square Transfer Point for 3' Deck, Closed Bottom step to exit STRAIGHT with handrail on LEFT

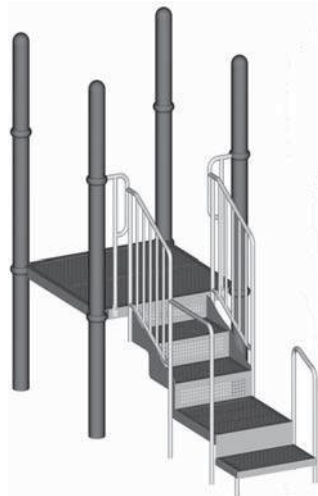

## 714-851-359

Square Transfer Point for 3' Deck, Open Bottom step to exit STRAIGHT with handrail on LEFT

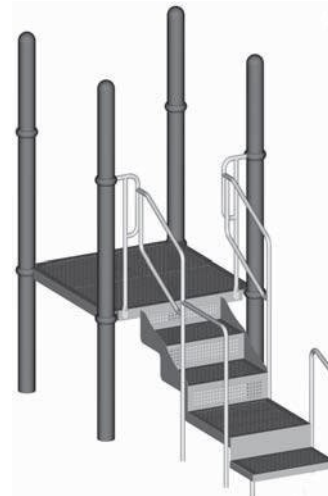

## 714-851-39

Square Transfer Point for 3' Deck, Closed Bottom step to exit STRAIGHT with handrail on RIGHT

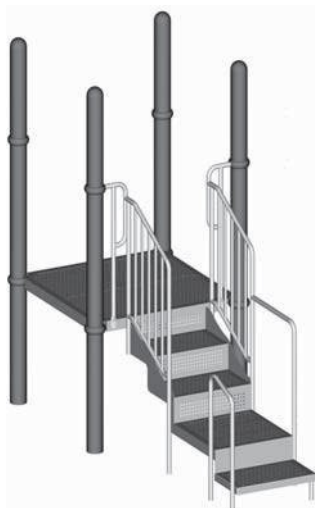

## 714-851-39

Square Transfer Point for 3' Deck, Open Bottom step to exit STRAIGHT with handrail on RIGHT

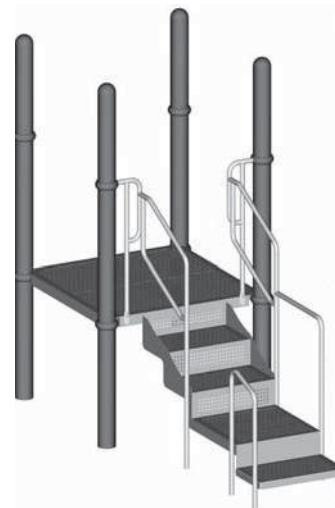

Kids' Choice® - Mira-Therm II™

## Square Transfer Points - 3', 4', 5', 6' & 6'-6" Decks with Closed or Open Handrails

Deck systems not included in these assemblies.

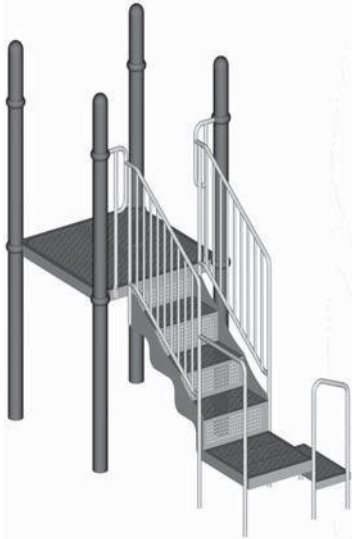
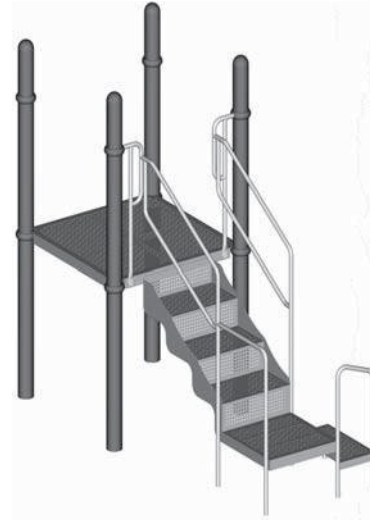
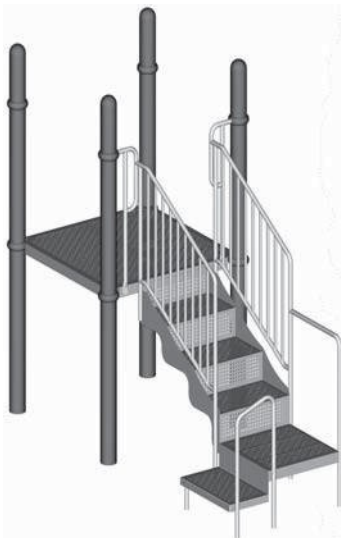
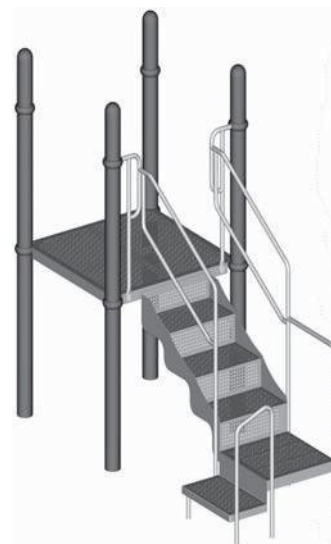
**714-851-49**
**Square Transfer Point for 4' Deck, Closed  
Bottom step to exit LEFT**

**714-851-459**
**Square Transfer Point for 4' Deck, Open  
Bottom step to exit LEFT**

**714-851-49**
**Square Transfer Point for 4' Deck, Closed  
Bottom step to exit RIGHT**

**714-851-459**
**Square Transfer Point for 4' Deck, Open  
Bottom step to exit RIGHT**

Kids' Choice® - Mira-Therm II™

### Square Transfer Points - 3', 4', 5', 6' & 6'-6" Decks with Closed or Open Handrails

Deck systems not included in these assemblies.

**714-851-49**

**Square Transfer Point for 4' Deck, Closed Bottom step to exit STRAIGHT with handrail on LEFT**

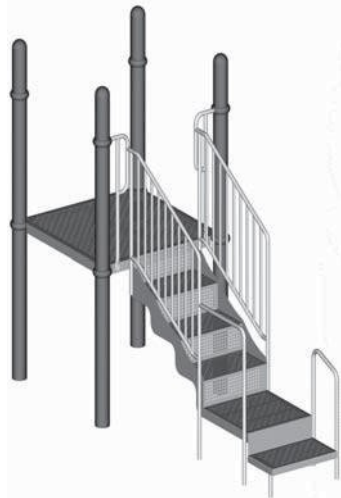

**714-851-459**

**Square Transfer Point for 4' Deck, Open Bottom step to exit STRAIGHT with handrail on LEFT**

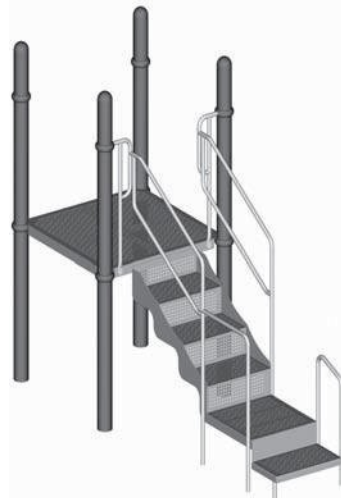

**714-851-49**

**Square Transfer Point for 4' Deck, Closed Bottom step to exit STRAIGHT with handrail on RIGHT**



**714-851-459**

**Square Transfer Point for 4' Deck, Open Bottom step to exit STRAIGHT with handrail on RIGHT**

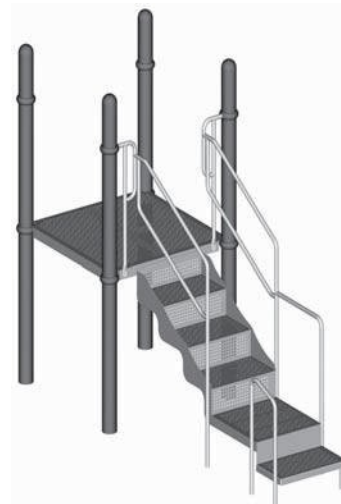

Kids' Choice® - Mira-Therm II™

## Square Transfer Points - 3', 4', 5', 6' & 6'-6" Decks with Closed or Open Handrails

Deck systems not included in these assemblies.

**714-851-59**

**Square Transfer Point for 5' Deck, Closed Bottom step to exit LEFT**



**714-851-59**

**Square Transfer Point for 5' Deck, Closed Bottom step to exit RIGHT**



**714-851-59**

**Square Transfer Point for 5' Deck, Closed Bottom step to exit STRAIGHT with handrail on LEFT**



**714-851-59**

**Square Transfer Point for 5' Deck, Closed Bottom step to exit STRAIGHT with handrail on RIGHT**



Kids' Choice® - Mira-Therm II™

# Square Transfer Points - 3', 4', 5', 6' & 6'-6" Decks with Closed or Open Handrails

Deck systems not included in these assemblies.

**714-851-69**

**Square Transfer Point for 6' & 6'-6"  
Deck, Closed  
Bottom step to exit LEFT**



**714-851-69**

**Square Transfer Point for 6' & 6'-6"  
Deck, Closed  
Bottom step to exit RIGHT**

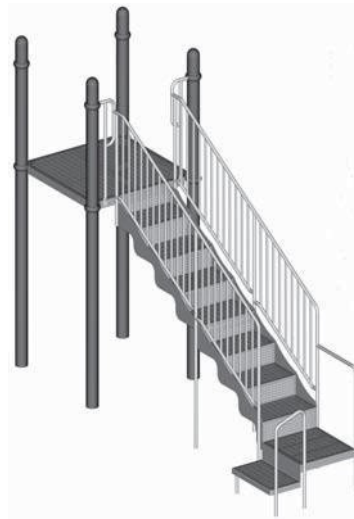

**714-851-69**

**Square Transfer Point for 6' & 6'-6"  
Deck, Closed  
Bottom step to exit STRAIGHT**



**714-851-69**

**Square Transfer Point for 6' & 6'-6"  
Deck, Closed  
Bottom step to exit STRAIGHT**



714-851-39, 714-851-359, 714-851-49, 714-851-459, 714-851-59, 714-851-69

Kids' Choice® - Mira-Therm II™

## Square Transfer Points - 3', 4', 5', 6' & 6'-6" Decks with Closed or Open Handrails

Deck systems not included in these assemblies.

<u>MODEL #</u>	<u>PRODUCT</u>	<u>ORIENTATION</u>	<u>GRND. SPC.</u>	<u>PROT. AREA</u>	<u>CONCRETE</u>
714-851-39	Sqr. Transfer Point, 3' Dk, Closed	Left or Right ...	4'-9" x 4'-0"	17'-2" x 16'-0"	0.30 cu. yds.
		Straight ...	5'-10" x 3'-6"	18'-3" x 14'-11"	0.30 cu. yds.
714-851-359	Sqr. Transfer Point, 3' Dk, Open	Left or Right ...	4'-9" x 4'-0"	17'-2" x 16'-0"	0.30 cu. yds.
		Straight ...	5'-10" x 3'-6"	18'-3" x 14'-11"	0.30 cu. yds.
714-851-49	Sqr. Transfer Point, 4' Dk, Closed	Left or Right ...	5'-11" x 4'-1"	18'-4" x 16'-0"	0.30 cu. yds.
		Straight ...	7'-0" x 3'-6"	19'-5" x 14'-11"	0.30 cu. yds.
714-851-459	Sqr. Transfer Point, 4' Dk, Open	Left or Right ...	5'-11" x 4'-1"	18'-4" x 16'-0"	0.30 cu. yds.
		Straight ...	7'-0" x 3'-6"	19'-5" x 14'-11"	0.30 cu. yds.
714-851-59	Sqr. Transfer Point, 5' Dk, Closed	Left or Right ...	8'-3" x 4'-0"	20'-9" x 16'-0"	0.30 cu. yds.
		Straight ...	9'-4" x 3'-6"	21'-10" x 14'-11"	0.30 cu. yds.
714-851-69	Sqr. Transfer Point, 6' Dk, Closed	Left or Right ...	10'-8" x 4'-1"	23'-1" x 16'-0"	0.40 cu. yds.
		Straight ...	11'-9" x 3'-6"	24'-2" x 14'-11"	0.40 cu. yds.

### DESCRIPTION

These models are designed to assist disabled users gain access to and egress from a deck system.

### MATERIALS

<b>Stair Assembly:</b>	Each stair assembly shall be constructed of 11 ga. steel stringers solid <u>welded</u> to 11 ga. steel sheet decking that is perforated in a staggered pattern of 3/8" diameter holes at 5/8" apart center-to-center. Approximate dimensions of stair assembly shall be 26" overall width, 14" deep step tread and 8" high step rise.
<b>Transfer Point Deck:</b>	Each 26" square (approximate) transfer point deck shall be constructed of 11 ga. steel sheet folded to form approximately 3" high sidewalls. The decking shall be perforated in a staggered pattern of 3/8" diameter holes at 5/8" apart center-to-center. It shall be reinforced with cross braces of 3/16" x 2" HR flat solid <u>welded</u> .
<b>Bottom Step:</b>	The bottom step shall be constructed of 11 ga. steel sheet (with folded edges) perforated in an identical pattern. The step shall be approximately 26" wide by 14" deep by 6-1/2" high.
<b>Deck Enclosures:</b>	Deck enclosures shall be constructed of formed 1" <u>pipe</u> , including a <u>welded</u> upright of the same material. Each assembly shall be drilled for field assembly of a stair handrail, and shall have its bottom end mashed and punched for field assembly to deck.

Kids' Choice® - Mira-Therm II™

## Square Transfer Points - 3', 4', 5', 6' & 6'-6" Decks with Closed or Open Handrails

Deck systems not included in these assemblies.

### MATERIALS (continued)

**Stair Handrail and Stair/Deck Handrail:**

Stair handrail assemblies shall be welded upper and lower handrails of formed 1" pipe. Closed handrails shall contain vertical uprights of 3/4" x 1" oval tube welded within. Swaged handrail extensions for field assembly to handrails shall be constructed of 1" pipe. A transfer deck handrail constructed of formed 1" pipe shall be field assembled to one handrail newel upright and transfer point deck edge. Models designed for assembly to 5' and 6' or 6'-6" decks shall contain handrail sleeve supports constructed of 1-1/4" pipe, 10 ga.

**Transfer Step Handrail:**

The "U"-shaped transfer step handrail shall be formed 1" pipe, drilled for field assembly to transfer point deck and bottom step. Its apex shall be 36-1/8" from finished grade.

**Rung Leg:**

The rung leg shall be 1" pipe with ends mashed and punched for field assembly to bottom step.

**Fasteners:**

Each assembly shall contain Versalok Fasteners and Fastener Style A hardware.

**Finishes:**

The stairs, bottom step, and transfer point deck shall be finished in Mira-Therm. The deck enclosures, handrails, extensions, sleeves, and leg shall be finished in Mira-Cote.

Consult Miracle's "Glossary of Technical Data for Materials, Processes & Finishes" for specifications of underlined items.

## Risk Management Sign

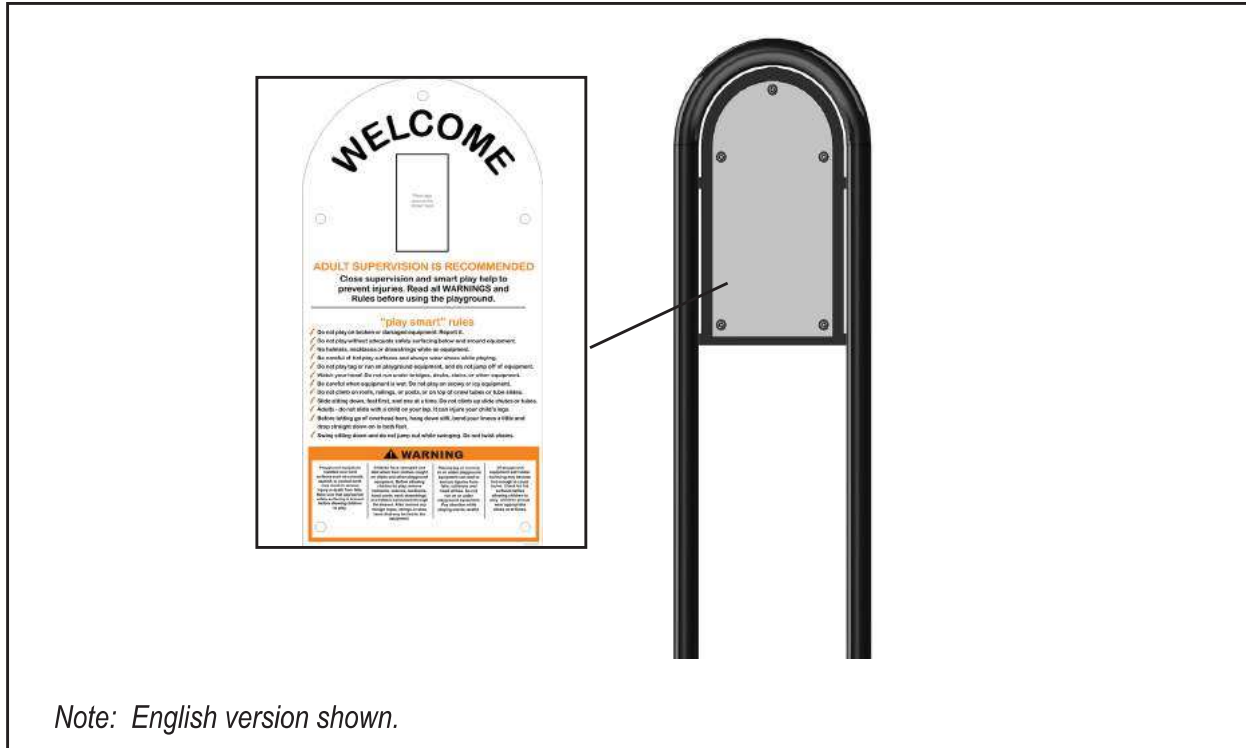

Note: English version shown.

<u>MODEL</u>	<u>PRODUCT</u>	<u>GROUND SPACE</u>	<u>CONCRETE</u>
787	Risk Management Sign - English	1'-6" x 3'-6"	0.09 cu. yd.
787FR	Risk Management Sign - French	1'-6" x 3'-6"	0.09 cu. yd.
787FRENG	Risk Management Sign - French/English	1'-6" x 3'-6"	0.09 cu. yd.
787SP	Risk Management Sign - Spanish	1'-6" x 3'-6"	0.09 cu. yd.
787BD	Risk Management Sign - English Surface MT	1'-6" x 3'-6"	site specific
787BDFR	Risk Management Sign - French Surface MT	1'-6" x 3'-6"	site specific
787BDFRENG	Risk Management Sign - French/English SM	1'-6" x 3'-6"	site specific
787BDSP	Risk Management Sign - Spanish Surface MT	1'-6" x 3'-6"	site specific

### DESCRIPTION

The Risk Management Sign is intended to inform the parents and children that adult supervision is recommended, along with smart play on the equipment in the play area.

### MATERIAL

- Sign:** Fiberglass embedded, gloss finish, 0.125" thick.
- Steel Frame:** 2-3/8" OD 12 gauge galvanized steel tubing, 13 gauge galvanized steel sheet for mounting sign, and 3/8" thick hot rolled steel base plate on each leg.
- Extension Tube:** 2.375 12GA GLV-IL X 24' tube round.
- Hardware:** Stainless steel that requires tooling to install or remove.
- Finish:** The frame shall have a Mira-Cote finish.

## Bug Bites® "C" Spring Rider - Lucky

**IMPORTANT!** Prior to installation of any components, refer to **Playsystem Installation Guidelines and Tips** in the *Install 101* section of your manual. This section will provide important tips pertaining to **site preparation, footings, system stabilization**, and other necessary information **vital to the success of your installation.**



<u>MODEL</u>	<u>PRODUCT</u>	<u>GRND SPACE</u>	<u>PROT. AREA</u>	<u>CONCRETE</u>
960	"C" Spring Rider - Lucky	2'-11" x 4'-4"	17' x 16'	0.25 cu. yds.

DESCRIPTION

This "C" Spring Rider is designed to provide children with an engaging, fun and safe physical activity that stimulates imaginative play while encouraging sharing and cooperation. "C" Spring Riders feature traditional "rocking horse" type movement using one "flat strip" style spring, formed into a "C" shape. Model # 960 is shaped like a ladybug.

MATERIAL

- Rider Body:** The rider body shall consist of a Rockite figure supported by a body frame. Wall thickness of molded components shall be 3/16" to 1/4". The body frame shall consist of front and/or rear supports constructed of 1-1/2" tube and/or of 2" x 2" x 1/4" angle, a cross member constructed of 1-1/4" pipe, and handholds of Gator Grip.
- "C" Spring:** The "C" springs shall be constructed of 3/8" or 7/16" spring steel, 4" wide by approximately 41-1/2" long, bent 180 degrees to form a large "C".
- Pinch Plate:** Pinch Plates shall be constructed of 1/4" flat sheet.
- Base Weldment:** Base Weldments shall comprise an anchor plate constructed of 1/8" x 2" flat sheet, a bracket of 7 ga. sheet, and a center tube constructed of 5" tube, all solid welded.
- Fasteners:** All hardware shall be Fastener style A.
- Finish:** The Rockite rider bodies shall have color molded in. Lucky shall have molded in color for the spots and molded in decals for the eyes. Handholds shall have a galvanized finish. The "C" springs shall be finished in Mira-Cote™.

"C" Spring Rider - Lucky

960

Webscapes™ Activity Nets

**Libra**® (2m), **Pegasus**™ (4m) and **Aquarius**® (6m) - In Ground

**4422**

**Libra (2m) Activity Net**

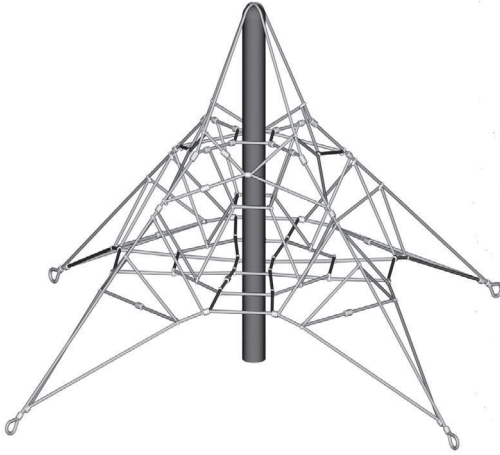

**4424**

**Pegasus (4m) Activity Net**

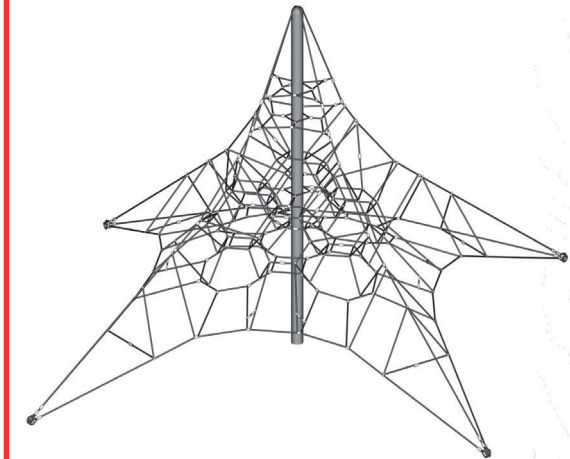

**4426**

**Aquarius (6m) Activity Net**

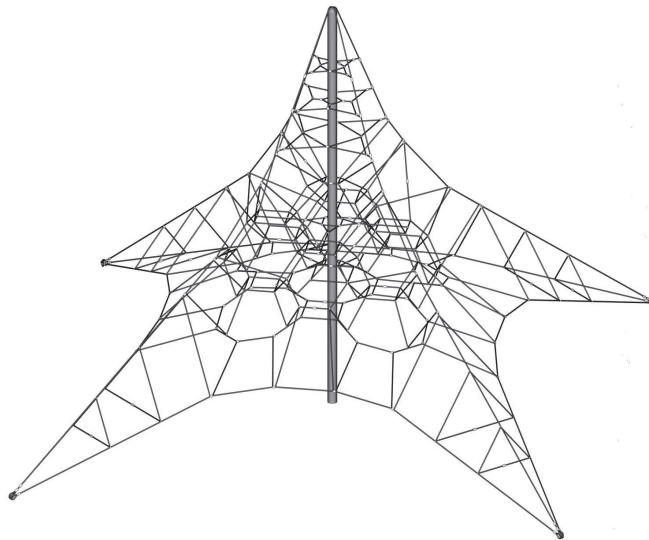

Consult Miracle's "Glossary of Technical Data for Materials, Processes and Finishes" for specifications of underlined items.

**Webscapes™ Activity Nets**  
**Libra® (2m), Pegasus™ (4m) and Aquarius® (6m) - In Ground**

<u>MODEL</u>	<u>PRODUCT</u>	<u>GRND SPC</u>	<u>PROT AREA</u>	<u>CONCRETE</u>
4422	Webscapes Libra (2m) Activity Net	10' x 10'	22' x 22'	4.0 cu. yds.
4424	Webscapes Pegasus (4m) Activity Net	18' x 18'	31' x 31'	4.0 cu. yds.
4426	Webscapes Aquarius (6m) Activity Net	26' x 26'	39' x 39'	11.13 cu. yds.

**DESCRIPTION**

Webscapes Activity Nets are freestanding climbers comprising interlinked nylon ropes anchored to the ground in four (4) corners and ascending to the apex of a central mast.

**MATERIALS**

**Activity Nets:** The nets shall be constructed of 18mm diameter, steel reinforced nylon braided rope with heavy duty aluminum joints hydraulically pressed into position (with a bursting strength in excess of 2.5 metric tons), a CNC machined top cap, galvanized foundation steelwork, and a central mast of 5" O.D., 11 ga., stainless steel tube. The nylon rope is specially woven to produce a durable yet extremely soft covering. The rope shall have a minimum safe working load of 9000 kg and shall comply with ISO R114/DS2114 and ISO 2232.

**Fasteners:** The assembly shall contain Fastener Style A hardware.

**Finishes:** The nylon braided rope shall be available in a variety of colors.

Consult Miracle's "Glossary of Technical Data for Materials, Processes and Finishes" for specifications of underlined items.



## Mini City - Community Helper, Truck, Playhouse, Silly Tree, Garden Crawl Tunnel, Sensory Garden Wall (Double Sided), Traffic Light, Chattery

MR0880, MR0880BD  
Mini City Community Helpers

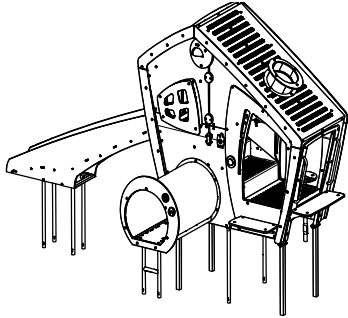

MR0881, MR0881BD  
Mini City Truck

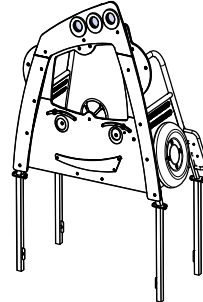

MR0882, MR0882BD  
Mini City Playhouse

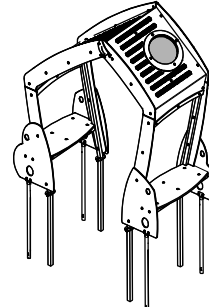

MR0883, MR0883BD  
Mini City Garden Crawl

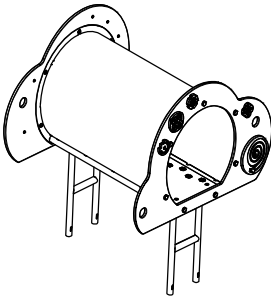

MR0884, MR0884BD  
Mini City Sensory Garden Wall Double Sided

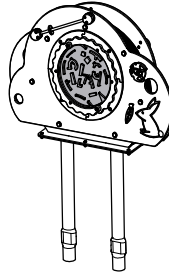

MR0885, MR0885BD  
Mini City Silly Tree

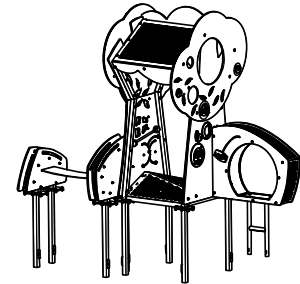

MR0886, MR0886BD  
Mini City Traffic Light



MR0887, MR0887BD  
Mini City Chattery

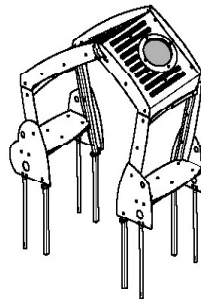

MR0888, MR0888BD  
Mini City Sensory Garden Wall Single Sided

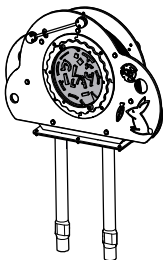

MR0889, MR0889BD  
Mini City Community Helpers w/o Crawl Tube

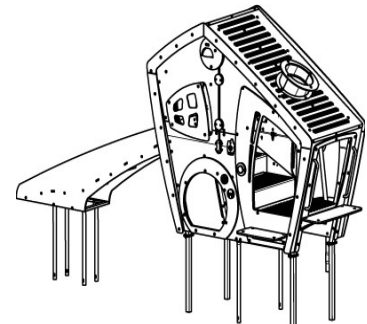

Consult Miracle's "Glossary of Technical Data for Materials, Processes and Finishes" for specifications of underlined items.

Mini City

MR0880, MR0881, MR0881BD, MR0882, MR0883, MR0884, MR0885, MR0886, MR0887, MR0888, MR0889

## Mini City - Community Helper, Truck, Playhouse, Silly Tree, Garden Crawl Tunnel, Sensory Garden Wall (Double Sided), Traffic Light, Chatterry

<u>MODEL</u>	<u>PRODUCT</u>	<u>GROUND SPACE</u>	<u>CONCRETE</u>
MR0880	Mini City Community Helpers (In-Ground)	29'-0" x 23'-0"	1.10 cu. yds.
MR0880BD	Mini City Community Helpers (Bolt Down)	29'-0" x 23'-0"	1.10 cu. yds.
MR0881	Mini City Truck (In-Ground)	NA	0.24 cu. yds.
MR0881BD	Mini City Truck (Bolt Down)	NA	0.24 cu. yds.
MR0882	Mini City Playhouse (In-Ground)	14'-0" x 17'-0"	0.48 cu. yds.
MR0882BD	Mini City Playhouse (Bolt Down)	14'-0" x 17'-0"	0.48 cu. yds.
MR0883	Mini City Garden Crawl (In-Ground)	17'-0' x 17'-0'	0.06 cu. yds.
MR0883BD	Mini City Garden Crawl (Bolt Down)	17'-0' x 17'-0'	0.06 cu. yds.
MR0884	Mini City Sensory Garden Wall Double Sided (In-Ground)	NA	0.12 cu. yds.
MR0884BD	Mini City Sensory Garden Wall Double Sided (Bolt Down)	NA	0.12 cu. yds.
MR0885	Mini City Silly Tree (In-Ground)	23'-0" x 18'-0"	NA
MR0885BD	Mini City Silly Tree (Bolt Down)	23'-0" x 18'-0"	NA
MR0886	Mini City Traffic Light (In-Ground)	NA	0.13 cu. yds.
MR0886BD	Mini City Traffic Light (Bolt Down)	NA	0.13 cu. yds.
MR0887	Mini City Chatterry (In-Ground)	NA	0.48 cu. yds.
MR0887BD	Mini City Chatterry (Bolt Down)	NA	0.48 cu. yds.
MR0888	Mini City Sensory Garden Wall Single Sided (In-Ground)	NA	0.12 cu. yds.
MR0888BD	Mini City Sensory Garden Wall Single Sided (Bolt Down)	NA	0.12 cu. yds.
MR0889	Mini City Community Helpers w/o Crawl Tube (In-Ground)	29'-0" x 20'-0"	1.10 cu. yds.
MR0889BD	Mini City Community Helpers w/o Crawl Tube (Bolt Down)	29'-0" x 20'-0"	1.10 cu. yds.

**DESCRIPTION**

The Mini City Playhouses are designed to be enjoyed by children of all abilities, including autism, developmental delays and those that use mobility devices. Children can use their imagination, improve strength, agility and mobility.

**MATERIALS**

**Steel Frame:** Shall be constructed from 2" square tubing, 16-gage galvanized steel tubing, 1/4" steel plates.

**Steel Frame:** Shall be constructed from 12-gage and 14-gage galvanized steel.  
**(Sensory Garden Wall, Traffic Light)**

**Steel Roof/End Walls:** Shall be constructed from 12-gage galvanized steel plate.

**Stairs:** Shall be constructed from 12-gage steel coated with durable, thermoplastic coating.

**Deck Platform:** Shall be constructed from 12-gage steel coated with durable, thermoplastic coating.

Consult Miracle's "Glossary of Technical Data for Materials, Processes and Finishes" for specifications of underlined items.

## Mini City - Community Helper, Truck, Playhouse, Silly Tree, Garden Crawl Tunnel, Sensory Garden Wall (Double Sided), Traffic Light, Chatterry

### MATERIALS cont.

<b>Rope:</b>	Shall be 16mm rope with aluminum connector.
<b>Steel Crawl Tube:</b>	Shall be constructed from 14-gage galvanized steel, 8-gage galvanized steel, <u>1-1/4" pipe</u> , 13-gage galvanized steel tubing.
<b>Steel Climber:</b>	Shall be constructed from <u>1-1/2" pipe</u> , 13-gage galvanized steel tubing, 8-gage and 1/4" steel plate.
<b>Plastic Slide:</b>	Shall be <u>1/2" HDPE</u> bedway, <u>3/4" HDPE</u> sides.
<b>Plastic Steps/Seat:</b>	Shall be <u>3/4" textured HDPE</u> .
<b>Plastic Walls/Ends/ Panels:</b>	Shall be <u>3/4" HDPE</u> .
<b>Plastic Tire:</b>	Shall be rotationally molded LLDPE.
<b>Skylight: (Chatterry)</b>	Shall be 1/4" <u>Koda.XT</u> .
<b>Skylight: (Playhouse, Chatterry)</b>	Shall be 3/16" screen printed Lexan.
<b>Castings:</b>	Shall be 319 aluminum.
<b>Finishes:</b>	Finishes shall be in <u>Mira-Cote</u> .
<b>Fasteners:</b>	All fastening hardware shall be <u>Fastener Style A</u> .
<b>Shelves:</b>	Shall be constructed from 12-gage steel.
<b>Graphic Panels:</b>	Shall be 1/4" <u>fiberglass</u> signs.
<b>Dog Door/Belt Bridge:</b>	Shall be 3/8" <u>Flexthead</u> .
<b>Colored Lenses:</b>	Shall be 1/8" acrylic colored panels with 3/16" Lexan covers.

Consult Miracle's "Glossary of Technical Data for Materials, Processes and Finishes" for specifications of underlined items.

**Activity Panel Inserts**

ACTIVITY PANEL INSERTS

**714-715-201**  
Hypnotize Insert

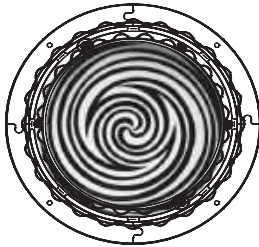

**714-715-202**  
Funhouse Insert

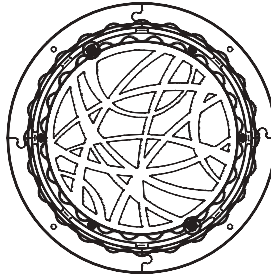

**714-715-203**  
Very Buried Insert

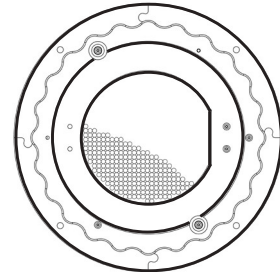

**714-715-204**  
A-maze-ing Insert

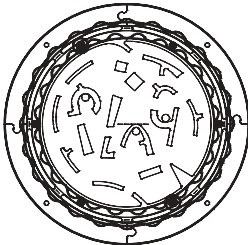

**714-715-205**  
Four-the-Win Insert

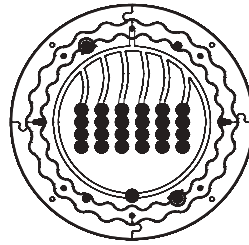

**714-715-206**  
Magical Music Insert

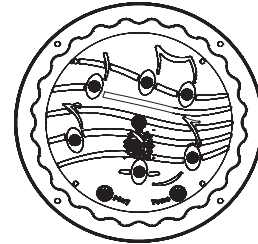

**714-715-207**  
Slide & Solve Insert

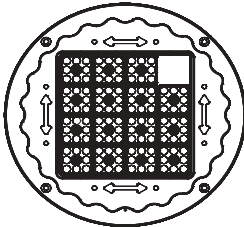

**714-715-208**  
3-Digit RG Timer Insert

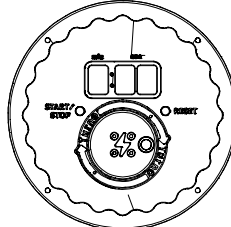

**714-715-216**  
Solar Explorer Panel Insert  
f/ KC/TC/TCX

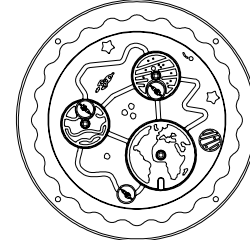

**714-715-209**  
Cam Chimes Panel Insert  
f/ KC/TC/TCX

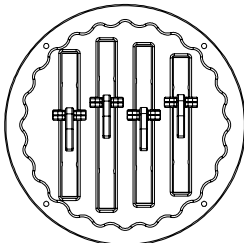

**714-715-212**  
3 Bell Panel Insert  
f/ KC/TC/TCX

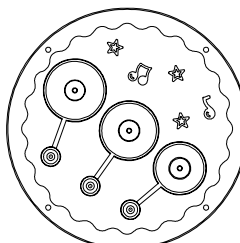

**714-715-213**  
Bongo Panel Insert  
f/ KC/TC/TCX

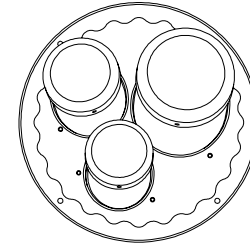

Consult Miracle's "Glossary of Technical Data for Materials, Processes & Finishes" for specifications of underlined items.

Activity Panel Inserts

714-715-201, 714-715-202, 714-715-203, 714-715-204, 714-715-205, 714-715-206, 714-715-207, 714-715-208, 714-715-209, 714-715-210, 714-715-211, 714-715-212, 714-715-213, 714-715-214, 714-715-215

# Activity Panel Inserts

**714-715-214**  
Tongue Drum Panel Insert  
f/ KC/TC/TCX

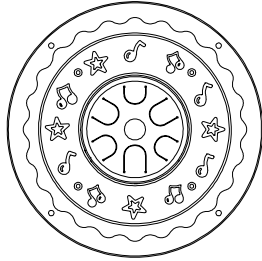

**714-715-211**  
Make It Rain Panel Insert  
f/ KC/TC/TCX

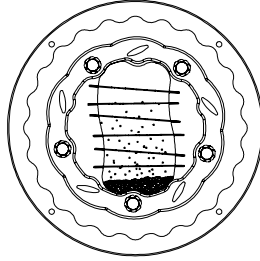

**714-715-215**  
Tumble Cog Panel Insert  
f/ KC/TC/TCX

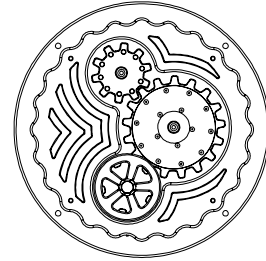

## DESCRIPTION

These representational activity panel inserts are designed to enhance imagination and creative play.

## MATERIALS

**Insert Panel Options:** Insert panel options shall be constructed from a combination of 1/2" thick high-density polyethylene, 3/4" thick high-density polyethylene, 3/16" thick polycarbonate, linear low-density polyethylene caps and stainless steel ball bearings.

714-715-201, 714-715-202, 714-715-203, 714-715-204, 714-715-205, 714-715-206, 714-715-207, 714-715-208, 714-715-216, 714-715-209, 714-715-212, 714-715-213, 714-715-214, 714-715-211, 714-715-215



18535 Old Statesville Rd., Suite C  
Cornelius, NC 28031

APS-Border8            8” Playground Border with spike  
Dimensions:            52” x 4” x 8”  
Spike:                    18” spike  
Manufacturing:        100% recycled, post-industrial HDPE, Blow Mold Construction  
Weight:                  10# with spike

APS-Border12         12” Playground Border with spike  
Dimensions:            52” x 4” x 12”  
Spike:                    28” spike  
Manufacturing:        100% recycled, post-industrial HDPE, Blow Mold Construction  
Weight:                  10# with spike

Both the 8” and 12” playground borders feature APS Exclusive “Surfacing Guide”



U.S. Patent D732,357



**model no:**

LTSG300D, LTSG301D, LTSG303D, LTSG304D, LTSG306D, LTSG307D, LTSG312D,  
LTSG313D, LTSG315D, LTSG316D, LTSG318D, LTSG319D,

MRS300D, MRS301D, MRS303D, MRS304D, MRS306D, MRS307D,  
MRS312D, MRS313D, MRS315D, MRS316D, MRS318D, MRS319D,

ZZSG300D, ZZSG301D, ZZSG303D, ZZSG304D, ZZSG306D, ZZSG307D, ZZSG312D,  
ZZSG313D, ZZSG315D, ZZSG316D, ZZSG318D, ZZSG319D

**WABASH VALLEY****SIGNATURE SERIES**

6' & 8' BENCH WITH & WITH OUT BACK - EXPANDED METAL  
& PERFORATED - PORTABLE, INGROUND & SURFACE MOUNT

© Wabash Valley Manufacturing, Inc.

**customer service:**

**ASSEMBLERS:** If you find any parts missing or damaged, or if you're having difficulty assembling your furniture/equipment, call us at:

• Before calling, have your product model number available.

1-800-253-8619 (Inside U.S.A.)

260-352-2102 (Outside U.S.A.)

Monday thru Friday,  
8:00 AM - 4:30 PM Eastern Time

(EXCEPT HOLIDAYS)

Any correspondence concerning our product should be sent directly to our Customer Service Manager at:

Wabash Valley Manufacturing, Inc.  
505 E. Main Street  
P.O.Box 5  
Silver Lake, IN 46982 U.S.A.  
FAX: 260-352-2160

**maintenance:**

Regular inspection and maintenance of all parts, and fasteners is necessary. Tighten all bolts and nuts. Inspect Tops, Seats, Legs, Braces and Fasteners periodically for wear or vandalism. Replace broken or worn parts immediately or take equipment out of service until repairs are made. Use genuine Wabash Valley replacement parts.

To restore plastisol coating to its luster after prolonged use, wash/rinse/dry and use Armor-All ® or similar quality vinyl protectant.

**KEEP THIS ASSEMBLY/SPECIFICATION SHEET FOR FUTURE REFERENCE.**

**specifications:**

**NOTE:** We reserve the right to change specifications without notice.

Heat fused poly-vinyl coating, finished on inner-metal structure, to an approximate 3/16" thickness. Framework assemblies are finished with powder coating; electrostatically applied and oven cured according to powder manufacturer's specifications. Fasteners are stainless steel to resist corrosion.

**BENCH FRAME:**

Main supports are constructed of 2 3/8" od x 12 gage structural steel tubing. Braces are 1" od x 15 gage structural steel tubing. Mounting brackets on legs are 1/4" x 2" steel flat bar or 10 gage sheet steel. Base plates are 1/4" plate steel.

**SEATS:**

Seat and back uses 3/4" #9 expanded steel mesh and 12 gage sheet steel for the perforated. Framing consists of die formed 10 gage mitered angles 3/4" x 1 3/4". Center brace and mounting brackets are 1/4" x 1 1/2" steel flat bar.

**GENERAL:**

6' bench ground space requirements are; inground and surface mount with out back is 10 3/8" x 72 3/8", with back is 19 5/8" x 72 3/8", portable with out back is 18 1/8" x 72 3/8", with back is 23 3/16" x 72 3/8". Seats are 10 3/8" wide x 72 3/8" long, 19" to top of seat and 31 3/4" to top of bench. Corner radius is 3" to the outside.

8' Bench ground space requirements are; inground and surface mount with out back is 10 3/8" x 96 3/8", with back is 19 5/8" x 96 3/8", portable with out back is 18 1/8" x 96 3/8", with back is 23 3/16" x 96 3/8". Seats are 10 3/8" wide x 96 3/8" long, 19" to top of seat and 31 3/4" to top of bench. Corner radius is 3" to the outside.

**parts identification:**

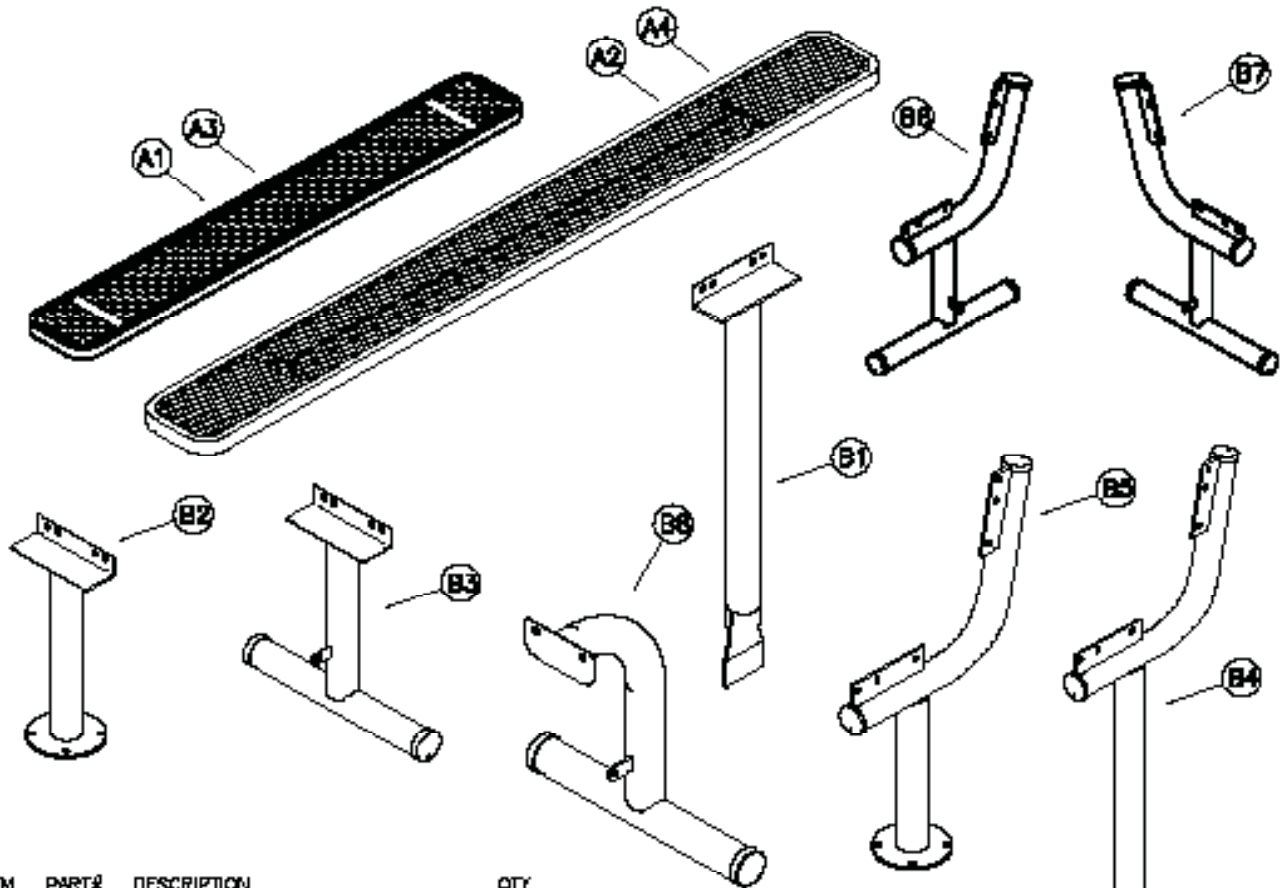

ITEM	PART#	DESCRIPTION	QTY
A1	7529R	6' EXPANDED METAL SEAT	1
A2	7527R	6' EXPANDED METAL SEAT	1
A3	7894	6' PERFORATED SEAT	1
A4	7892	6' PERFORATED SEAT	1
B1	7339	BENCH W/D BACK INGROUND LEG	2
B2	7340	BENCH W/D BACK SURFACE LEG	2
B3	7341	BENCH W/D BACK PORTABLE LEG	2
B4	7346	BENCH W/BACK INGROUND LEG	2
B5	7346	BENCH W/BACK SURFACE LEG	2
B6	7347	BENCH W/BACK PORTABLE RIGHT LEG	1
B7	7348	BENCH W/BACK PORTABLE LEFT LEG	1
B8	7072	B' RE/PLAYER PORTABLE LEG	2
C1	7388	BRACE	2
C2	7120	MOUNTING PLATE COVER (OPTIONAL)	2
C3	7073	B' RE/PLAYER BRACE	2

**hardware identification:**

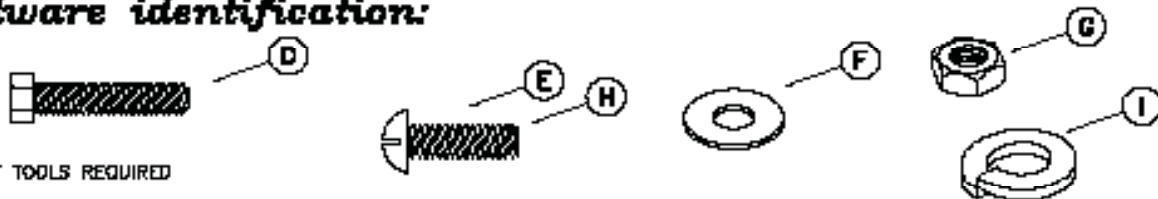

**ASSEMBLY TOOLS REQUIRED**

- 1 - REGULAR TIP SCREWDRIVER
- 2 - 1/2" WRENCHES
- 1 - 3' OR 6' LEVEL

**ITEMS INCLUDED IN HARDWARE PACKAGE #:**

ITEM	PART#	DESCRIPTION	21011 QTY	21012 QTY	21013 QTY	21014 QTY	21088 QTY	21076 QTY	21101 QTY
D	17011	5/16-18 x 1 1/2" HEX HEAD BOLT - SS	8	8	10	4	4	8	0
E	17088	5/16-18 x 1" TRUSS HEAD MACHINE SCREW - SS	2	0	2	0	0	0	0
F	17028	3/8" FLAT WASHER - SS	18	18	24	8	8	18	0
G	17032	5/16-18 HEX FINISH NUT - SS	8	8	12	4	4	8	0
H	17092	1/4-20 x 1" MACHINE SCREW - SS	0	0	0	0	0	0	2
I	17090	5/16" SPLIT LOCK WASHER - SS	8	8	12	4	4	8	0

**assembly procedures:** **IMPORTANT:** Assemblers should be reasonably skilled in the assembly of commercial grade/heavy duty fabricated steel equipment.

To ensure proper assembly, it is suggested that you take adequate time to locate and identify each part. To prevent scratching of the finished pieces, we recommend this unit to be assembled on a clean, flat, solid, surface with a drop cloth, allowing plenty of working room. Also please read the instructions and study the sketches very carefully. A little extra time spent before assembly will be well worth it in performing a complete, proper assembly. Please note that all parts have been pre-cut and pre-drilled.

During the assembly process leave all bolts and nuts "finger tight", until the entire unit is completely assembled. This allows room for movement to level or adjust all seats, tops, benches, framework and braces if necessary. **After final adjustment and leveling, permanently tighten all nuts, bolts and fasteners.**

76

**PORTABLE WITH BACK**

**STEP 1**

Invert the (A-) seat upside down on an elevated surface. Place edge of seat flush with surface. Attach both (B6) and (B7) right and left legs to the outer most part of the seat's mounting brackets, with the tab on each leg facing each other toward the center of the seat, see FIG. 1. Use two, per leg, (D) and (G) using two (F) and one (I) per (D).

**STEP 2**

Attach one end of the (C1) brace to tab on leg. Use one (E), (G), (I) and two (F) per (E). Attach opposite end of brace to the center brace on the seat. Use one (D), (G), (I) and two (F) per (D). Repeat STEP 2 for other end.

**STEP 3**

Rotate bench to the upright position. Attach the second seat (A1) or (A2) to the outer most part of the bench's back mounting bracket, see FIG. 2. Use two, per each side, (D) and (G) using two (F) and one (I) per each (D).

FIG. 1

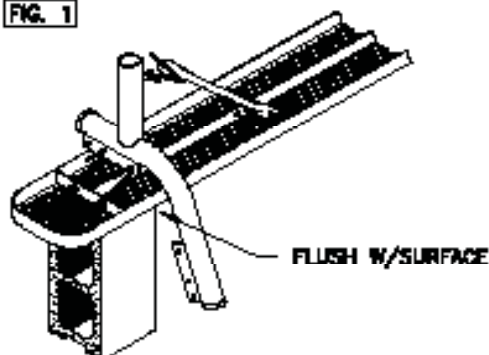
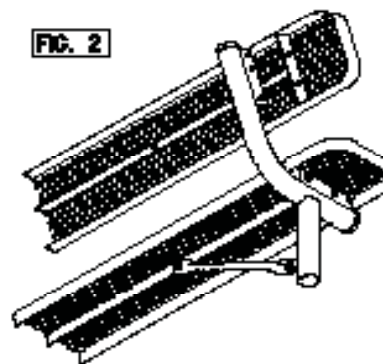

FIG. 2



**PORTABLE WITH OUT BACK**

**STEP 1**

Invert the (A-) seat upside down on a flat surface. Attach both (B3-8') or (B6-8' not shown) legs to the outer most part of the seat's mounting brackets, with the tab on each leg facing each other toward the center of the seat, see FIG. 3. Use two, per leg, (D) and (G) using two (F) and one (I) per (D).

**STEP 2**

Attach one end of the (C1-6') or (C3-8') brace to tab on leg. Use one (E), (G), (I) and two (F) per (E). Attach the opposite end of brace to the center brace on the seat. Use one (D), (G), (I) and two (F) per (D). Repeat STEP 2 for the other end.

**STEP 3**

Rotate bench to the upright position.

FIG. 3

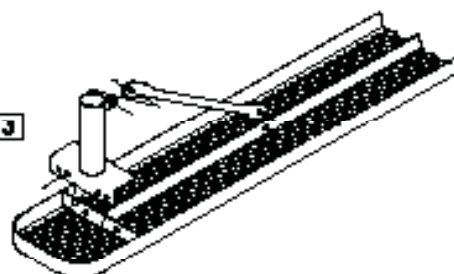

**installation:** **WARNING:** The proper installation for Wabash Valley products may depend upon many factors unique to the site, location, or use of a particular product. Consult with your contractor or other professional to determine your specific installation requirements.

**product dimensions:**

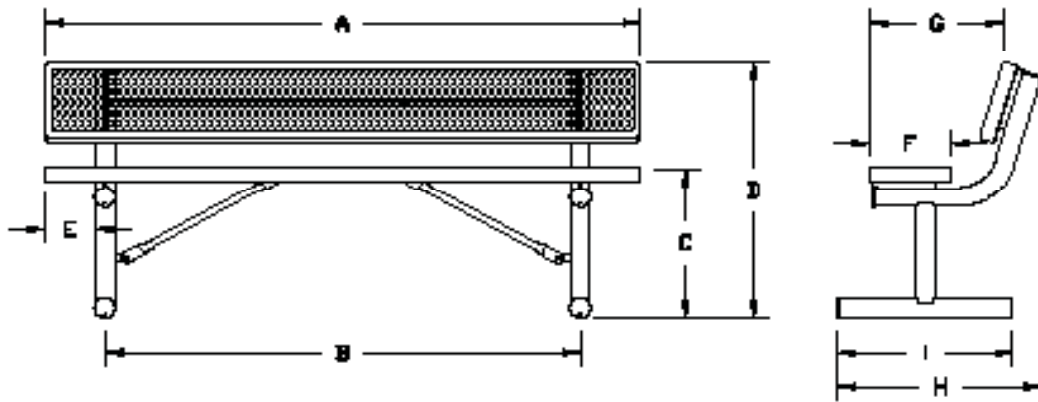

PORTABLE		A	B	C	D	E	F	G	H	I
B' W/D	BACK	72 3/8"	54 1/2"	19"	-	7 3/4"	10 3/8"	-	-	18 1/8"
B' W/	BACK	72 3/8"	57 3/8"	19"	31 3/4"	8 5/16"	10 3/8"	15"	23 3/16"	18 1/8"
B' W/D	BACK	88 3/8"	62 1/2"	19"	-	15 3/4"	10 3/8"	-	-	18 1/8"
B' W/	BACK	88 3/8"	65 3/8"	19"	31 3/4"	14 5/16"	10 3/8"	15"	23 3/16"	18 1/8"

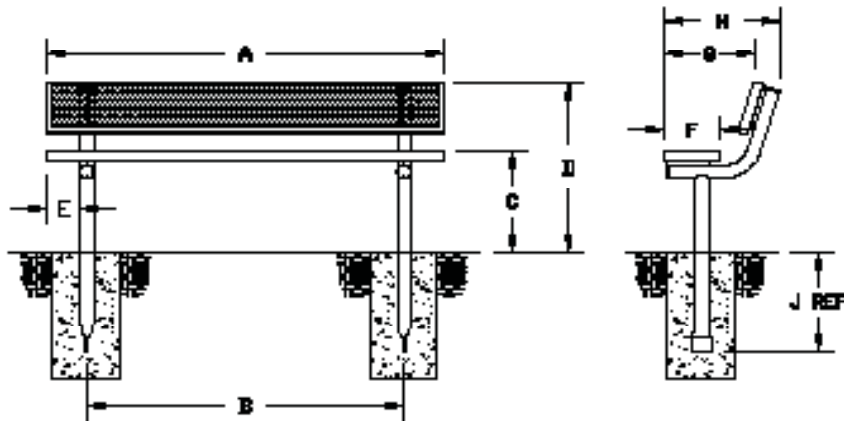

INGROUND		A	B	C	D	E	F	G	H	J
B' W/D	BACK	72 3/8"	54 1/2"	19"	-	7 3/4"	10 3/8"	-	-	18 1/8"
B' W/	BACK	72 3/8"	57 3/8"	19"	31 3/4"	8 5/16"	10 3/8"	15"	19 5/8"	20 1/8"
B' W/D	BACK	88 3/8"	62 1/2"	19"	-	16 3/4"	10 3/8"	-	-	18 1/8"
B' W/	BACK	88 3/8"	65 3/8"	19"	31 3/4"	14 5/16"	10 3/8"	15"	19 5/8"	20 1/8"

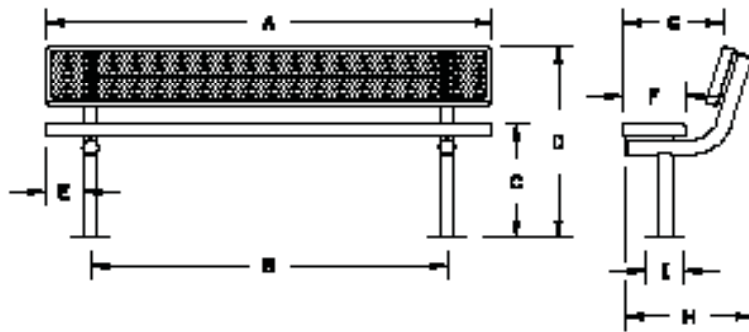

SURFACE		A	B	C	D	E	F	G	H	I
B' W/D	BACK	72 3/8"	54 1/2"	19"	-	7 3/4"	10 3/8"	-	-	8"
B' W/	BACK	72 3/8"	57 3/8"	19"	31 3/4"	8 5/16"	10 3/8"	15"	19 5/8"	8"
B' W/D	BACK	88 3/8"	62 1/2"	19"	-	15 3/4"	10 3/8"	-	-	8"
B' W/	BACK	88 3/8"	65 3/8"	19"	31 3/4"	14 5/16"	10 3/8"	15"	19 5/8"	8"

## assembly procedures, cont'd:

### SURFACE MOUNT WITH BACK

#### STEP 1

Invert the (A-) seat upside down on an elevated surface. Place edge of seat flush with surface. Attach both (B5) legs to the outer most part of the seat's mounting brackets, see FIG. 4. Use two, per leg, (D) and (G) using two (F) and one (I) per (D).

#### STEP 2

Reinvert bench to its top side up position. Attach the second seat (A-) to the outer most part of the bench's back mounting bracket, see FIG. 5. Use two, per each side, (D) and (G) using two (F) and one (I) per each (D).

#### STEP 3

Prepare and place the foundations securement hardware in its chosen location. A detailed description of where the hole locations should be placed is shown on page 4.

When the foundations securement hardware has been installed, place the unit in its new location and secure to the foundation.

If mounting plate covers (C2) are used place halves around legs and secure with 2 (H) screws, see FIG. 12. Draw to a snug fit being careful not to over tighten.

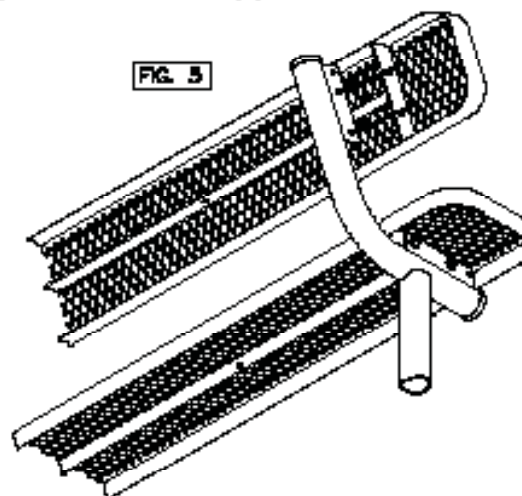
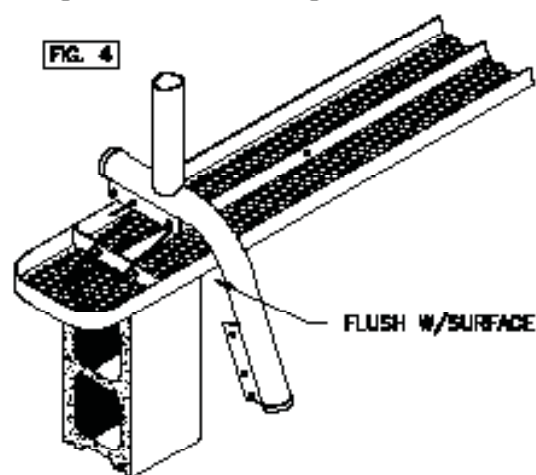

### SURFACE MOUNT WITH OUT BACK

#### STEP 1

Invert the (A-) seat upside down on a flat surface. Attach both (B2) legs to the outer most part of the seat's brackets, see FIG. 6. Use two, per leg, (D) and (G) using two (F) and one (I) per (D).

#### STEP 2

Reinvert bench to its top side up position.

#### STEP 3

Prepare and place the foundations securement hardware in its chosen location. A detailed description of where the hole locations should be placed is shown on page 4.

When the foundations securement hardware has been installed, place the unit in its new location and secure to the foundation.

If mounting plate covers (C2) are used place halves around legs and secure with 2 (H) screws, see FIG. 12. Draw to a snug fit being careful not to over tighten.

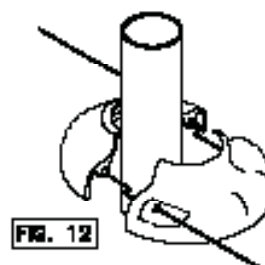
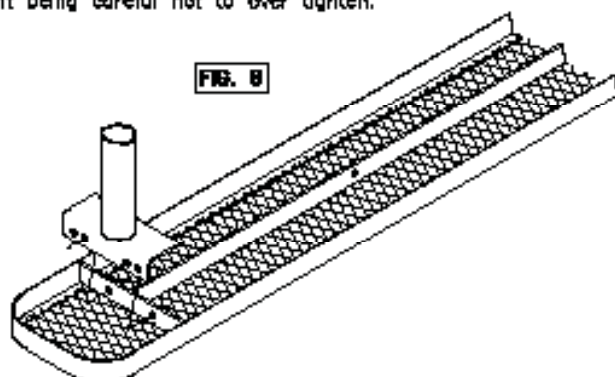

## assembly procedures, cont'd:

### INGROUND WITH BACK

#### STEP 1

Invert the (A-) seat upside down on an elevated surface. Place edge of seat flush with surface. Attach both (B4) legs to the outer-most part of the seat's mounting brackets, see FIG. 7. Use two, per leg, (D) and (G) using two (F) and one (I) per (D).

#### STEP 2

Prepare two foundation holes as shown in FIG. 8. The distance of holes, center to center, are shown in a diagram on page 4. Reinvert the bench to its' top side up position and place the legs in the footing holes, see FIG. 8.

Before pouring concrete, make sure the bench is level horizontally as well as vertically and holds 19" to the top of the bench. Pour concrete to form the footings and let cure for 48 hours.

#### STEP 3

Attach the second bench (A1) or (A2) to the outer most part of the bench's back mounting bracket, see FIG. 9. Use two, per each side, (D) and (G) using two (F) and one (I) per each (D).

If mounting plate covers (C2) are used place halves around legs and secure with 2 (H) screws, see FIG. 12. Draw to a snug fit being careful not to over tighten.

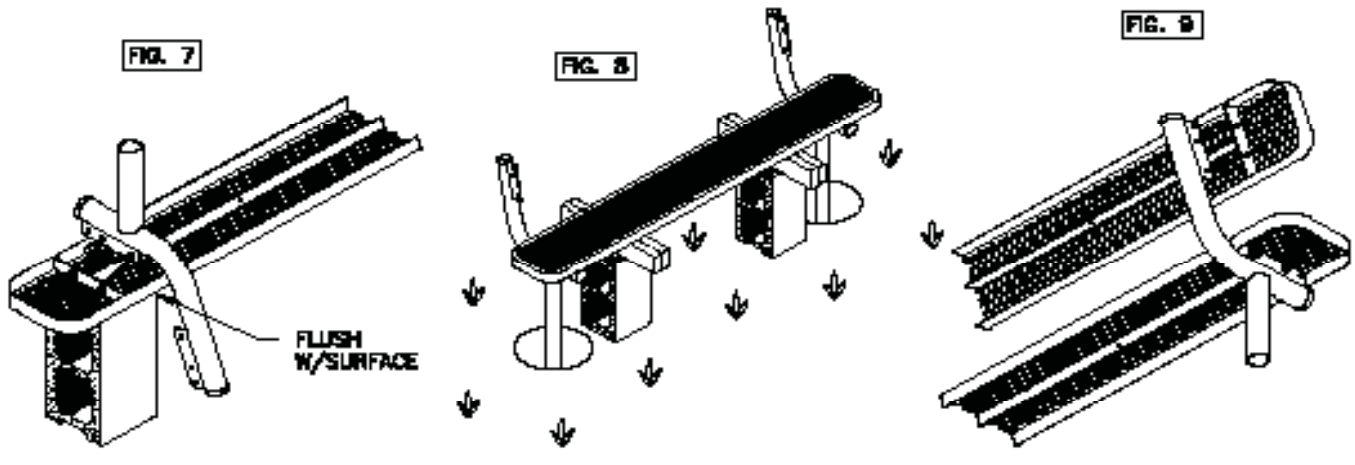

### INGROUND WITH OUT BACK

#### STEP 1

Invert the (A-) seat upside down on a flat surface. Attach both (B1) legs to the outer most part of the seat's mounting brackets, see FIG. 10. Use two, per leg, (D) and (G) using two (F) and one (I) per (D).

#### STEP 2

Prepare two foundation holes as shown in FIG. 11. The distance of the holes, center to center, are shown in a diagram on page 4. Reinvert the bench to its' top side up position and place the legs in the footing holes. Block the bench as shown in FIG. 11.

Before pouring concrete, make sure the bench is level horizontally as well as vertically and holds 19" to the top of the bench. Pour concrete to form the footings and let cure for 48 hours.

If mounting plate covers (C2) are used place halves around legs and secure with 2 (H) screws, see FIG. 12. Draw to a snug fit being careful not to over tighten.

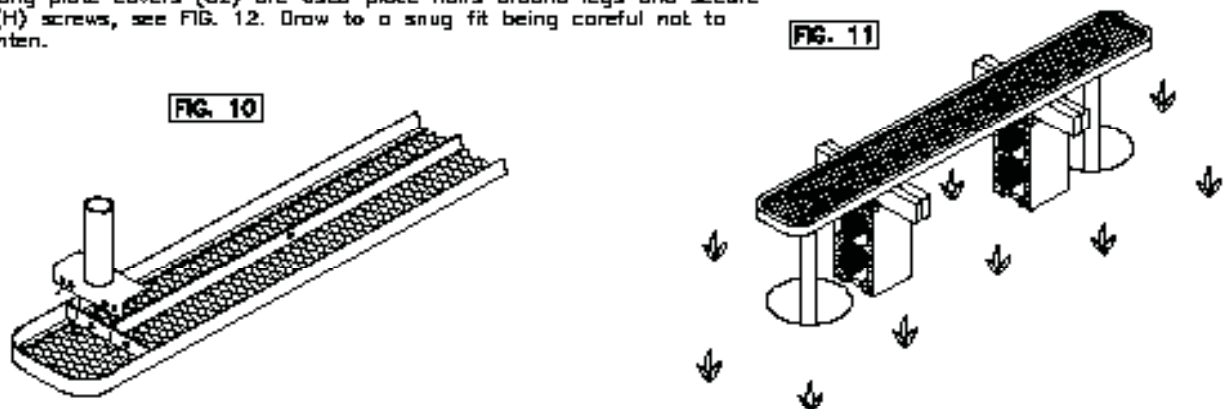

# Harding Park Miracle Recreation Proposal B.3

REVISED FOR BROWN DECKS  
DATE: 11/13/2025



# Harding Park Miracle Recreation Proposal B.3

REVISED FOR BROWN DECKS  
DATE: 11/13/2025



# Harding Park Miracle Recreation Proposal B.3

REVISED FOR BROWN DECKS  
DATE: 11/13/2025



# Harding Park Miracle Recreation Proposal B.3

REVISED FOR BROWN DECKS  
DATE: 11/13/2025



# Harding Park Miracle Recreation Proposal B.3

REVISED FOR BROWN DECKS  
DATE: 11/13/2025

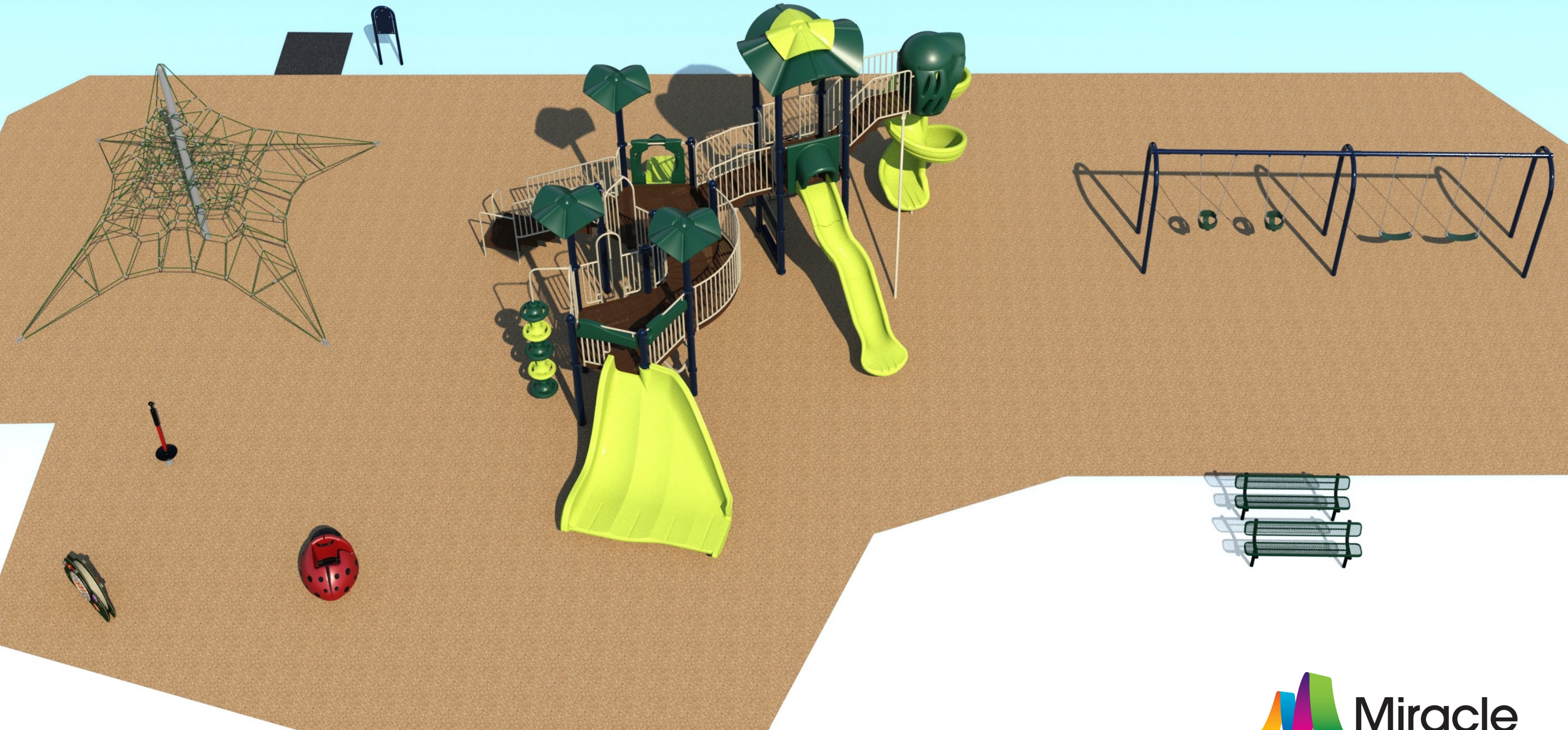

## Harding Playground Survey

During a playground renovation an important step for the Parks and Recreation Department is to receive community feedback about the design of the new playground equipment. For the Harding Park playground it was determined that there wasn't enough physical space or parking access to do an onsite citizen forum so commentary would need to be collected by an alternative method. After considering options, an electronic survey that could be shared and accessed by multiple methods was chosen as the channel for feedback.

Information about the survey availability was shared via signs with QR codes placed at Harding Park, emails to citizens in the Parks and Recreation database and information posted on the Town's website. Responses were collected from 10/22/2025 through 11/4/2025 via a Survey Monkey survey.

The survey included three questions: a choice between two finalist designs and two open-ended questions (*What is your favorite playground feature?* and *Additional comments or feedback*). There were 189 respondents total with 173 choosing between Option A and Option B for the design. Option B was the most popular with 80.5% (139) versus Option A with 19.65% (34). For the open-ended questions there were 153 comments to the first question and 82 to the second question.

Among the open comments the most prevalent themes were:

Net Climber (or variant on this name)	72
Swings	27
Slides	21
Music feature (or variant on this name)	14

Additional mentions:

*The dinosaur will be missed*

*Like the lady bug and new spinner feature (maybe more than one)*

*Additional shade (natural and/or artificial) and keep the picnic tables (we were already planning to keep the picnic tables they just did not appear in the images shared)*

*Concerns about safety – children running into street, enclosed features creating spaces for undesirable behaviors, equipment safety*

With the overwhelming response for Option B the department proceeded with negotiating with the vendor upon a final design incorporating the popular suggestions that were practical within the space and budget for this project. Among the more significant adjustments was including a musical feature similar to what was popular from Option A.



**Agenda Item:** Application for Alteration to an Existing Structure, ARB #25-005

**Meeting Date:** January 7, 2026

**Category:** Public Hearings

**Prepared by:** Angelina Jones, Lead Planner / Design and Development

**Description:**

This application proposes to remove the vertical portion of the metal standing seam roof and replace the material with an EIFS sign band. This space already serves as a sign band as signs are installed on raceways attached to the standing seam metal. The applicant also proposes to paint the remaining portions of the roof black. For additional information, please see the attached staff report.

**Background/Timing Impact:**

The property at 300 Elden Street features an approximately 2.47-acre commercial shopping center. The site is improved with a strip mall-style shopping center featuring multiple bays framed by brick piers periodically accented with decorative turrets. The central turret features a clock. The roof for the center is a variation of a mansard clad in standing seam metal painted dark green. The vertical element of the roof is designed to feature shop signage. For additional background information and case history, please see the attached staff report.

**Fiscal Impact:**

N/A

**Legal Impact:**

N/A

**Staff Recommendation/Next Steps:**

Staff is withholding a recommendation pending discussion by the board at the work session.

**Attachments:**

1. Staff Report
2. Materials

## STAFF REPORT

**Agenda Item:** ARB #25-005; Alteration to an Existing Structure; Fairfax County Tax Map 0171 02 0025B1, 300 Elden Street

**Meeting Date:** January 7, 2026

**Staff Contact:** Angelina R. Jones, Lead Planner – Development & Design

**Summary Information:**

Proposed Modification	Alterations including recladding a portion of the existing shopping center in a new material		
Address	300 Elden St, Herndon, VA 20170		
Fairfax County Tax Map Number	0171 02 0025B1		
Owners	Tom Donaldson		
Applicant	David Bruhnke		
Business/Organization	F and M Centre		
Property Use	Commercial		
Zoning District	CS, Commercial Services District		
HDO Designation	N/A		
Adjacent Zoning	<p><b>North:</b> RTC - Residential Townhouse Cluster District      <b>East:</b> CO, Commercial Office District</p> <p><b>South:</b> CS - Commercial Services District      <b>West:</b> PD-B - Planned Development - Business</p>		
Building Type(s)	Shopping Center	<b>Date of Construction:</b>	c. 1985
Architectural Style(s)	Post-Modern		
Exterior Material(s)	Brick, Standing seam metal roof/cladding		
Neighborhood Design Profile	Mix of commercial with multi-family residential		
Comprehensive Plan Land Use Designation	Business Corridor		

**Location Map:**

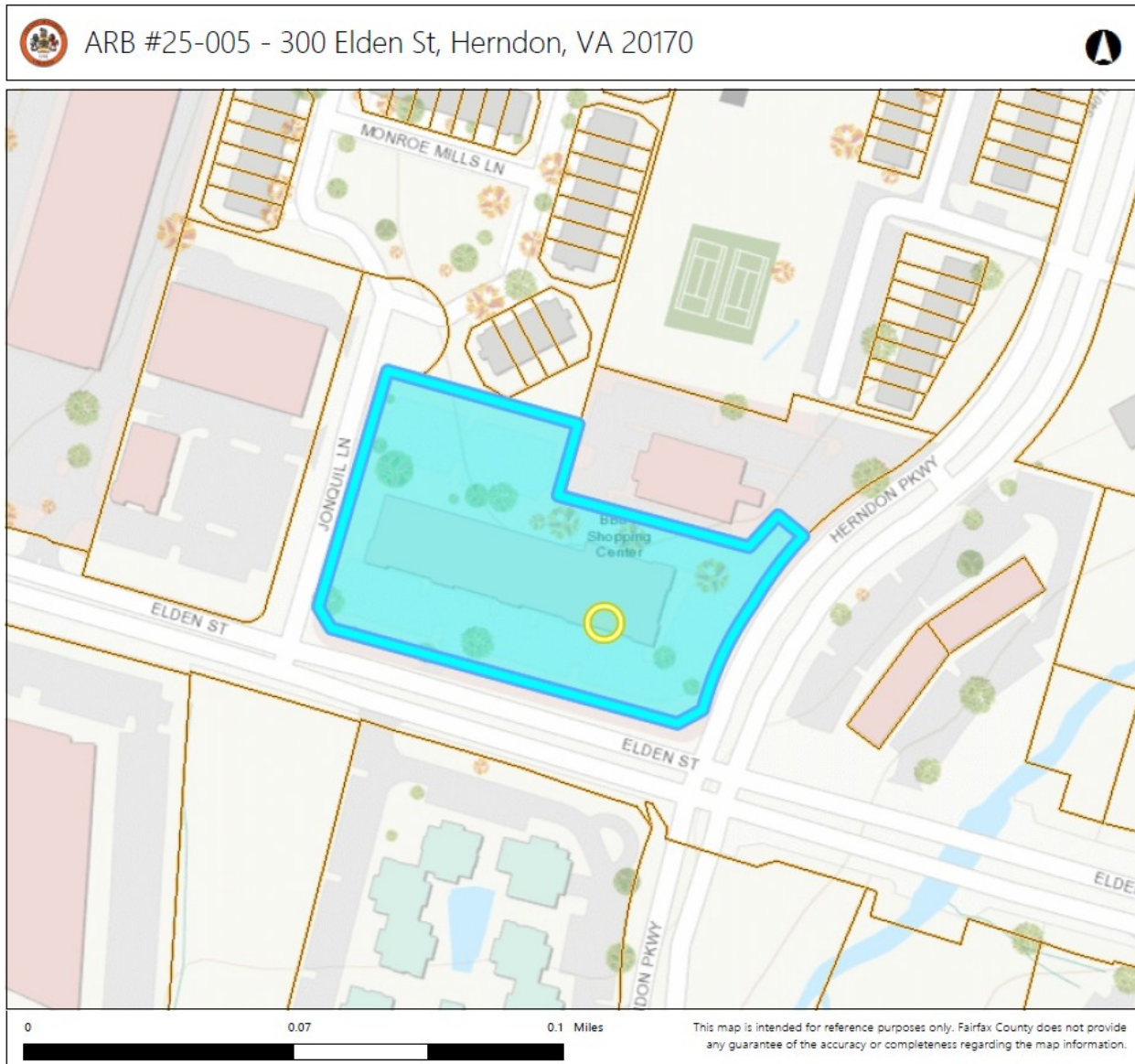

**Background Information:**

Property Description

The property at 300 Elden Street features an approximately 2.47-acre commercial shopping center. The site is improved with a strip mall style shopping center featuring multiple bays framed by brick piers periodically accented with decorative turrets. The central turret features a clock. The roof for the center is a variation of a mansard clad in standing seam metal painted dark green. The vertical element of the roof is designed to

feature shop signage (*Figure 1*). A bank building of the same general design stands to the north of the shopping center on an adjacent parcel (*Figures 2 and 3*).



*Figure 1: Central clock and signage at 300 Elden Street. Source: Google Maps, August 2019*



Figure 2: 300 Elden Street with bank building at 230 Herndon Parkway in the background. Source: Google Maps, August 2019



Figure 3: Bank building at 230 Herndon Parkway immediately adjacent to 300 Elden Street. Source: Google Maps, August 2019

### Applicable Land Use and Case History

There have been no recent applications for alterations to the shopping center at 300 Elden Street other than for businesses seeking to install signage.

While no two properties within the Architectural Control District are alike and therefore previous cases at other properties do not set precedent, knowledge of similar types of projects previously heard by the ARB provide useful context for evaluation. Related cases include the following:

- ARB #19-09 – On March 20, 2019, the ARB voted to approve an application for alterations at the commercial property, a hotel, at 533 Herndon Parkway including alterations to the materials of the exterior storefront. These modifications included a new metal canopy covering an aluminum storefront system clad in metal paneling and faux wood.
- ARB #23-007 – On April 19, 2023, the ARB approved an application to paint the apartment buildings at 315 Elden Street. The change to the façade included painting previously unpainted elements including masonry clad walls.
- ARB #25-002 – The ARB voted to approve painting the previously unpainted masonry of the commercial building at 1051 Elden Street on May 21, 2025. The adopted resolution was conditioned to require that exterior grade, mineral-based paint in a matte finish be used.

**Case Details & Proposal:**

This application proposes to remove the vertical portion of the metal standing seam roof and replace the material with an EIFS sign band. This space already serves as a sign band as signs are installed on raceways attached to the standing seam metal. The applicant also proposes to paint the remaining portions of the roof black. The applicant has not communicated whether a similar modification is planned to the exterior of the bank building at 230 Herndon Parkway. Note that the owners of record between these two properties differ and therefore the applicant may be unaware of work intended for the bank building. In the absence of additional information, the ARB should evaluate the proposed alterations at 300 Elden in isolation and in the context of existing conditions.

**Staff Analysis:**

Zoning Ordinance Compliance

- Town Code of Ordinances, Section 58-96 – Design criteria
  1. Staff has found that the proposed alteration meets the applicable standards and requirements of the Town of Herndon Zoning Ordinance.
  2. With the findings expressed below, staff assert that the proposed alteration generally does not comply with the applicable design criteria within the Town’s Architectural Control District as specified in Section 58-96 of the Town Code of Ordinances. Staff have used these design criteria to evaluate the proposed design changes, summarized in the following table:

<b>Town Code of Ordinances, Section 58-96 – Design criteria</b>	
The board of architectural review and, on appeal, the town council shall use the following standards and criteria in considering applications filed under this article:	
1) Whether or not the proposed architectural design is suitable for a good suburban community in terms of external architectural features, including signs subject to public view, general design and arrangement, texture, color, line, mass, dimension, material and lighting.	The commercial building at 300 Elden Street was designed in the post-modern style and is intentionally coordinated with the adjacent bank building. The cohesive design between the shopping center and the bank is an intentional strategy for effective placemaking. The proposed alteration will change the overall character of the shopping center and sever the intended visual connection to the bank building. Therefore, the

	proposed change is not suitable for a good suburban community.
2) Whether or not the proposed structure, building or improvement is compatible with existing well-designed structures, acceptable to the board, in the vicinity and in the town as a whole.	As stated above, the shopping center is intended to be visually cohesive with the adjacent bank, therefore the proposed alteration to 300 Elden will decrease its compatibility with this neighboring building. The applicant has provided no indication that similar alterations are proposed for the bank at the neighboring property.
3) Whether or not, and to what extent, the proposed structure, building or improvement would promote the general welfare and protect the public health, safety and morals by tending to maintain or augment the town's tax base as a whole, generating business activity, maintaining and creating employment opportunity, preserving historical sites and structures and making the town a more attractive and desirable place in which to live.	The proposal will remove a portion of the standing seam metal roof from the property at 300 Elden Street and replace this material with EIFS. EIFS is a less durable material than standing seam metal. Furthermore, removing a portion of the mansard roof cladding negatively impacts the overall architectural character of the building and diminishes its legibility as a post-modern design.
4) Whether or not proposed freestanding buildings use the same or architecturally harmonious materials, color, texture and treatment for all exterior walls; and in the case of partially freestanding buildings, whether or not the same or architecturally harmonious materials, color, texture and treatment are used on all portions of all exterior walls exposed to public view.	The proposed modification changes the mansard roof design by removing the extant roofing material and converting it to an EIFS covered wall. Although the design change is not inherently unharmonious, it is less harmonious than the current standing seam metal roofing treatment.
5) Whether or not the combination of architectural elements proposed	As stated above, the proposed modification removes a highly durable

<p>for a structure, building or improvement, in terms of design, line, mass, dimension, color, material, texture, lighting, landscaping and roofline and height conform to accepted architectural principles for permanent buildings as contrasted with engineering standards designed to satisfy safety requirements only; and exhibit external characteristics of demonstrated architecture and aesthetic durability.</p>	<p>material, standing seam metal, and replaces it with EIFS, which is much less durable. Note that painting the existing standing seam metal roof a new color will not adversely impact the durability of this feature. However, staff are requesting paint technical information to verify that it is appropriate for exterior use.</p>
<p>6) Whether or not, in terms of design, material, texture, color, lighting, landscaping, dimension, line, mass or roof line and height, the proposed structure, building or improvement is designed to serve primarily as an advertisement or commercial display, exhibits exterior characteristics likely to deteriorate rapidly, would be of temporary or short-term architectural or aesthetic acceptability, would be plainly offensive to human sensibilities or would otherwise constitute a reasonable foreseeable detriment to the community.</p>	<p>As noted above, the proposed change to create an EIFS sign band by replacing the existing standing seam metal introduces a less durable material that is likely to deteriorate over time.</p>

3. Staff are requesting the following information and materials from the applicant:
  - a. Clarification as to whether the applicant has knowledge of a similar modification being proposed for the bank at 230 Herndon Parkway.

**ARB Alternatives:**

The following alternatives are available to the ARB for its decision on #25-005.

1. Approval as proposed

2. Approval with conditions
3. Denial on specific stated grounds
4. Continuance of the application to a future public hearing

**Staff Recommendation:**

Staff is withholding a recommendation pending discussion by the board at the work session.

December 10, 2025

Angelina R. Jones  
Lead Planner - Design & Development  
Town of Herndon, VA

Angelina,

We are the architects working with ownership at 300 Elden Shopping Center to update the exterior finishes.

Attached please find the written permission from the property owner authorizing the property modification activity. (Owner Letter-300 Elden-ARB Herndon.pdf)

Attached are images of the existing building showing the before and after of the renovations. (ARB Exhibits - 300 Elden 2025-12-01.pdf) The owner is looking to refresh the color of the standing seam roof as well as reduce the amount of standing seam roof shown behind the sign band of the building. We are proposing to install thin stucco system over cement board in a light color to match the existing EIFS system at the towers of the building.

Specifications for the paint (SW Bond-Plex.pdf) and stucco system (Dryvit System-cementboardm specification.pdf) are attached for your use and information.

Please review and let us know if there is anything else required to complete the process. If you have any questions, please let me know.

Sincerely,

David Bruhnke  
*Senior Director, Special Projects*  
The M Group Design, Inc., A Virginia Corporation



300 Elden Street | 250267

ARB review | 2025.12.01

Looking West | BEFORE





---

300 Elden Street | 250267

---

ARB review | 2025.12.01

---

Looking West | AFTER





300 Elden Street | 250267

ARB review | 2025.12.01

Looking East | BEFORE





---

300 Elden Street | 250267

---

ARB review | 2025.12.01

---

Looking East | AFTER



# **CEMENT BOARD MD FINISH SYSTEM™**



**DS191**

**An Exterior Finish System Applied Over Exterior Cement Board  
With A Water-Resistive Barrier And Moisture Drainage**

## **Cement Board MD Finish System Specifications**

**DRYVIT SYSTEMS, INC.**  
**MANUFACTURER'S SPECIFICATION**  
**CSI MASTERFORMAT SECTION 07 24 23**  
**CEMENT BOARD MD FINISH SYSTEM**

**PART I - GENERAL****1.01 SUMMARY:**

This document is intended to be used in preparing specifications for projects utilizing Cement Board MD Finish System by Dryvit. For complete product description and usage refer to:

- A. Dryvit Cement Board MD Data Sheet, [DS480](#)
- B. Dryvit Cement Board MD Installation Details, [DS190](#)

**1.02 RELATED SECTIONS**

- A. Project Meetings – Section 01 31 19
- B. Cold-Formed Metal Framing – Section 05 40 00
- C. Wood Framing – Section 06 11 00
- D. Flashing and Sheet Metal – Section 07 60 00
- E. Joint Protection – Section 07 90 00

**1.03 REFERENCES**

- A. AC59 Acceptance Criteria for Direct-Applied Exterior Finish Systems.
- B. AC148 Acceptance Criteria for Flashing Materials.
- C. ASTM B 117 (Federal Test Standard 141A Method 6061) Test Method of Salt Spray (Fog) Testing.
- D. ASTM C 79 Specification for Gypsum Sheathing Board.
- E. ASTM C 150 Specification for Portland Cement.
- F. ASTM C 297 Test Method for Tensile Strength of Flat Sandwich Constructions in Flatwise Plane.
- G. ASTM C 1177 Specification for Glass Mat Gypsum Substrate for Use as Sheathing.
- H. ASTM C 1325 Standard Specification for non-asbestos fiber-mat reinforced cementitious backer units.
- I. ASTM C 1516 Standard Practice for Application of Direct-Applied Exterior Finish Systems.
- J. ASTM D 968 (Federal Test Standard 141A Method 6191) Test Method for Abrasion Resistance of Organic Coatings by Falling Abrasive.
- K. ASTM D 2898 Standard Test Method for Accelerated Weathering of Fire-Retardant-Treated Wood for Fire Testing
- L. ASTM D 3273 Test Method for Resistance to Growth of Mold on Surfaces.
- M. ASTM E 84 Test Method for Surface Burning Characteristics of Building Materials.
- N. ASTM E 96 Test Methods for Water Vapor Transmission of Materials.
- O. ASTM G 23 (Federal Test Standard 141A Method 6151) Recommended Practice for Operating Exposure Apparatus (Carbon-Arc Type) With and Without Water, for Exposure of Nonmetallic Materials.

**1.04 SUBMITTALS**

- A. Submittal requirements by the contractor are to be indicated in the construction documents as required, including:
  - 1. Product literature, samples or mock-up.
  - 2. Finish sample indicating color and texture for approval by architect/owner.

**1.05 DESCRIPTION**

- A. Cement Board MD Finish System consisting of Dryvit base coat with reinforcing mesh, and finish applied over an exterior cement board that is installed over a code approved water-resistive barrier and approved drainage medium. The substrate, cement board, and water-resistive barrier (unless the water-resistive barrier is manufactured by Dryvit) are not part of the system.
  - 1. Design Requirements:
    - a. A sheathing board substrate installed over structural framing prior to installation of a code approved water-resistive barrier shall be one of the following:
      - 1) Exterior sheathing having a water-resistant core with fiberglass mat facers meeting ASTM C 1177.
      - 2) Exterior fiber reinforced cement meeting ASTM C 1325 or calcium silicate boards.
      - 3) APA Exterior or Exposure 1 Rated Plywood, Grade C-D or better, nominal 1/2 in (12.7 mm), minimum, installed with the C face out.
      - 4) APA Exterior or Exposure 1 Fire Retardant Treated (FRT) Plywood, Grade C-D or better, nominal 1/2 in (12.7 mm), minimum, installed with the C face out.
      - 5) APA Exposure 1 Rated Oriented Strand Board (OSB) nominal 1/2 in (12.7 mm), minimum. **NOTE: Applications over OSB sheathing requires a minimum of 2 coats of Backstop NT – Smooth or Spray. Backstop NT – Texture is not recommended for the field of wall application over OSB.**
    - b. The outer layer sheathing shall be exterior cement board meeting ASTM C 1325, minimum 1/2 in (12.7 mm).
    - c. The roofing materials shall be loaded onto the roof and interior wallboard stocked in the building prior to the installation of the Cement Board MD Finish System.

- d. Deflection of substrate systems shall not exceed L/360.
  - e. The slope of inclined surfaces shall not be less than 6:12 (27°) and the length shall not exceed 12 in (305 mm).
  - f. Expansion joints:
    - 1) Design and location of expansion/control joints in the substrate shall be determined by the project design professional and indicated on the contract documents. As a minimum, joints in Cement Board MD Finish System are required at the following locations:
      - a) Where expansion joints occur in the substrate system
      - b) Where building expansion joints occur
      - c) At floor lines in wood frame construction
      - d) Where Cement Board MD Finish System abuts dissimilar materials
      - e) Where the substrate changes
      - f) Where significant structural movement occurs such as changes in roofline, building shape or structural system
  - g. Control joints:
    - 1) Design and location of control joints shall be determined by the design professional. As a minimum, control joints shall be located at the following locations:
      - a) Corners of openings.
      - b) Such that wall lengths do not exceed 20 ft (6 m).
      - c) Length to width ratios of wall areas shall not exceed 2.5:1.
  - h. Sealants
    - 1) Use and location of sealants is the responsibility of the project designer and shall be indicated on the contract documents.
    - 2) Refer to Section 07 90 00.
    - 3) Refer to Dryvit publication [DS153](#) for a list of sealants that have been tested for compatibility with Dryvit products.
  - i. Vapor Retarders
    - 1) Use and location of vapor retarders within a wall assembly is the responsibility of the project designer and shall comply with local building code requirements. Type and location shall be noted on the contract documents. Vapor retarders may be inappropriate in certain climatic zones and can result in condensation within the wall assembly when incorrectly used. Refer to Dryvit publication [DS159](#) for additional information.
  - j. Flashing
    - 1) Flashing: shall be provided at all roof-wall intersections, windows, doors, chimneys, decks, balconies, and other areas as necessary to prevent water penetration behind Cement Board MD Finish System.
  - k. Site Coated EPS Shapes and Starter Boards: Shall be coated on site utilizing the same materials (EPS, base material mixture, reinforcing mesh, and finish) as specified for the project.
  - l. Machine Coated EPS Shapes and Starter Boards: Shall be supplied by a manufacturer that subscribes to the Dryvit third party certification and quality assurance program.
2. Performance Requirements: As a minimum, the Dryvit Cement Board MD Finish System products shall be tested as follows:
- a. ASTM B 117: Salt Spray Resistance – 300 hrs, no deleterious effects.
  - b. ASTM C 297 Bond Strength – Failure in the substrate.
  - c. ASTM D 968: Abrasion Resistance – 132 gal (500 L), no deleterious effects.
  - d. ASTM D 3273 Mildew/Fungus Resistance – Passed.
  - e. ASTM E 84 Flame Spread – Flame Spread Index less than 25, Smoke Developed less than 250.
  - f. ASTM E 96 Water Vapor Transmission – Vapor Permeable.
  - g. ASTM G 23 Accelerated Weathering – 2000 hrs, Passed.

## 1.06 QUALITY ASSURANCE

### A. Qualifications:

- 1. Manufacturer: Shall be Dryvit Systems, Inc. or approved suppliers. All materials shall be obtained from Dryvit Systems, Inc. or its authorized distributors.
- 2. Material shall be manufactured at a facility covered by a current ISO 9001:2015 and ISO 14001:2015 certification. Certification of the facility shall be by a registrar accredited by the American National Standards Institute-Registrar Accreditation Board (ANSI-RAB).
- 3. Plastering Contractor:
  - a. Shall be knowledgeable in the proper installation of Cement Board MD Finish System components.
  - b. Shall have qualified and properly trained people to perform work.
  - c. Shall be licensed, bonded and insured.
  - d. Shall have experience in application of direct-applied exterior finish systems on projects of comparable scope.

4. Third Party Inspection
    - a. Owner's independent third-party inspection is recommended to verify installation according to code and contract documents. It is recommended that as a minimum, inspection items include installation of the water-resistive barrier, flashings and accessories, Cement Board MD Finish System materials and sealants. The intent is to verify that the installation has been performed in accordance with code requirements, contract requirements and this specification.
  5. Machine Coated EPS Shapes and Starter Boards: Shall be supplied by a manufacturer that subscribes to the Dryvit third party certification and quality assurance program.
- B. Mock-Up
1. The contractor shall, before the project commences, provide the owner/architect with a mock-up for approval.
  2. The mock-up shall be of suitable size as required to accurately represent each color and texture to be utilized on the project.
  3. The mock-up shall be prepared with the same products, tools, equipment and techniques required for the actual applications. The finish used shall be from the same batch as that being used for the project.
  4. The approved mock-up shall be available and maintained at the job site.

### 1.07 DELIVERY, STORAGE AND HANDLING

- A. All Dryvit materials shall be delivered to the job site in the original, unopened packages with labels intact.
- B. Upon arrival, materials shall be inspected for physical damage, freezing or overheating. Questionable materials shall not be used.
1. Materials shall be stored at the job site, and at all times, in a cool, dry location, out of direct sunlight, protected from weather and other sources of damage. Minimum storage temperature shall be as follows:
    - a. DPR, PMR™, HDP™, Weatherlastic® and E™ Finishes, Color Prime™, Primus®, Genesis® and NCB™, 40 °F (4 °C).
    - b. For other products, refer to specific product data sheets.
  2. Maximum storage temperature shall not exceed 100 °F (38 °C). **NOTE: Minimize exposure of materials to temperatures over 90 °F (32 °C). Finishes exposed to temperatures over 110 °F (43 °C) for even short periods may exhibit skinning, increased viscosity and should be inspected prior to use.**
- C. Protect all products from inclement weather and direct sunlight.

### 1.08 PROJECT CONDITIONS

- A. Environmental Requirements
1. Application of wet materials shall not take place during inclement weather unless appropriate protection is provided. Protect materials from inclement weather until they are completely dry.
  2. At the time of Dryvit product application, the air and wall surface temperatures shall be from 40 °F (4 °C) minimum to 100 °F (38 °C) maximum for the following products:
    - a. DPR, PMR, HDP, Weatherlastic and E Finishes, Color Prime, Primus, Genesis and NCB.
    - b. For other products, refer to specific product data sheets.
  3. These temperatures shall be maintained with adequate air ventilation and circulation for a minimum of 24 hours (48 hours for Weatherlastic Finishes, Ameristone, and TerraNeo) thereafter, or until the products are completely dry. Refer to published product data sheets for more specific information.

### 1.09 SEQUENCING AND SCHEDULING

- A. Installation of Cement Board MD Finish System shall be coordinated with other construction trades.

### 1.10 WARRANTY

- A. Dryvit Systems, Inc. shall provide a written limited materials warranty against defective material upon written request. Dryvit shall make no other warranties, expressed or implied. Dryvit does not warrant workmanship. Full details are available from Dryvit Systems, Inc.
- B. The applicator shall warrant workmanship separately. Dryvit shall not be responsible for workmanship associated with installation of the Cement Board MD Finish System.

### 1.11 DESIGN RESPONSIBILITY

- A. It is the responsibility of both the specifier and the purchaser to determine if a product is suitable for their intended use. The designer selected by the purchaser shall be responsible for all decisions pertaining to design, detail, structural capability, attachment details, shop drawings and the like. Dryvit has prepared guidelines in the form of specifications, application details, and product data sheets to facilitate the design process only. Dryvit is not liable for any errors or omissions in design, detail, structural capability, attachment details, shop drawings, or the like, whether based upon the information prepared by Dryvit or otherwise, or for any changes which purchasers, specifiers, designers, or their appointed representatives may make to Dryvit's published comments.

**1.12 MAINTENANCE**

- A. All Dryvit products are designed to require minimal maintenance. However, as with all building products, depending on location, some cleaning and minimal maintenance may be required. See Dryvit publication [DS152](#) on Cleaning and Recoating.
- B. Sealants and flashings shall be inspected by the owner or their agent on a regular basis and repairs made as necessary.

**PART II-PRODUCTS****2.01 MANUFACTURER:**

- A. All components of the Cement Board MD Finish System shall be obtained from Dryvit or its authorized distributors.

**2.02 MATERIALS**

- A. Water-Resistive Barrier (not a component of the Dryvit finish system except for Backstop® NT™).
  - 1. Dryvit Backstop NT: A vapor permeable, flexible, polymer-based noncementitious water-resistive and air barrier coating available in Texture, Smooth, and Spray. See [DS180](#) and [DS181](#).
  - 2. Dryvit Backstop NT-VB: A Class 1 vapor retarder, available in trowel and spray versions. When specified, consider having a WVT analysis performed. See [DS830](#) and [DS831](#).
  - 3. Dryvit Grid Tape™: A 4 in (102 mm) wide, open weave fiberglass mesh tape used to reinforce sheathing joints and exposed edges of sheathing.
  - 4. Other code approved water-resistive barrier (when selected by others) is not a component of the Dryvit finish system.
- B. Dryvit MD Spacer™: A polyethylene spacer, which separates the exterior cement board from the sheathing substrate. If other spacers are used, they are not part of the Dryvit finish system.
- C. Exterior Cement Board (by others) and cement board fasteners (by others) are not components of the Dryvit finish system.
- D. Dryvit Base Coat
  - 1. Cementitious: A liquid polymer based material, which is field mixed in a 1:1 ratio by weight with Portland Cement.
    - a. Shall be Genesis®.
  - 2. Ready mixed: A dry blend cementitious, polymer-based product, field mixed with water.
    - a. Shall be Genesis® DM.
  - 3. Sprayable: A dry blend cementitious, polymer-modified product, field mixed with water and specifically formulated for spray applications to provide longer pot life, less false set, extended open time and stronger wet grip.
    - a. Shall be Genesis® DMS.
- E. Machine Coated EPS Shapes and Starter Boards: Shall be supplied by a manufacturer that subscribes to the Dryvit third party certification and quality assurance program.
- F. Reinforcing Mesh(es): Shall be a balanced open weave, glass fiber fabric treated for compatibility with other system materials.
  - 1. Dryvit Detail Mesh®: 4.3 oz/yd<sup>2</sup> (146 g/m<sup>2</sup>), 9 1/2 in (241 mm) wide. Required at all exterior cement board joints and inside and outside corners.
  - 2. Dryvit Standard Mesh: 4.3 oz/yd<sup>2</sup> (146 g/m<sup>2</sup>). Shall be installed over the entire exterior cement board face.
- G. Dryvit Finish: Shall be the type, color and texture as selected by the owner/architect and shall be one or more of the following:
  - 1. Standard DPR (Dirt Pickup Resistance): Water based, acrylic coatings with integral color and texture and formulated with DPR chemistry:
    - a. Quarzputz® DPR: Open-texture pattern.
    - b. Sandblast® DPR: Medium texture.
    - c. Freestyle® DPR: Fine texture.
    - d. Sandpebble® DPR: Pebble texture.
    - e. Sandpebble® DPR Fine: Fine pebble texture.
  - 2. Hydrophobic (HDP™) Finishes: 100% acrylic coating with integral color and texture and formulated with hydrophobic properties:
    - a. Quarzputz® HDP
    - b. Sandblast® HDP
    - c. Sandpebble® HDP
    - d. Sandpebble® Fine HDP

3. **E** Finishes™: Water-based, lightweight acrylic coatings™ with integral color and texture and formulated with DPR chemistry:
  - a. Quarzputz® **E**
  - b. Sandpebble® **E**
  - c. Sandpebble® Fine **E**
4. Specialty Finishes and Veneers:
  - a. Ameristone™: Multi colored quartz aggregate.
  - b. Stone Mist®: Ceramically colored quartz aggregate.
  - c. Custom Brick™: Acrylic polymer finish used in conjunction with a proprietary template system to create the look of stone, brick, slate or tile.
  - d. TerraNeo®: 100% acrylic-based finish with large mica chips and multi-colored quartz aggregates.
  - e. NewBrick®: A lightweight insulated brick veneer for use on exterior walls.
5. Elastomeric DPR (Dirt Pickup Resistance) Finishes: Water-based, elastomeric acrylic finishes with integral color and texture and formulated with DPR chemistry:
  - a. Weatherlastic® Quarzputz
  - b. Weatherlastic® Sandpebble
  - c. Weatherlastic® Sandpebble Fine
  - d. Weatherlastic® Adobe
6. Medallion Series PMR™ (Proven Mildew Resistance) Finishes: Water based, acrylic finishes with integral color and texture:
  - a. Quarzputz® PMR
  - b. Sandblast® PMR
  - c. Freestyle® PMR
  - d. Sandpebble® PMR
  - e. Sandpebble® Fine PMR
7. Coatings, Primers and Sealers:
  - a. Demandit® Smooth
  - b. Demandit® Sanded
  - c. Demandit® Advantage™
  - d. HDP Water-Repellent Coating
  - e. Weatherlastic® Smooth
  - f. Tuscan Glaze™
  - g. Color Prime™
  - h. Prymit®
  - i. SealClear™
- H. Expanded polystyrene (if applicable): Shall be 1 pcf nominal density meeting [DS131](#). EPS must meet the specification of Dryvit Systems, Inc. and be produced by a manufacturer licensed by Dryvit.
- I. Accessories (by others) are not components of the Dryvit finish system.
  1. Type, style and manufacturer shall be indicated on construction documents.
  2. In corrosive environments, accessories manufactured of PVC or zinc are recommended.
  3. Steel accessories shall meet ASTM C 841.
  4. PVC accessories shall meet ASTM D 1784 and C 1063.

## PART III-EXECUTION

### 3.01 EXAMINATION

- A. Prior to installation of the Cement Board MD Finish System, it is the contractor's responsibility to ensure that:
  1. The sheathing substrate is of a type listed in Section 1.05 A.2.a.
  2. The sheathing substrate and the exterior cement board surface are free of dust, loose particles, oil and other conditions that would affect the adhesion or installation of Cement Board MD Finish System materials.
  3. All fasteners are corrosion resistant and installed in a manner as to be flush with the surface of the cement board.
  4. All accessories including corner aids, control and expansion joints, casing beads, etc. are properly fastened and positioned according to contract drawings, manufacturer requirements and local building code requirements.
  5. The water-resistive barrier is of a proper type and, if sheet form, has been installed in a weatherboard fashion in accordance with building code and manufacturer's requirements.
  6. Doors, windows, decks, and other openings and penetrations have been properly flashed in accordance with manufacturer requirements, building code and contract documents.
  7. Metal roof flashing has been installed in accordance with Asphalt Roofing Manufacturers Association (ARMA) Standards.
  8. The cement board surface is flat within 1/4 in (6.4 mm) in 10 ft (3 m).
  9. The contractor shall notify the general contractor and/or owner and/or architect of all discrepancies. Do not proceed until unsatisfactory conditions are resolved.

**3.02 PREPARATION**

- A. The Cement Board MD Finish System materials shall be protected by permanent or temporary means from weather and other damage prior to, during, and following application, until dry.
- B. Protect adjoining work and property.

**3.03 INSTALLATION**

## A. Mixing:

- 1. Backstop NT: Due to shipping and storage, there may be some settling of materials. Prior to using, mix the material to a smooth homogeneous consistency.
- 2. Dryvit base coat materials shall be mixed in accordance with current Dryvit printed Product Sheets.
  - a. Dryvit Genesis shall be mixed in a 1:1 ratio with Portland cement. The mix is allowed to set for 5 minutes and then remixed to break the set. Refer to Genesis product sheet [DS417](#) for complete instructions.
  - b. Dryvit Genesis DM shall be mixed with water to a uniform consistency, allowed to set for 10 minutes and then remixed to break the set. Refer to Genesis DM product sheet [DS452](#) for complete instructions.
  - c. Dryvit Genesis DMS shall be mixed with water to a uniform consistency, allowed to set for 5 minutes and then remixed to break the set. Refer to Genesis DMS product sheet [DS471](#) for complete instructions.
- 3. Dryvit Finishes:
  - a. Dryvit Finishes are factory blended and require no additives. Mix each pail to a uniform consistency adding a small amount of water as needed to adjust workability. Ensure that the same amount of water is added to each pail of the same color.
  - b. Refer to the product data sheet for the specific finish being used for more complete instructions.

## B. Application of Backstop NT:

- 1. Prepare the substrate sheathing so as to be free of foreign materials such as oil, dust, dirt, paint, wax, water repellents, moisture, frost and any other materials that may inhibit adhesion.
- 2. Backstop NT can be applied using a roller, trowel, or spray equipment (with backrolling) over the approved substrates. Refer to Backstop NT Application Instructions, [DS181](#).

## C. Installation of Dryvit MD Spacer:

- 1. Secure the Dryvit MD Spacer to the substrate using corrosion resistant staples through the water-resistive barrier and into the substrate or framing. The spacer is 1/8 in (3.2 mm) thick by 3 in (76 mm) wide and is installed in continuous vertical strips spaced a maximum of 16 in (406 mm) on center installed over each framing member. Additionally, install the spacer flush with the vertical edge of all system terminations and changes in wall direction. If other spacers are used, follow manufacturers' instructions.

## D. Install the exterior cement board in accordance with manufacturer's instructions and project requirements.

- 1. Align sheathing joints with the MD Spacer and install fasteners through the MD Spacer or other spacers as needed.
- 2. Do not align joints with corners of wall penetrations.
- 3. Exterior cement board joints shall be offset from sheathing board substrate joints.

## E. Foam shape application (if applicable)

- 1. Adhere EPS shape to exterior cement board prior to applying the base coat.
- 2. Install in accordance with current Dryvit printed Outsulation® System Application Instructions [DS204](#).

## F. Application of Base Coat:

- 1. Apply Genesis or Genesis DM over all exterior cement board joints and inside and outside corners and embed a 9 1/2 in (241 mm) wide strip of Dryvit Detail Reinforcing Mesh into the wet base coat mixture.
- 2. Allow the base coat mixture to take up until firm to the touch.
- 3. Apply a continuous layer of Genesis, Genesis DM or Genesis DMS over the exterior cement board face and embed a layer of Dryvit Standard Reinforcing Mesh into the wet base coat mixture such that the entire surface of the board is covered. The reinforced base coat shall be applied to a uniform thickness of approximately 1/16 in (1.6 mm) and be sufficient to embed the reinforcing mesh.
- 4. All edges of reinforcing mesh shall be lapped a minimum of 2 1/2 inches (64 mm).

## G. Application of Finishes:

- 1. Allow the Genesis, Genesis DM or Genesis DMS to cure a minimum of 24 hours until completely dry.
- 2. Ensure that the surface of the wall is clean, dry and free of any contaminants that may impair the adhesion of surface finish.
- 3. Dryvit finishes may be either spray or trowel applied.
- 4. Always apply the finish to a natural break to avoid visible cold joints.
- 5. Always work the shady side of the wall or provide shading to avoid application in direct sunlight.
- 6. Dryvit finishes shall be applied in accordance with published Dryvit instructions for the specific finish being used. Refer to the published product data sheet for the specified finish.

H. The installation of Pre-Coated EPS Shapes and Starter Boards shall be in accordance with Dryvit Publication [DS854](#).

**3.04 FIELD QUALITY CONTROL**

- A. The contractor shall be responsible for the proper application of the Cement Board MD Finish System materials.
- B. Dryvit assumes no responsibility for on-site inspections or application of its products.
- C. Independent third party inspection is required to verify installation according to code and contract documents. As a minimum, it is recommended that inspection items include installation of the water-resistive barrier, flashings, and accessories, Cement Board MD Finish System materials, and sealants.

**3.05 CLEANING**

- A. All excess Cement Board MD Finish System materials shall be removed from the job site by the contractor in accordance with contract provisions.
- B. All surrounding areas, where the Cement Board MD Finish System has been applied, shall be left free of debris and foreign substances resulting from the contractor's work.

**3.06 PROTECTION**

- A. The system shall be protected from weather and other damage until permanent protection in the form of flashings, sealants, etc. are installed.

**CAUTIONS AND LIMITATIONS**

- Use is limited to applications on projects not exceeding 5 stories.
- Minor cracking is possible in the finished exterior surface.
- Non-insulated claddings may exhibit shadowing (ghosting) of fasteners and or framing members due to varying exterior surface temperatures. Critical light will tend to exaggerate construction irregularities when coatings are applied directly to sheathing in framed construction.
- Base coat material shall not be used to level wall surface imperfections.
- Consult exterior cement board manufacturer requirements for stud spacing, fastening requirements and other design and installation considerations.

**DISCLAIMER**

Information contained in this specification conforms to standard detail and product recommendations for the installation of the Cement Board MD Finish System products as of the date of publication of this document and is presented in good faith. Dryvit Systems, Inc. assumes no liability, expressed or implied, as to the architecture, engineering or workmanship of any project. To ensure that you are using the latest, most complete information, contact Dryvit Systems, Inc. at:

One Energy Way  
West Warwick, RI 02893  
(401) 822-4100  
[www.dryvit.com](http://www.dryvit.com)

---

Dryvit Systems, Inc.  
One Energy Way  
West Warwick, RI 02893  
(800) 556-7752  
[www.dryvit.com](http://www.dryvit.com)

For more information on [Dryvit Systems](#) or [Continuous Insulation](#),  
visit these links.



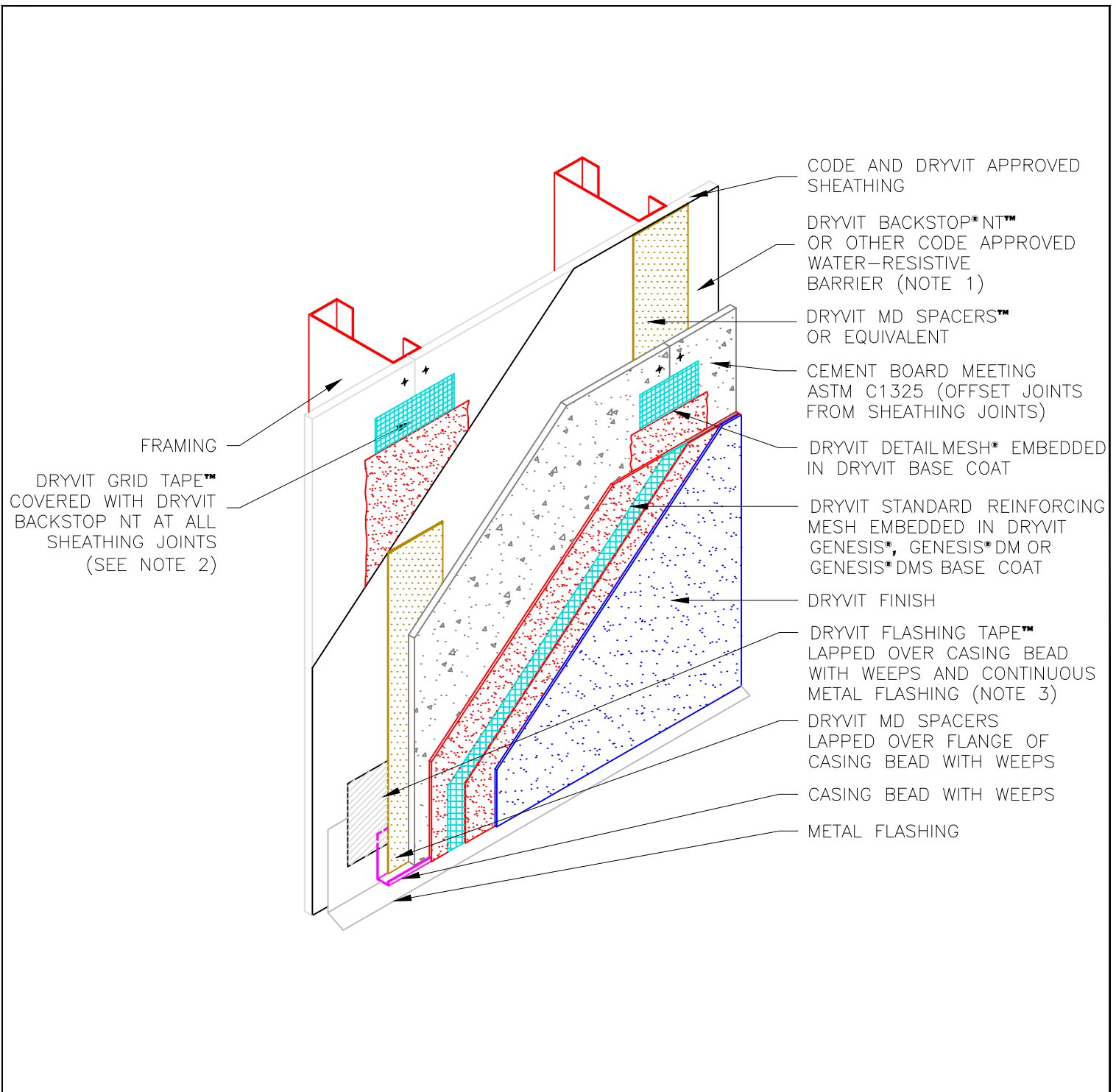

## Cement Board MD Finish System™

## System Layout

**NOTE:**

- 1: SHEET TYPE WATER-RESISTIVE MEMBRANES SHALL BE INSTALLED IN A WEATHER BOARD FASHION
- 2: DRYVIT GRID TAPE NOT REQUIRED WHEN SHEET TYPE WATER-RESISTIVE BARRIERS ARE SPECIFIED
- 3: DRYVIT AQUAFLASH® SYSTEM MAY BE USED IN LIEU OF DRYVIT FLASHING TAPE WHEN DRYVIT BACKSTOP NT IS USED AS THE WATER-RESISTIVE BARRIER

The architecture, engineering, and design of the project using the Dryvit products is the responsibility of the project's design professional. All systems must comply with local building codes and standards. This detail is for general information and guidance only and Dryvit specifically disclaims any liability for the use of this detail and for the architecture, design, engineering or workmanship of any project. The project design professional determines, in its sole discretion, whether this detail or a functionally equivalent detail is best suited for the project. Use of a functionally equivalent detail does not violate Dryvit's warranty. This detail is subject to change without notice. Contact Dryvit to ensure you have the most recent version.

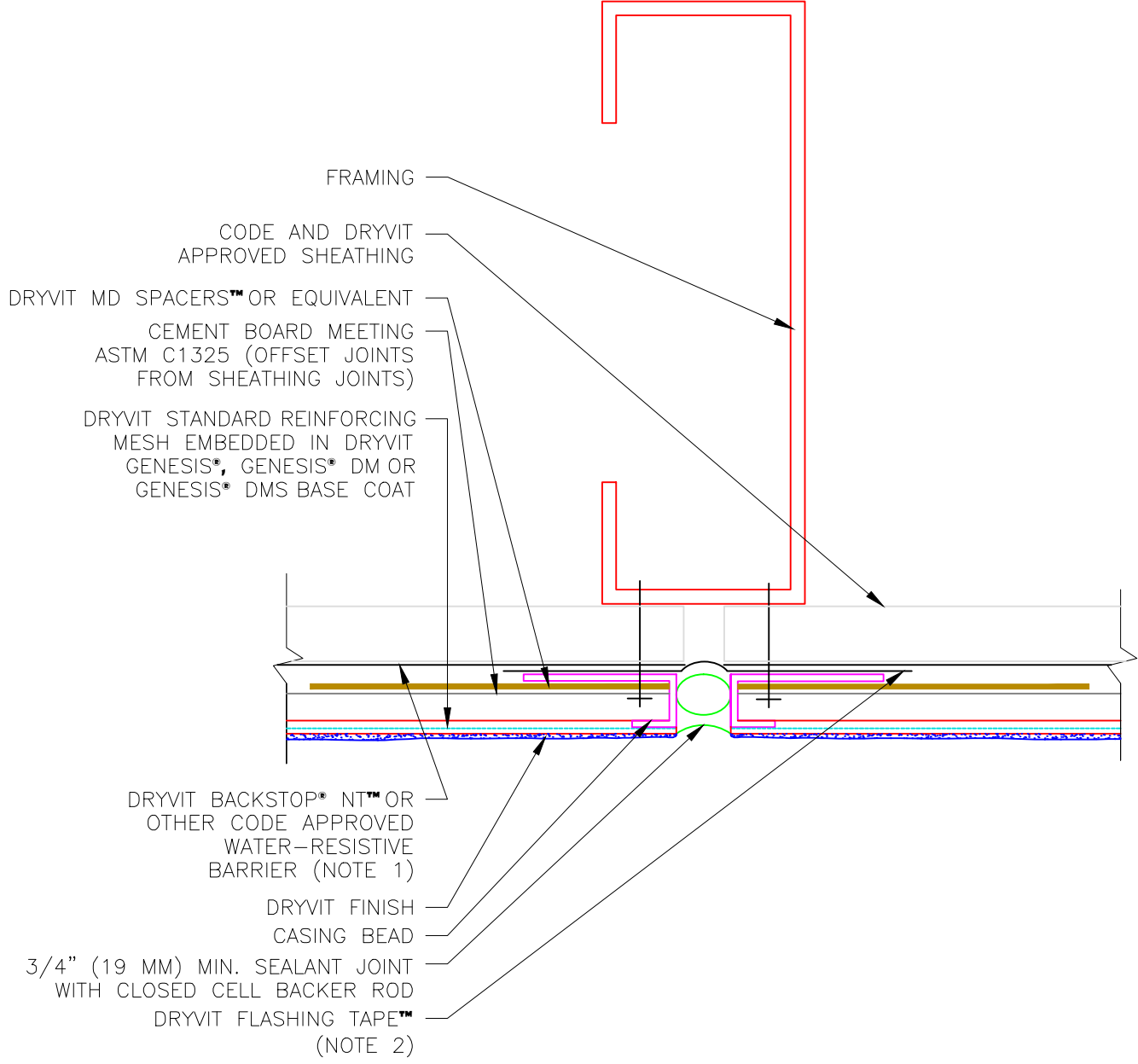

**Cement Board MD Finish System™ Vertical Control/Expansion Joint**

**NOTE:**

- 1: SHEET TYPE WATER-RESISTIVE MEMBRANES SHALL BE INSTALLED IN A WEATHER BOARD FASHION
- 2: DRYVIT AQUAFLASH® SYSTEM MAY BE USED IN LIEU OF DRYVIT FLASHING TAPE WHEN DRYVIT BACKSTOP NT IS USED AS THE WATER-RESISTIVE BARRIER

The architecture, engineering, and design of the project using the Dryvit products is the responsibility of the project's design professional. All systems must comply with local building codes and standards. This detail is for general information and guidance only and Dryvit specifically disclaims any liability for the use of this detail and for the architecture, design, engineering or workmanship of any project. The project design professional determines, in its sole discretion, whether this detail or a functionally equivalent detail is best suited for the project. Use of a functionally equivalent detail does not violate Dryvit's warranty. This detail is subject to change without notice. Contact Dryvit to ensure you have the most recent version.



**SHERWIN  
WILLIAMS.**

# Bond-Plex®

## Waterbased Acrylic Coating

B71W00211 Extra White, B71T00204 Clear Tint Base, B71S00200 Aluminum

### CHARACTERISTICS

**Bond-Plex Waterbased Acrylic Coating** is a single component, waterborne acrylic, adhesion promoting coating formulated for direct application to pre-finished metal siding. Suitable for interior or exterior use.

**Features:**

- Outstanding adhesion
- Eliminates the use of a bonding primer over certain pre-finished siding or other hard, slick, glossy surfaces
- Outstanding application characteristics
- Suitable for use in USDA inspected facilities

**For use over properly prepared pre-finished siding:**

- Fluorocarbons (Kynar®)
- Polyester Polymers
- Silicone Polyesters

**Recommended For:**

- Light Industrial
- Pre-finished Siding
- Manufacturing Facilities, New Construction

**Finish:** 15-25 @ 85° Low Sheen  
Aluminum 70° @ 60° Gloss

**Color:** Many Colors

**Recommended Spreading Rate per coat:**

(Extra White B71W00211 (may vary by color))

Wet mils:	5.0-10.0
Dry mils:	2.4-4.1
Coverage:	160-328 sq. ft. per gallon
Theoretical Coverage:	657 sq. ft. per gallon @ 1 mil dry

Approximate spreading rates are calculated on volume solids and do not include any application loss.

**Note:** Brush or roll application may require multiple coats to achieve maximum film thickness and uniformity of appearance.

**Drying Schedule @ 5.0 mils wet, @ 50% RH:**

Drying and recoat times are temperature, humidity, and film thickness dependent.

	@50°F	@77°F	@120°F
To touch	1.5 hours	45 minutes	20 minutes
Tack free	6 hours	4 hours	2 hours
To recoats	8 hours	4 hours	2 hours

**Tinting with CCE only:**

Base	oz. per gallon	Strength
Extra White	0-4	SherColor
Deep Base	10-12	SherColor

**Do Not Tint Aluminum**

**Extra White B71W00211**

(may vary by color)

**V.O.C. (less exempt solvents):**

less than 50 grams per litre; 0.42 lbs. per gallon

Aluminum 102 grams per litre; 0.85 lbs. per gallon

As per 40 CFR 59.406

**Volume Solids:** 39 ±2%

**Weight Solids:** 55 ±2%

**Weight per Gallon:** 10.90 lbs

**Flash Point:** N/A

**Vehicle Type:** Acrylic

**Shelf Life:** 36 months, unopened

Aluminum 12 months

### COMPLIANCE

As of 12/19/2022, Complies with:

<b>OTC</b>	Yes
<b>OTC Phase II</b>	Yes
<b>S.C.A.Q.M.D.</b>	Yes
<b>CARB</b>	Yes
<b>CARB SCM 2007</b>	Yes
<b>CARB SCM 2020</b>	Yes
<b>Canada</b>	Yes
<b>LEED® v4 &amp; v4.1 Emissions</b>	No
<b>LEED® v4 &amp; v4.1 V.O.C.</b>	Yes
<b>EPD-NSF® Certified</b>	No
<b>MIR-Manufacturer Inventory</b>	No
<b>MPI®</b>	No

### APPLICATION

**Temperature:**  
minimum 50°F / 10°C  
maximum 120°F / 49°C  
air, surface and material  
At least 5°F above dew point

**Relative humidity:** 85% maximum  
The following is a guide. Changes in pressures and tip sizes may be needed for proper spray characteristics. Always purge spray equipment before use with listed reducer. Any reduction must be compatible with the existing environmental and application conditions.

**Reducer:** Water

**Airless Spray:**  
Pressure 2400 p.s.i.  
Hose 1/4-3/8 inch I.D.  
Tip .017-.019 inch  
Filter 60 mesh

**Conventional Spray:**  
Gun Binks 95  
Fluid Nozzle 66  
Air Nozzle 63 PB  
Atomization Pressure 60 p.s.i.  
Fluid Pressure 25 p.s.i.

**Reduction:** As needed up to 10% by volume

**Brush:** Nylon-polyester

**Roller Cover:** 1/2 inch woven-small surfaces only  
If specific application equipment is listed above, equivalent equipment may be substituted. Consult spray manufacturer for more information on equipment variations.

Apply paint at the recommended film thickness and spreading rate as indicated. Application of coating above maximum or below minimum recommended spreading rate may adversely affect coating performance. Spreading rates are calculated on volume solids and do not include an application loss factor due to surface profile, roughness, or porosity of the surface, skill, and technique of the applicator, method of application, various surface irregularities, material loss during mixing, spillage, over thinning, climatic conditions, and excessive film build.

Mix paint thoroughly to a uniform consistency with slow speed power agitation prior to use.

Stripe coat crevices, welds, and sharp angles to prevent early failure in these areas. When using spray application, use 50% overlap with each pass of the gun to avoid holidays, bare areas, and pinholes. If necessary, cross spray at a right angle.

During the early stages of drying, the coating is sensitive to rain, dew, high humidity, and moisture condensation. Plan painting schedules to avoid these influences during the first 16-24 hours of curing.

### SPECIFICATIONS

**Pre-Finished Siding: Fluorocarbon, Silicone Polyester, Polyester Polymers:**  
1-2 coats Bond-Plex Waterbased Acrylic

**Previously Painted, Hard, Slick, Glossy Surfaces:**  
1-2 coats Bond-Plex Waterbased Acrylic

**Pre-Finished Siding: Fluorocarbon, Silicone Polyester, Polyester Polymers:**  
1 coat Bond-Plex Waterbased Acrylic  
1-2 coats of Acceptable topcoat

**Previously Painted, Hard, Slick, Glossy Surfaces:**  
1 coat Bond-Plex Waterbased Acrylic  
1-2 coats of Acceptable topcoat

**Acceptable Topcoats:**  
Pro Industrial Acrylic  
Pro Industrial DTM Primer/Finish  
Pro Industrial Multi-Surface Acrylic  
Pro Industrial Waterbased Acrolon 100  
Pro Industrial Waterbased Alkyd Urethane Enamel  
Pro Industrial Pre-Catalyzed Waterbased Urethane

Always check compatibility of the previously painted surface with the new coating by applying a test patch of 2-3 square feet. Allow to dry thoroughly for 1 week before checking adhesion.

The systems listed above are representative of the product's use. Other systems may be appropriate.

# Bond-Plex<sup>®</sup>

## Waterbased Acrylic Coating

### SURFACE PREPARATION

**WARNING!** If you scrape, sand or remove old paint, you may release lead dust. LEAD IS TOXIC. EXPOSURE TO LEAD DUST CAN CAUSE SERIOUS ILLNESS, SUCH AS BRAIN DAMAGE, ESPECIALLY IN CHILDREN. PREGNANT WOMEN SHOULD ALSO AVOID EXPOSURE. Wear a NIOSH-approved respirator to control lead exposure. Clean up carefully with a HEPA vacuum and a wet mop. Before you start, find out how to protect yourself and your family by contacting the National Lead Information Hotline at 1-800-424-LEAD or log on to [www.epa.gov/lead](http://www.epa.gov/lead).

When cleaning the surface per SSPC-SP1, use only an emulsifying industrial detergent, followed by a water rinse.

**Do not use hydrocarbon solvents for cleaning.**

Remove all surface contamination by washing with an appropriate cleaner, rinse thoroughly and allow to dry. Existing peeled or checked paint should be scraped and sanded to a sound surface. Glossy surfaces should be sanded dull. Stains from water, smoke, ink, pencil, grease, etc. should be sealed with the appropriate primer-sealer. Recognize that any surface preparation short of total removal of the old coating may compromise the service length of the system.

#### **Pre-Finished Siding Fluorocarbon, Silicone Polyester, Polyester Polymers:**

Remove oil, grease, dirt, oxides, and other contaminants from the surface by cleaning per SSPC-SP1 or water blasting per NACE Standard RP-01-72 (caution: excessive blasting pressure may cause warping, use caution). Always check compatibility of the previously painted surface with the new coating by applying a test patch of 2-3 square feet. Allow to dry thoroughly for 1 week before checking adhesion.

#### **Previously Painted Surface:**

If in sound condition, clean the surface of all foreign material. Smooth, hard or glossy coatings and surfaces should be dulled by abrading the surface. Always check compatibility of the previously painted surface with the new coating by applying a test patch of 2-3 square feet. Allow to dry thoroughly for 1 week before checking adhesion. If adhesion is poor, additional abrasion of the surface and/or removal of the previous coating may be necessary. Retest surface for adhesion. If paint is peeling or badly weathered, clean surface to sound substrate and treat as a new surface as above. Recognize that any surface preparation short of total removal of the old coating may compromise the service length of the system.

### SURFACE PREPARATION

#### **Mildew:**

Prior to attempting to remove mildew, it is always recommended to test any cleaner on a small, inconspicuous area prior to use. Bleach and bleaching type cleaners may damage or discolor existing paint films. Bleach alternative cleaning solutions may be advised.

Mildew may be removed before painting by washing with a solution of 1 part liquid bleach and 3 parts clean water. Apply the solution and scrub the mildewed area. Allow the solution to remain on the surface for 10 minutes. Rinse thoroughly with clean water and allow the surface to dry before painting. Wear protective eyewear, waterproof gloves, and protective clothing. Quickly wash off any of the mixture that comes in contact with your skin. Do not add detergents or ammonia to the bleach-water solution.

### PERFORMANCE

**B71W00211 Bond-Plex @ 4.0 mils D.F.T.**  
(unless otherwise noted)

#### **Abrasion Resistance:**

Method: ASTM D4060, CS17 Wheel, 1000 cycles, 1kg load  
Result: 90.03 mg loss

#### **Adhesion:**

Method: ASTM D4541  
Result: 1477 p.s.i.

#### **Corrosion Weathering\*:**

Method: ASTM D5894, 8 cycles  
Result: Rating 8.5 for rusting  
Rating 10 for blistering

#### **Direct Impact Resistance:**

Method: ASTM D2794  
Result: greater than 176 inch pound

#### **Dry Heat Resistance:**

Method: ASTM D2485  
Result: 200°F/93°C

#### **Flexibility:**

Method: ASTM D522, 180° bend, 1/4 inch mandrel  
Result: Pass

#### **Humidity Resistance:**

Method: ASTM D4585, 1443 hours  
Result: Rating 10 for rusting  
Rating 10 for blistering

#### **Pencil Hardness:**

Method: ASTM D3363  
Result: 1.5B

#### **Salt Fog Resistance\*:**

Method: ASTM B117, 274 hours  
Result: Rating 8 for rusting  
Rating 8D for blistering

\*1 coat Pro Industrial Pro-Cryl Primer  
1 coat Bond-Plex

### SAFETY PRECAUTIONS

Before using, carefully read **CAUTIONS** on label.

Refer to the Safety Data Sheets (SDS) before use.

#### **FOR PROFESSIONAL USE ONLY.**

Published technical data and instructions are subject to change without notice. Contact your Sherwin-Williams representative for additional technical data and instructions.

### CLEANUP INFORMATION

Clean spills, spatters, hands and tools immediately after use with soap and warm clean water. After cleaning, flush spray equipment with compliant cleanup solvent to prevent rusting of the equipment. Follow manufacturer's safety recommendations when using solvents.

HOTW	12/19/2022	B71W00211	27	45
HOTW	12/19/2022	B71T00204	22	48
HOTW	12/19/2022	B71S00200	21	102

**Agenda Item:** Application for new Construction, ARB #25-006

**Meeting Date:** January 7, 2026

**Category:** Public Hearings

**Prepared by:** Angelina Jones, Lead Planner / Design and Development

**Description:**

This application proposes to demolish the existing concrete masonry unit (CMU) dugouts at the Bready Park youth baseball stadium and to construct replacement dugouts in the same location. Two or three courses of the CMU walls would be retained and the new dugouts would be built with squared metal posts, chain-link fencing, and a new shed roof clad in metal ribbed panels. The existing tiered wooden benches would remain. The application also proposes a seat wall adjacent to the park's tennis courts. The wall will be 12 inches wide and will range between 12 and 24 inches in height. It will be constructed of split-faced CMU and capped. For additional information, please see the attached staff report.

**Background/Timing Impact:**

The property at 814 Ferndale Avenue features an approximately 11.73-acre public park improved with several active recreation fields and courts, a playground, a surface parking lot, a structured pavilion, an accessory structure with bathrooms, and a youth baseball stadium with a two-story press box and concrete block dugouts. The property also features several mature canopy trees and is immediately adjacent to the Herndon Centennial Golf Course, the Washington and Old Dominion (W&OD) Trail, the Herndon Community Center, and St. Josephs Church and School. For additional information, please see the attached staff report.

**Fiscal Impact:**

N/A

**Legal Impact:**

N/A

**Staff Recommendation/Next Steps:**

Staff is withholding a recommendation at this time pending submission and clarification of the materials and information noted in the attached staff report.

**Attachments:**

1. Staff Report
2. Materials

## STAFF REPORT

**Agenda Item:** ARB #25-006; New Construction; Fairfax County Tax Map 0104 02 0013, 814 Ferndale Avenue

**Meeting Date:** January 7, 2026

**Staff Contact:** Angelina R. Jones, Lead Planner – Development & Design

**Summary Information:**

Proposed Modification	New Construction – Demolition and replacement of two existing dugouts, installation of a seat wall, and other minor site improvements		
Address	814 Ferndale Ave, Herndon, VA 20170		
Fairfax County Tax Map Number	0104 02 0013		
Owners	The Town of Herndon		
Applicant	Zeljko Spasojevic, The Town of Herndon		
Business/Organization	Bready Park/Town of Herndon		
Property Use	Public Land		
Zoning District	R-10, Residential Single-Family - 10 District		
Adjacent Zoning	<b>North:</b> R-10, Residential Single-Family - 10 District <b>East:</b> R-10, Residential Single-Family - 10 District <b>South:</b> R-10, Residential Single-Family - 10 District <b>West:</b> R-10, Residential Single-Family - 10 District		
Building Type(s)	N/A	<b>Date of Construction:</b>	N/A
Architectural Style(s)	N/A		
Exterior Material(s)	N/A		
Neighborhood Design Profile	Mix of public land and single-family residential		
Comprehensive Plan Land Use Designation	Community Facilities		

**Location Map:**

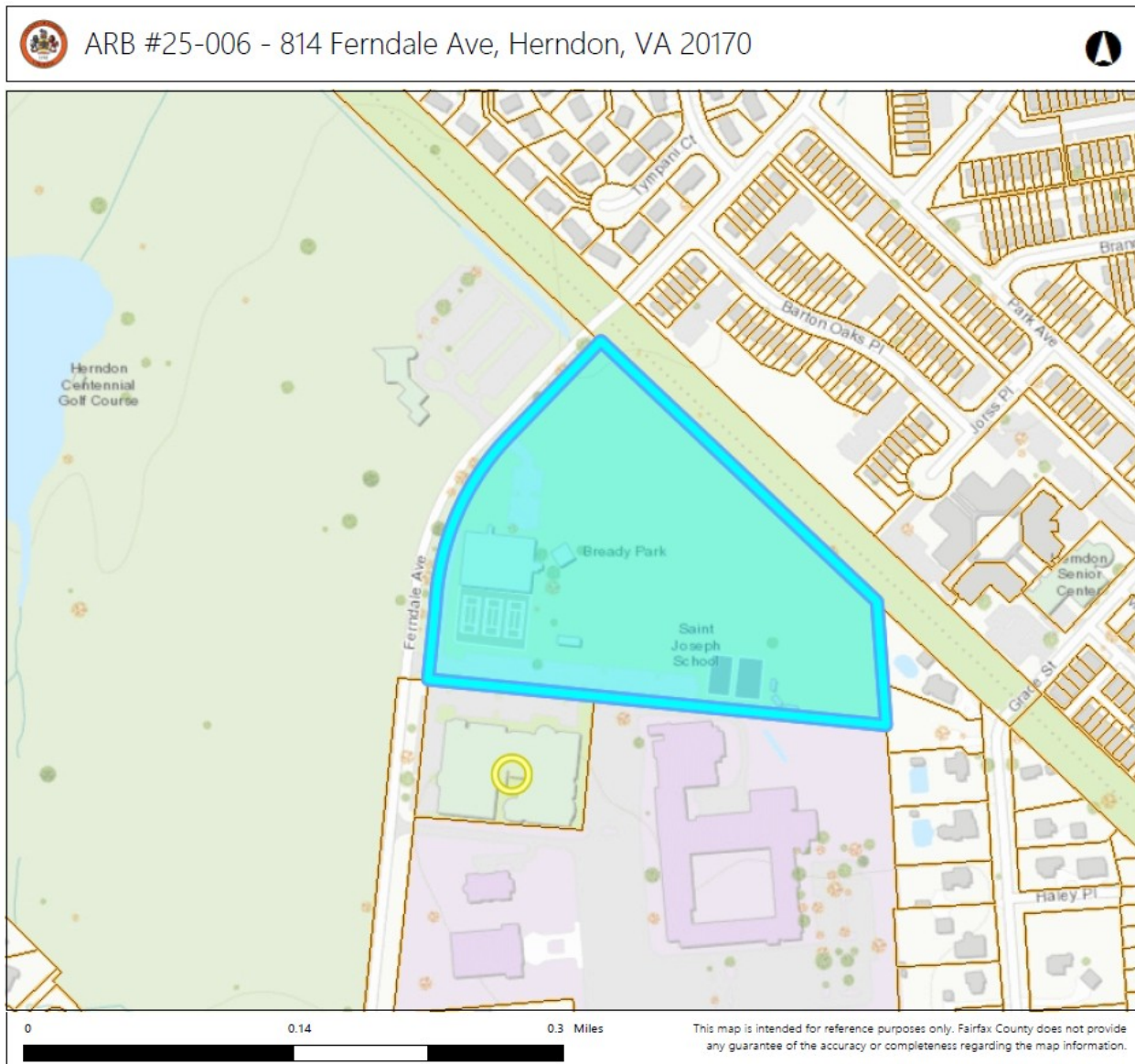

**Background Information:**

Property Description

The property at 814 Ferndale Avenue features an approximately 11.73-acre public park improved with several active recreation fields and courts, a playground, a surface parking lot, a structured pavilion, an accessory structure with bathrooms, and youth baseball stadium with a two-story press box and concrete block dugouts. The property also features several mature canopy trees and is immediately adjacent to the Herndon

Centennial Golf Course, the Washington and Old Dominion (W&OD) Trail, the Herndon Community Center, and St. Josephs Church and School.

**Case Details & Proposal:**

This application proposes to demolish the existing concrete masonry unit (CMU) dugouts at the Bready Park youth baseball stadium (*Figures 1-3*) and to construct replacement dugouts in the same location. Two or three courses of the CMU walls would be retained and the new dugouts would be built with squared metal posts, chain-link fencing, and a new shed roof clad in metal ribbed panels. The existing tiered wooden benches would remain. The application also proposes a seat wall adjacent to the park’s tennis courts. The wall will be 12 inches wide and will range between 12 and 24 inches in height. It will be constructed of split-faced CMU and capped.



*Figure 1: Dugout at Bready Park with press box. December 2025*



*Figure 2: Dugouts at Bready Park with press box in center. December 2025*



Figure 3: Dugout at Bready Park with view of tiered benches. December 2025

### Staff Analysis:

1. Before a full evaluation of this case can be completed, the following information should be clarified and provided with additional specifications and drawings:
  - Material and design of the cap for the seating wall and the knee wall surrounding the dugouts.
  - Powder coating details for the posts and chain link fencing.
  - Color of the split-face block.
  - Clarity on how the new structure will spatially and/or physically interact with remaining CMU wall and existing two-tiered seating.

Staff will provide the code section 58-96 Design Criteria compliance analysis table to the board upon clarification of the items listed above.

2. While chain-link fencing is not often permitted and would typically be considered a material of poor design quality, it is often acceptable for recreational purposes and is used elsewhere in Bready Park as fencing. The only instances in town where it's used as a wall material for an accessory structures is dugouts. This is the case for

the softball field at Bready Park and the youth baseball field at Haley Smith Park. Conversion of masonry dugouts to chain-link dugouts impact the stadium setting at Bready Park and removes the added amenity such a setting has for users.

3. The design of the dugouts overall, including the portions of existing CMU to remain and how it interacts with the existing chain-link elements, the electrical equipment affixed to one of the dugouts, and the existing two-tiered player bench, should be clarified. This may be handled administratively by staff but may be useful for the board review.
4. The removal of the Bready Park mural on the dugout is an unfortunate byproduct of the dugout changes. Other opportunities for artwork and placemaking in Bready Park should be explored to offset the loss of this element.
5. Assuming the wooden dugout benches are to remain, they should be sealed using an oil-based alkyd primer finished with an acrylic latex paint since they will no longer be enclosed and be exposed to weather.

**ARB Alternatives:**

The following alternatives are available to the ARB for its decision on #25-006.

1. Approval as proposed
2. Approval with conditions
3. Denial on specific stated grounds
4. Continuance of the application to a future public hearing

**Staff Recommendation:**

Staff is withholding a recommendation at this time pending submission and clarification of the materials and information noted above.

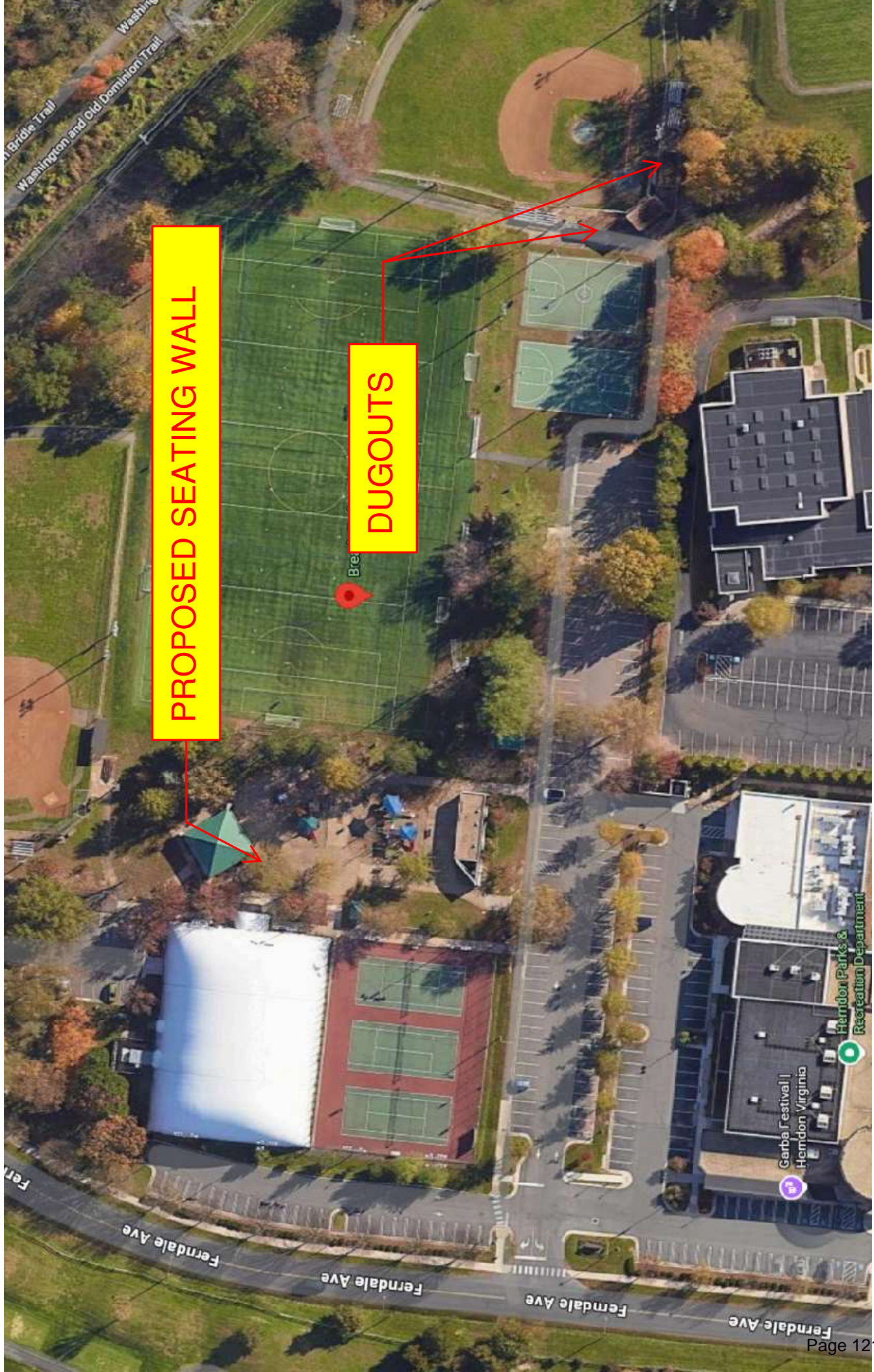

PROPOSED SEATING WALL

DUGOUTS



Garbo Festival |  
Herndon Virginia

Herndon Parks & Recreation Department



## Seat Wall

### Demolition

- Removal of two trees (locations are inside of seat wall area and next to existing transformers). Trees to be removed entirely and stumps to be grinded.
- Demolition of existing asphalt walkway approximately 7'x22'.

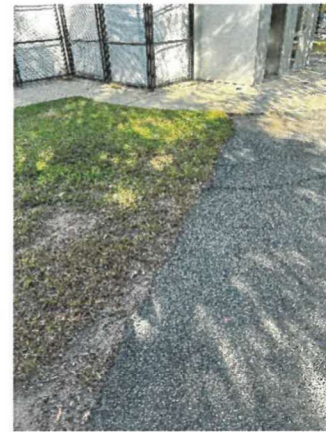
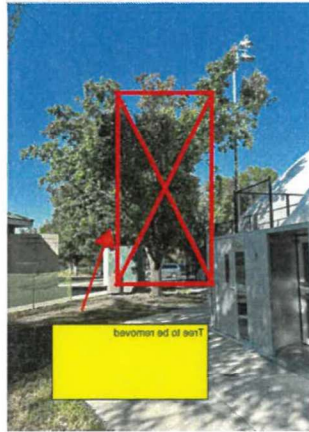
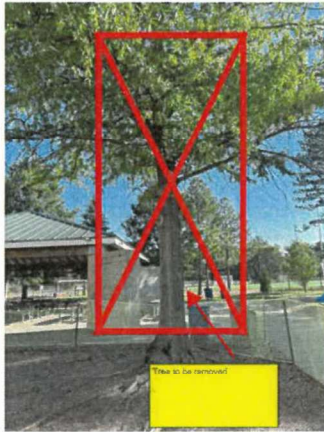

### Excavation

- Trench line to be created from pooling area to existing storm line approximately 1'x21'x3'.
- Dirt around the perimeter of the sidewalk to be excavated for new continuous seat wall footer approximately 2'width 70'length and 30" deep.

### Drain Line

- Furnish and install a new 3' drain line with drain approximately 21' in length and drilled into existing stormwater drain.



## Concrete

- 57 stone aggregate to be poured in excavated areas as subgrade for concrete walkway, footing, and trench line.
- Pouring of new 3,500 PSI concrete approximately 7'x 22' at 4" thickness.
- Pouring of new 3,500 PSI concrete footer 2'x70'x30". #4 rebar rod anchors to be placed approximately every 24" for CMU adherence.

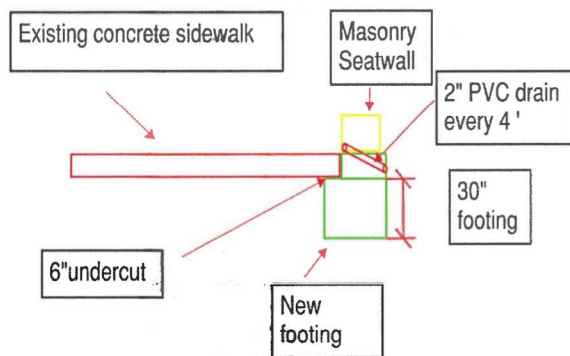

## Masonry

- Furnish and installation of new Split face CMU with cap along perimeter of the existing concrete sidewalk approximately 1' width at 15" height and 70' in length (Coloring to be picked by owner).

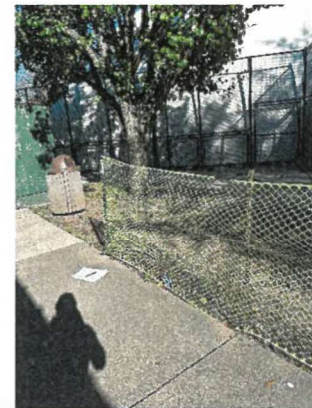
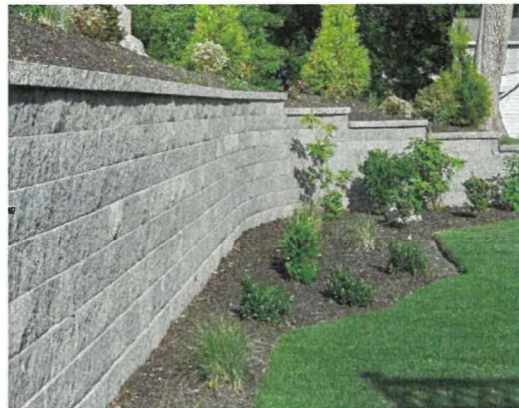

## Backfill

- All areas to be backfilled and sloped to grade of existing and proposed manholes.

## Landscaping

- Work area to be seeded and strawed.

## Masonry

### Standard CMU Coloring

-CMU block can vary in price due to supply, size, and coloring. The following are all standard colors.

-Split Face CMU in 4", 8", 12" stretchers, 8" & 12" open-bottom bond beams, 6" sill, and an 8" universal corner



## Dugouts

### Demolition

- Removal of all roofing pertaining to dugouts.
- Removal of all CMU above proposed cutline shown below.

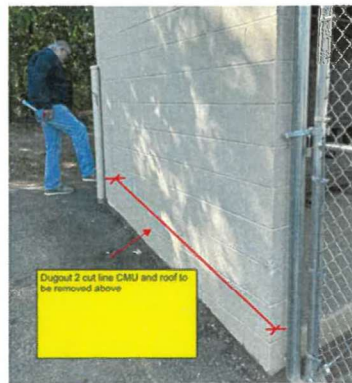

## Dugouts

- Provide and install 2 premanufactured Premium Beacon Athletics Dugouts.



STEEL FRAME COLORS		
almond	black	red
green	burgundy	blue
navy blue	brown	forest green



## Roofing

- Provide and install Roof Panels are 26-gauge galvanized metal roofing for 2 dugouts.

## Fencing

- Furnish and install black sports complex fencing surrounding the new proposed dugouts.

# DUGOUTS USA

National Suppliers of  
Prefabricated, Pre Engineered  
Dugout Structures



Dugouts USA

6565 W Norvell Bryant Hwy, Suite B

Crystal River, FL 34429

Ph. 352-527-7500

[www.dugoutsusa.com](http://www.dugoutsusa.com)

# Typical Drawings

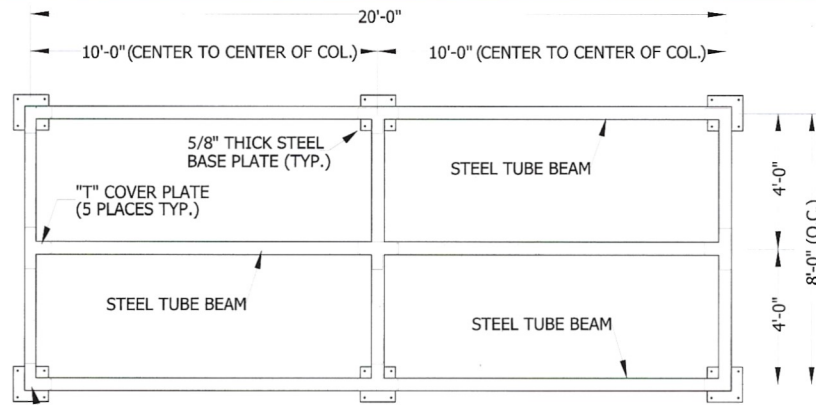

"L" COVER PLATE  
(4 PLACES TYP.)

**PLAN VIEW**

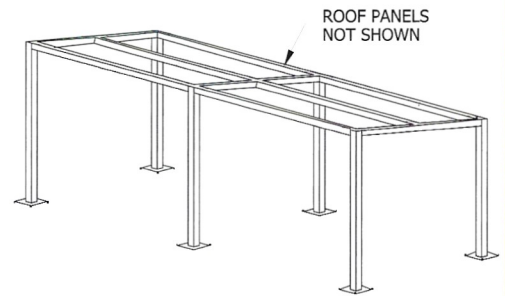

**ISOMETRIC VIEW**

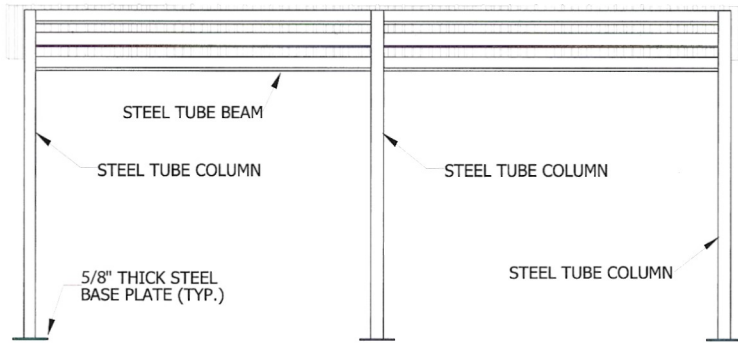

**FRONT ELEVATION**

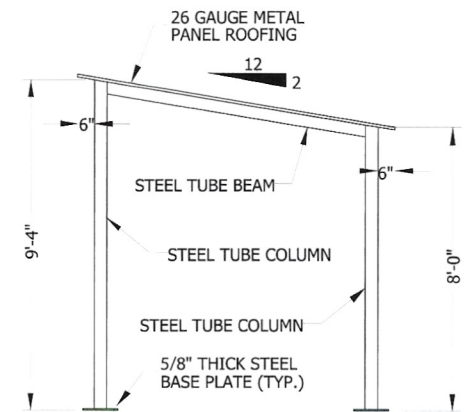

**SIDE ELEVATION**

**Custom Sizes  
Available**

*Examples:*

ST629

ST730

ST824

ST932

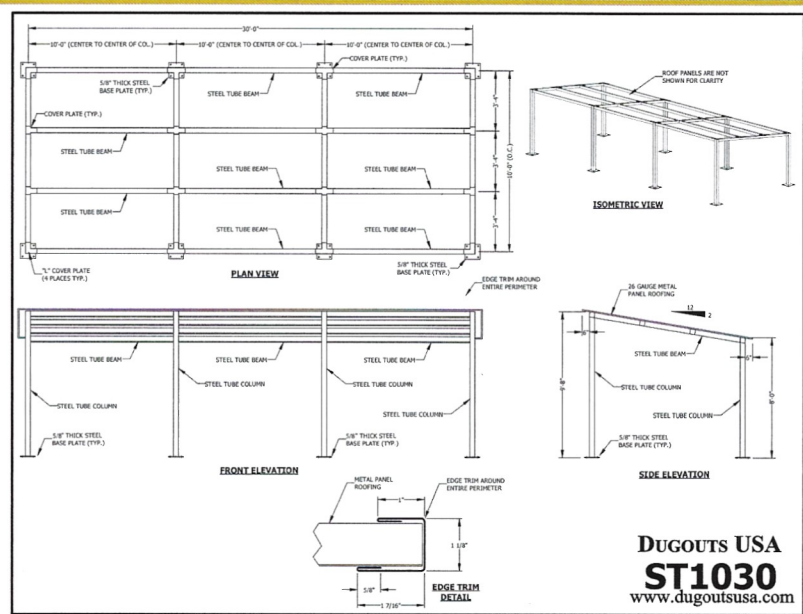

10' Deep Dugout Example

**DUGOUTS USA**  
**ST1030**  
www.dugoutsusa.com

Available Dugout Depths: 5' to 10'  
Available Dugout Lengths: Unlimited  
Available Roof Pitch: 1-12, 2-12, 3-12

[www.dugoutsusa.com](http://www.dugoutsusa.com)

# Dugout Features

- All Steel Construction
- Concealed Frame Fasteners
- Fast Erection with Limited Personnel
- 40 Year Warranty on Metal Roof Color Finish

## Powder Coated Steel Frame Colors\*

Almond RAL 1015	Black RAL 51	Red RAL 3000
Green RAL 6029	Burgundy RAL 3004	Blue RAL 5010
Navy Blue RAL 5013	Brown RAL 8017	Forest Green RAL 6005

## 26 Gauge Metal Roof Colors\*

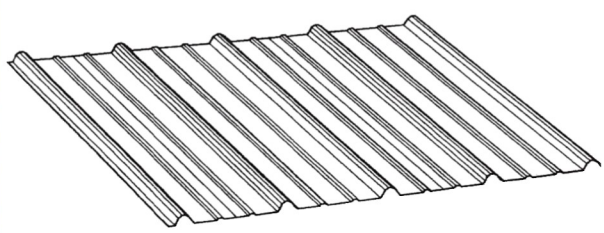

**Profile Detail**

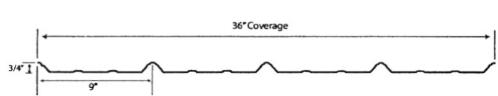

**Sidelap Detail**

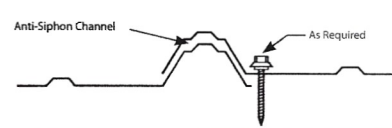

Light Stone	Mocha Tan	Old Town Gray
Pure White	Cocoa Brown	Forest Green
Hawaiian Blue	Barn Red	Galvalume

[www.dugoutsusa.com](http://www.dugoutsusa.com)

\*Actual colors may vary

# Specifications

## STEEL DUGOUT FRAME

- Support Columns shall be fabricated of A500 square structural steel tubing with an electrically welded 5/8" thick A36 steel base plate.
- Beams shall be fabricated of A500 square structural steel tubing.
- Steel frame members shall be blasted to near white metal, cleaned with an 8-Stage pretreatment system, and zinc rich primer coated prior to the finished powder coat process. Powder coat finish shall be TGIC electrostatically applied polyester powder.
- Roofing shall be precut 26 gauge small rib metal panels.
- Fasteners shall be 1" diameter grade 5 bolts with flat washers and locknuts. Bolts meet ASME B18.2.1 with a minimum tensile strength of 120,000 psi. All fasteners shall be concealed inside the tubing.
- Anchors shall be 1/2" diameter x 8 1/2" zinc plated concrete wedge anchors.

## METAL ROOF PANELS

- Panel Profile: 3/4" height rib 36" coverage width
- Panel Style: Sidelap seam or exposed fastener
- Gauge: 26 Gauge
- Substrate: Grade 80 Galvanized steel sheet (G60), conforming to ASTM A446 for painted panels
- Texture: Smooth
- Finish: Ceram-A-Star 1050 high performance silicon-modified polyester
- Color: Selected from manufacturers standard line.

## WARRANTY

Dugouts shall be guaranteed against defects in workmanship or materials for a period of one year from date of invoice by the manufacturer.

DISTRIBUTED BY:

# MASTER DRAWINGS FOR: NEW DUGOUTS (NORTHERN CLIMATE)

### DESIGN PARAMETERS:

APPLICABLE CODES:  
 BUILDING CODES: - CURRENT ADOPTED EDITION - (FBC/IBC)  
 METHOD OF DESIGN:  
 DESIGN PURSUANT TO - CURRENT ADOPTED EDITION - (FBC/IBC)  
 BUILDING OCCUPANCY CLASSIFICATION: GROUP U - UTILITY - ACCESSORY BUILDING  
 RISK FACTOR CURRENT ADOPTED EDITION - (FBC/IBC) - TABLE 1604.5): CATEGORY 1  
 ROOF LIVE LOAD: 20 PSF  
 STRUCTURE DESIGNED IN ACCORDANCE WITH ASCE 7-16 CHAPTERS 26-30  
 BASIC WIND SPEED CURRENT ADOPTED EDITION - (FBC/IBC) - FIGURE 1609.3) SHALL BE BASED ON UP TO 170 MPH WIND SPEED DESIGN - CALCULATIONS PROVIDED BY GPI ENGINEERING  
 SNOW LOADS: (FBC) 2020 7th EDITION - FIGURE 1607 AND ASCE 7 CHAPTER 7 SHALL BE BASED ON UP TO 55 PSF GROUND SNOW LOAD FOR THIS EXAMPLE AND MUST BE VERIFIED FOR EACH PROPOSED LOCATION PRIOR TO FABRICATION - CALCULATIONS PROVIDED BY GREENMAN - PEDERSON, INC. (GPI ENGINEERING) - ADDRESS: 3423 OLNEY - LAYTONSVILLE RD. SUITE #6 OLNEY, MARYLAND 20832  
 LIVE LOAD: CURRENT ADOPTED EDITION - (FBC/IBC) - SECTION 1607 SHALL BE BASED ON 20 PSF BUILDING CONSTRUCTION TYPE CURRENT ADOPTED EDITION - (FBC/IBC) - CHAPTER 6) TYPE IIB (UNPROTECTED UNSPRINKLED)  
 EXPOSURE CATEGORY CURRENT ADOPTED EDITION - (FBC/IBC) - 1609.4.3): PER SITE  
 INTERNAL PRESSURE COEFFICIENTS: OPEN  
 HEIGHT = PER SELECTED MODEL FOUNDATION HAS BEEN DESIGNED FOR AN ALLOWABLE SOIL BEARING PRESSURE OF A MIN. OF 2,000 PSF POUNDS PER SQUARE FOOT IN ACCORDANCE WITH PRESUMPTIVE LOAD BEARINGS VALUES.

### STRUCTURAL FORCES:

ROOF DESIGN	LIVE LOAD	20 PSF
	DEAD LOAD	SELF WEIGHT
	SNOW LOAD	55 PSF EST.
TOTAL LOAD		75 PSF
ROOF DEFLECTION	L/240 LIVE LOAD	
	L/180 TOTAL LOAD	

### ROOF DESIGN WIND PRESSURE (PSF): ASCE 7-16 CHAPTERS 26-30

AREA	ZONE 3		ZONE 2		ZONE 1	
	≤9	17.5	-71.6	17.5	-48.4	17.5
9-36	13.9	-60.8	13.9	-39.4	13.9	-26.0
>36	12.4	-56.2	12.4	-35.6	12.4	-25.2

### ROOF FASTENERS

ZONE 1	#12 X 1" - 4" O.C. HWH SD W/ SEALING WASHERS - SEE NOTE 3
ZONE 2	#12 X 1" - 4" O.C. HWH SD W/ SEALING WASHERS - SEE NOTE 3
ZONE 3	#12 X 1" - 4" O.C. HWH SD W/ SEALING WASHERS - SEE NOTE 3
TRIM FASTENED W/ 1/4" - #14 X 7/8" HWH SD STITCH SCREW W/ SEALING WASHER @ 18" O.C.	

MINIMUM DESIGN LOADS

Components and Cladding	0.25 ≤ h/L ≤ 1.0
Figure 30.8-1	Net Pressure Coefficient, C <sub>N</sub>
Open Buildings	Monoslope Free Roofs θ ≤ 45°

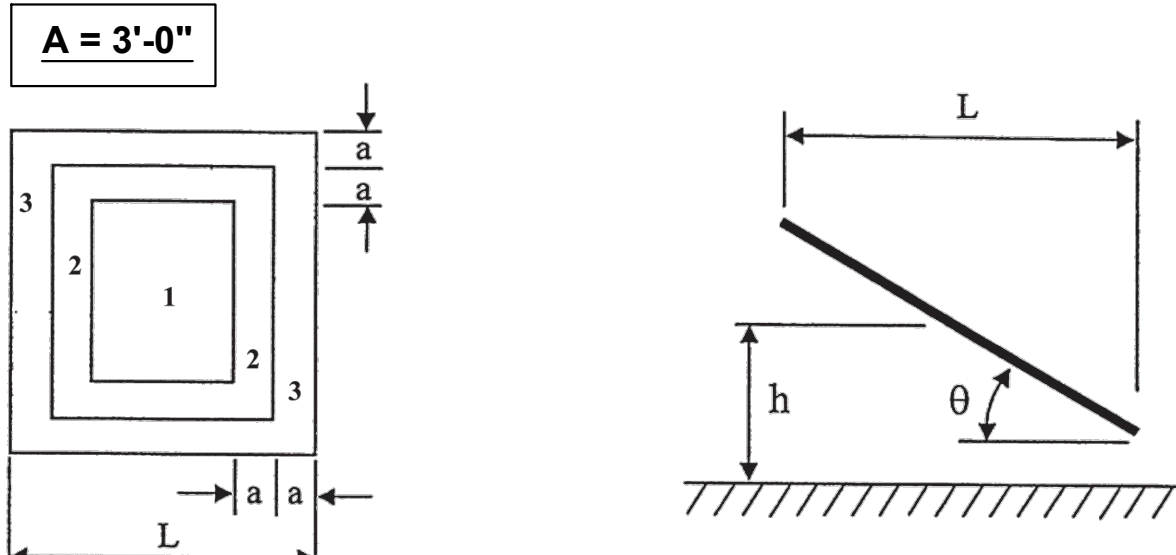

Roof Angle θ	Effective Wind Area	C <sub>N</sub>											
		Clear Wind Flow						Obstructed Wind Flow					
		Zone 3		Zone 2		Zone 1		Zone 3		Zone 2		Zone 1	
0°	≤ a²	2.4	-3.3	1.8	-1.7	1.2	-1.1	1	-3.6	0.8	-1.8	0.5	-1.2
	> a², ≤ 4.0a²	1.8	-1.7	1.8	-1.7	1.2	-1.1	0.8	-1.8	0.8	-1.8	0.5	-1.2
	> 4.0a²	1.2	-1.1	1.2	-1.1	1.2	-1.1	0.5	-1.2	0.5	-1.2	0.5	-1.2
7.5°	≤ a²	3.2	-4.2	2.4	-2.1	1.6	-1.4	1.6	-5.1	1.2	-2.6	0.8	-1.7
	> a², ≤ 4.0a²	2.4	-2.1	2.4	-2.1	1.6	-1.4	1.2	-2.6	1.2	-2.6	0.8	-1.7
	> 4.0a²	1.6	-1.4	1.6	-1.4	1.6	-1.4	0.8	-1.7	0.8	-1.7	0.8	-1.7
15°	≤ a²	3.6	-3.8	2.7	-2.9	1.8	-1.9	2.4	-4.2	1.8	-3.2	1.2	-2.1
	> a², ≤ 4.0a²	2.7	-2.9	2.7	-2.9	1.8	-1.9	1.8	-3.2	1.8	-3.2	1.2	-2.1
	> 4.0a²	1.8	-1.9	1.8	-1.9	1.8	-1.9	1.2	-2.1	1.2	-2.1	1.2	-2.1
30°	≤ a²	5.2	-5	3.9	-3.8	2.6	-2.5	3.2	-4.6	2.4	-3.5	1.6	-2.3
	> a², ≤ 4.0a²	3.9	-3.8	3.9	-3.8	2.6	-2.5	2.4	-3.5	2.4	-3.5	1.6	-2.3
	> 4.0a²	2.6	-2.5	2.6	-2.5	2.6	-2.5	1.6	-2.3	1.6	-2.3	1.6	-2.3
45°	≤ a²	5.2	-4.6	3.9	-3.5	2.6	-2.3	4.2	-3.8	3.2	-2.9	2.1	-1.9
	> a², ≤ 4.0a²	3.9	-3.5	3.9	-3.5	2.6	-2.3	3.2	-2.9	3.2	-2.9	2.1	-1.9
	> 4.0a²	2.6	-2.3	2.6	-2.3	2.6	-2.3	2.1	-1.9	2.1	-1.9	2.1	-1.9

- Notes:
- C<sub>N</sub> denotes net pressures (contributions from top and bottom surfaces).
  - Clear wind flow denotes relatively unobstructed wind flow with blockage less than or equal to 50%. Obstructed wind flow denotes objects below roof inhibiting wind flow (>50% blockage).
  - For values of θ other than those shown, linear interpolation is permitted.
  - Plus and minus signs signify pressures acting towards and away from the top roof surface, respectively.
  - Components and cladding elements shall be designed for positive and negative pressure coefficients shown.
  - Notation:
    - a : 10% of least horizontal dimension or 0.4h, whichever is smaller but not less than 4% of least horizontal dimension or 3 ft. (0.9 m)
    - h : mean roof height, ft. (m)
    - L : horizontal dimension of building, measured in along wind direction, ft. (m)
    - θ : angle of plane of roof from horizontal, degrees

### INDEX

- GENERAL CONDITIONS**  
 A100 GENERAL NOTES & SCHEDULES
- ARCHITECTURAL PLANS**  
 A101 PLAN VIEW, SECTIONS/DETAILS & ELEVATION  
 A102 TYPICAL SLAB PLAN VIEW & SECTIONS  
 A103 ALTERNATE SLAB PLAN VIEW & SECTIONS

### FASTENER SCHEDULE

BOLT SIZE	LENGTH	WASHERS	QUANTITY	REMARKS
1/2"Ø	8-1/2"	YES	AS REQ'D	STEEL PLATE TO CONCRETE FOOTING
1"Ø	2"	YES	AS REQ'D	BEAMS TO COLUMN CONNECTION

### COMPONENT SCHEDULE - FOR BAY SPACING UP TO 10'-0"

ITEM	THICKNESS	SIZE	MAX LENGTH	FASTENERS	REMARKS
COL. 1	1/8"	4" X 4"	11'-0"	SHOP WELD STEEL BASE	
COL. 2	1/8"	4" X 4"	11'-0"	SHOP WELD STEEL BASE	
BM-1	1/8"	4" X 4"	10'-0"	1" DIA. X 2" (2) REQUIRED	FRONT & REAR BEAM
BM-2	1/8"	4" X 4"	10'-0"	1" DIA. X 2" (2) REQUIRED	CENTER CROSS BEAM
BM-3	1/8"	4" X 4"	9'-0"	1" DIA. X 2" (2) REQUIRED	
BM-3	1/8"	4" X 4"	10'-0"	1" DIA. X 2" (2) REQUIRED	
BM-4	1/8"	4" X 4"	7'-0"	1" DIA. X 2" (2) REQUIRED	
BM-4	1/8"	4" X 4"	8'-0"	1" DIA. X 2" (2) REQUIRED	
BM-4	3/16"	4" X 4"	9'-0"	1" DIA. X 2" (2) REQUIRED	
BM-4	1/4"	4" X 4"	10'-0"	1" DIA. X 2" (2) REQUIRED	
BASE PLATE	5/8"	10" X 10"	N/A	(4)-1/2"Ø X 8-1/2" WEDGE ANCHORS	ANCHOR TO CONCRETE FOOTING
Ⓛ1 SQUARE	22"	24" X 24"	N/A	SEE BASE PLATE ON SHT A101	(4) #5Ø ST REINF. RODS EA. WAY
Ⓛ2 SQUARE	22"	32" X 32"	N/A	SEE BASE PLATE ON SHT A101	(4) #5Ø ST REINF. RODS EA. WAY TOP & BOTTOM
Ⓛ1 ROUND	16"	36" DIA.	N/A	SEE BASE PLATE ON SHT A101	(4) #5Ø ST REINF. RODS EA. WAY
Ⓛ2 ROUND	36"	36" DIA.	N/A	SEE BASE PLATE ON SHT A101	(4) #5Ø ST REINF. RODS EA. WAY TOP & BOTTOM

### NOTES:

- SEE DETAILS FOR ATTACHMENT OF EACH SHOP WELDED BEAM CONNECTION.
- FOUNDATION AND REINFORCING SIZES ARE SUGGESTIONS ONLY. CONTRACTOR MUST VERIFY WITH LOCAL BUILDING CODE REQUIREMENTS PRIOR TO CONSTRUCTION.
- IF T1-11 OR PLYWOOD SHEATHING IS USED; USE ROOF FASTENERS #12 X 1-1/2" - 4" O.C. HWH SD METAL SCREWS W/ SEALING WASHERS
- NOTE: RECOMMEND A MINIMUM OF 12" FROM CENTER OF BASE PLATE TO EDGE OF SLAB ON ALL SIDES

### CONCRETE NOTES:

- FOOTINGS SHALL BEAR UPON UNDISTURBED TREATED SOIL OR SOIL COMPACTED TO AT LEAST 95% OF STANDARD PROCTOR MAXIMUM DRY DENSITY (ASTM D1557) FOR DEPTH OF AT LEAST THREE (3) FEET BELOW THE BOTTOM OF THE FOOTING.
- REINFORCING STEEL SHALL BE ASTM-A-615 GRADE 60 DEFORMED NEW BULLIT STEEL CONFORMING TO ACI-360, ACI-301, ACI-315, ACI-318 AND CRSI MANUAL OF STANDARD PRACTICE LATEST EDITIONS. MINIMUM LAP SPLICE SHALL BE 48 BAR DIAMETERS UNLESS NOTED OTHERWISE.
- ALL CONTINUOUS VERTICAL AND HORIZONTAL REINFORCING STEEL IN FOOTINGS. SHALL BE SPLICED A MINIMUM OF 48 BAR DIAMETERS OR 30" WHICHEVER IS GREATER.
- CONCRETE COVER OF REINFORCING STEEL SHALL BE AS FOLLOWS:
  - A. FOOTINGS: 3" BOTTOM AND SIDES, 2" TOP
  - B. BEAMS: 1-1/2" BOTTOM, SIDES AND TOP
  - C. COLUMNS: 1-1/2"
  - D. SLABS ON GRADE: 2" BOTTOM, 1" TOP.
  - E. OTHERS: PER ACTUAL
- FOUNDATION: 3,500 PSI @ 28 DAYS, TYPE II CONCRETE, 6 BAG. (MIN.) STONE FILL.
- FLOOR SLAB: 3,500 PSI @ 28 DAYS (4" THICK CONCRETE ON 6 MIL POLYETHYLENE VAPOR BARRIER ON 4" STONE FILL) MAX SLUMP = 5". TYPE II CONCRETE 6 BAG. (A) PROVIDE CUT JOINTS @ 100 SQ. FT. MAX IN SLABS
- ALL CONCRETE SLABS ON GRADE SHALL BE THE THICKNESS INDICATED ON THE DRAWINGS, OVER A 6 MIL POLYETHYLENE VAPOR BARRIER. SUCH SLABS SHALL BE REINFORCED WITH 6X6 - W2.9W2.9 WWM LAPPED 8" AT EDGES AND ENDS OR FIBER MESH REINFORCING.
- FILL UNDER CONCRETE SLAB WITH 4" (MIN.) FREE DRAINING AGGREGATE STONE FILL OVER COMPACTED SUB GRADE. FILL SHALL BE COMPACTED TO A DENSITY OF AT LEAST 95% OF STANDARD PROCTOR MAXIMUM DRY DENSITY (ASTM D1557.)
- WELDED WIRE MESH SHALL CONFORM TO ASTM-A-185, FREE FROM OIL, SCALE AND RUST AND PLACED IN ACCORDANCE WITH THE TYPICAL PLACE DETAILS OF ACI STANDARDS AND SPECIFICATIONS MINIMUM LAP SHALL BE ONE SPACE PLUS TWO (2) INCHES OR FIBERMESH.
- ALL TRANSITIONS BETWEEN NEW AND EXISTING CONCRETE SHALL HAVE 1/2" REFLEX RUBBER EXPANSION JOINTS OR EQUAL.

### SPECIFICATIONS:

- STEEL DUGOUT FRAME:
- HOLLOW STRUCTURAL SECTIONS (HSS) STEEL FRAMING SHALL BE FABRICATED FROM STEEL CONFORMING WITH ASTM A 500, GR. B. Fy = 46ksi
  - STEEL PLATES SHALL CONFORM WITH ASTM A36. Fy = 36ksi
  - FRAMES, BASE, AND WELDS ARE FABRICATED AND POWDER COATED AT THE FACTORY. NO WELDING IS DONE IN THE FIELD.
  - STEEL FRAME MEMBERS SHALL BE BLASTED TO NEAR WHITE METAL., CLEANED WITH AN 8-STAGE PRETREATMENT SYSTEM, AND ZINC RICH PRIMER COATED PRIOR TO THE FINISHED POWDER COAT PROCESS. POWDER COAT FINISH SHALL BE TGIC ELECTROSTATICALLY APPLIED POLYESTER POWDER.
  - FASTENERS SHALL BE 1" DIAMETER GRADE 5 BOLTS WITH FLAT WASHERS AND LOCKNUTS. BOLTS MEET ASME B18.2.1 WITH A MINIMUM TENSILE STRENGTH OF 120,000 PSI. ALL FASTENERS SHALL BE CONCEALED INSIDE THE TUBING.
  - ANCHORS SHALL BE 1/2" DIAMETER X 8-1/2" ZINC PLATED CONCRETE WEDGE ANCHORS.
  - OVERALL DIMENSIONS "SEE ATTACHED DRAWING"

### METAL ROOF PANELS:

GAUGE: ROOFING SHALL BE PRECUT 26 GA. MULTI RIB METAL ROOF PANEL UNLESS OTHERWISE NOTED

FASTENERS: FASTENERS SHALL BE COLOR MATCHED TO METAL ROOF COLOR AS SELECTED BY OWNER AND AS INDICATED ON PRODUCT APPROVAL

### WARRANTY:

DUGOUTS SHALL BE GUARANTEED AGAINST DEFECTS IN WORKMANSHIP OR MATERIAL FOR A PERIOD OF ONE YEAR FROM DATE OF INVOICE BY MANUFACTURER.

### COPYRIGHTS 2023 BY DUGOUTS USA

ALL DESIGNS AND ANY DERIVATIVE THEREOF ARE COPYRIGHTED BY DUGOUTS USA AND ARE THE SOLE PROPERTY OF DUGOUTS USA AND CANNOT BE USED BY ANYONE WITHOUT THE PERMISSION OF DUGOUTS USA. IN DOING SO YOU WOULD BE LIABLE FOR ANY LAWSUITS THAT RESULTED FROM THE USE OF THE DESIGN WITHOUT THE PERMISSION OF DUGOUTS USA.

### DUGOUTS USA

6565 W. NORVELL BRYANT HWY SUITE B  
 CRYSTAL RIVER, FLORIDA 34429  
 WWW.DUGOUTSUSA.COM  
 OFFICE: 352-527-7500  
 FAX: 352-527-7501

### MODEL#:

NOTE:  
 REFER TO MODEL # ABOVE AND SEE ATTACHED CORRESPONDING DRAWING FOR ACTUAL DUGOUT FRAME DETAILS AND DIMENSIONS

REVISIONS	DATE	DESCRIPTION

JOSEPH A. RISPOLI, AIA  
 ARCHITECT, FL. LICENSE: AR95439  
 DIGITAL SIGNATURE

**RISPOLI & ASSOCIATES**  
**ARCHITECTURE, INC.**  
 114 SOUTH MAGNOLIA AVENUE, OCALA, FLORIDA 34471  
 (352) 620-0909 WWW.RISPOLIARCHITECT.COM  
 JOE@RISPOLIARCHITECT.COM

PROJECT NAME: \_\_\_\_\_  
 PROJECT ADDRESS: \_\_\_\_\_  
**100% CONSTRUCTION DOCUMENTS**

DRAWN	PROJECT NO.
R A A	2439
CHECKED	DATE
R A A	10-03-24

**A100**  
 SHEET NO.

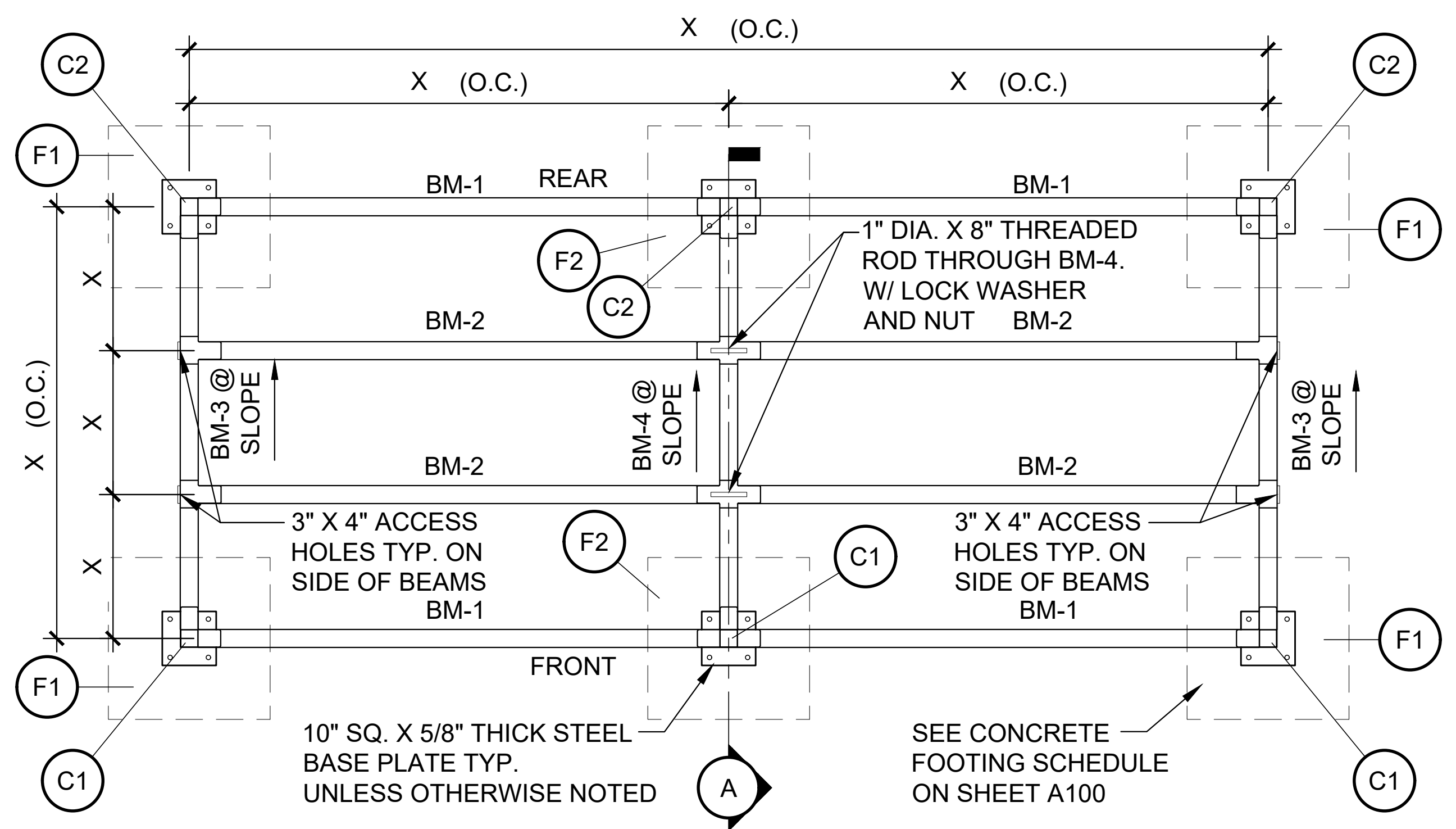

**COLUMN & BEAM PLAN**  
SCALE: 1/2" = 1'-0"

**NOTES:**

- SEE DETAILS FOR ATTACHMENT OF EACH SHOP WELDED BEAM CONNECTION.
- FOUNDATION AND REINFORCING SIZES ARE SUGGESTIONS ONLY. CONTRACTOR MUST VERIFY WITH LOCAL BUILDING CODE REQUIREMENTS PRIOR TO CONSTRUCTION.
- IF T1-11 OR PLYWOOD SHEATHING IS USED, USE ROOF FASTENERS #12 X 1-1/2" - 4" O.C. HWH SD METAL SCREWS W/ SEALING WASHERS.
- NOTE: RECOMMEND A MINIMUM OF 12" FROM CENTER OF BASE PLATE TO EDGE OF SLAB ON ALL SIDES.

\* NORTHERN CLIMATE DUGOUTS REQUIRE AN ADDITIONAL BM-2 FOR OVER 6'-0" DEPTH OR GREATER

X = AS PER SELECTED MODEL - REFERENCE COVER SHEET COMPONENT SCHEDULE AND VERIFY WITH SITE AND LOCAL CODE REQUIREMENTS.

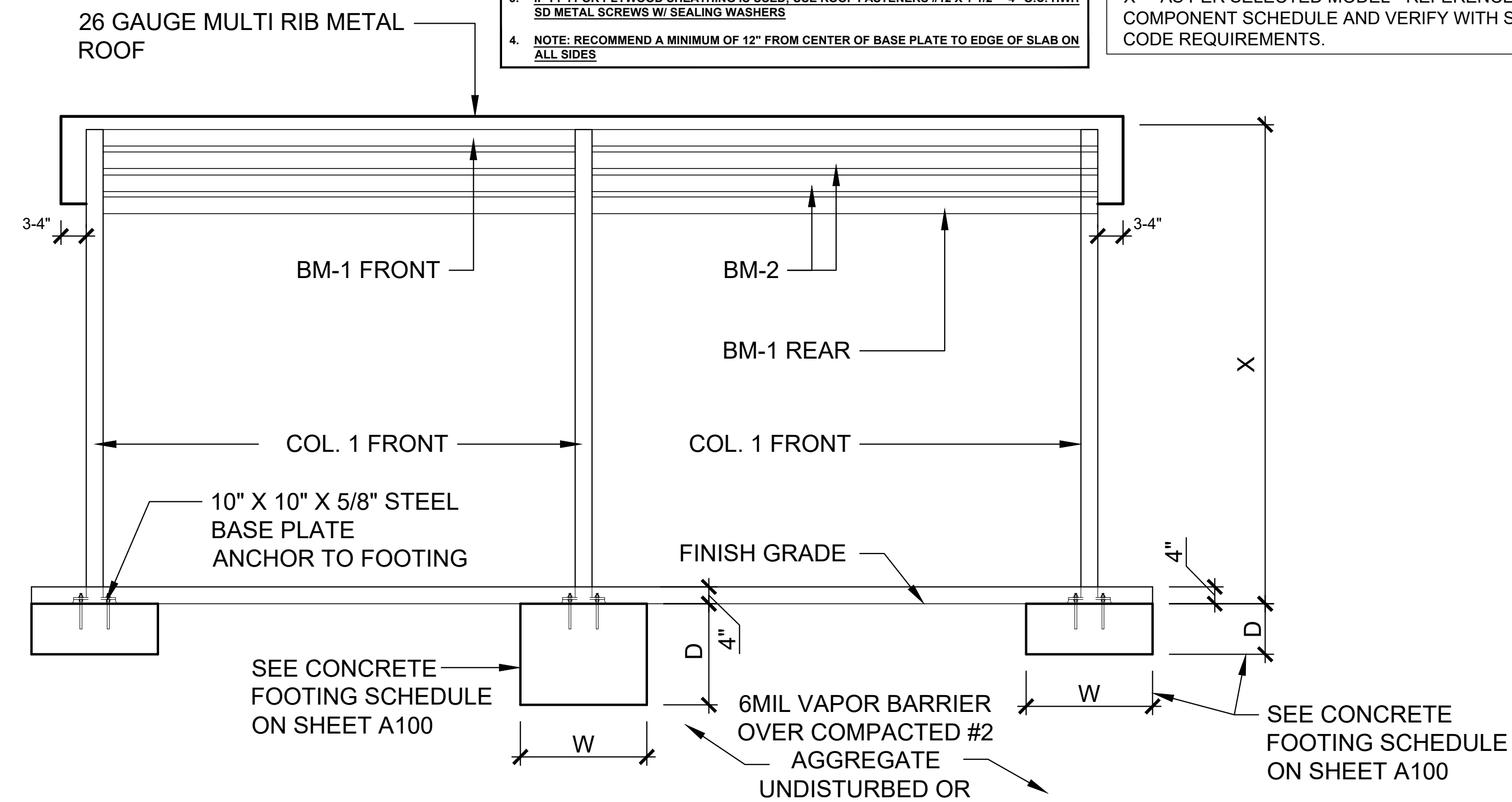

**FRONT ELEVATION**  
SCALE: 1/2" = 1'-0"

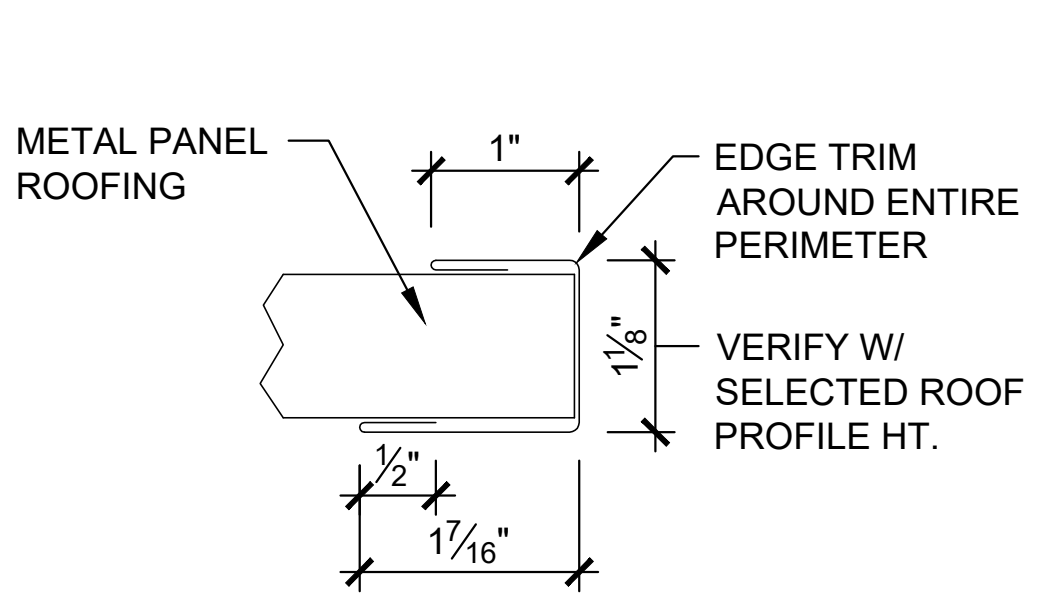

**TYPICAL EDGE TRIM DETAIL**  
SCALE: NTS

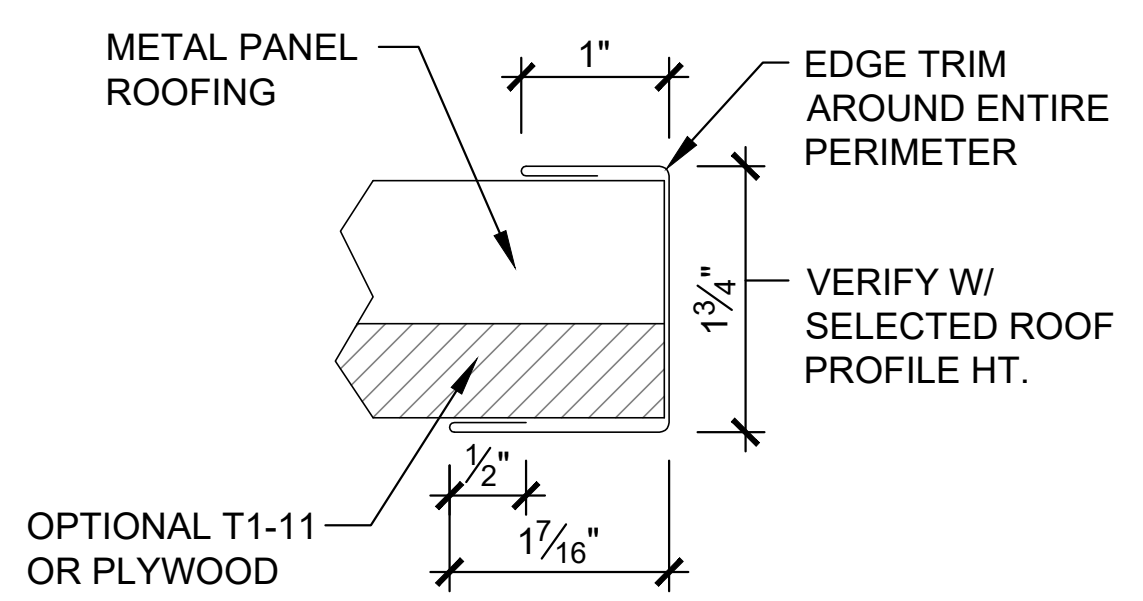

**OPTIONAL EDGE TRIM DETAIL**  
SCALE: NTS

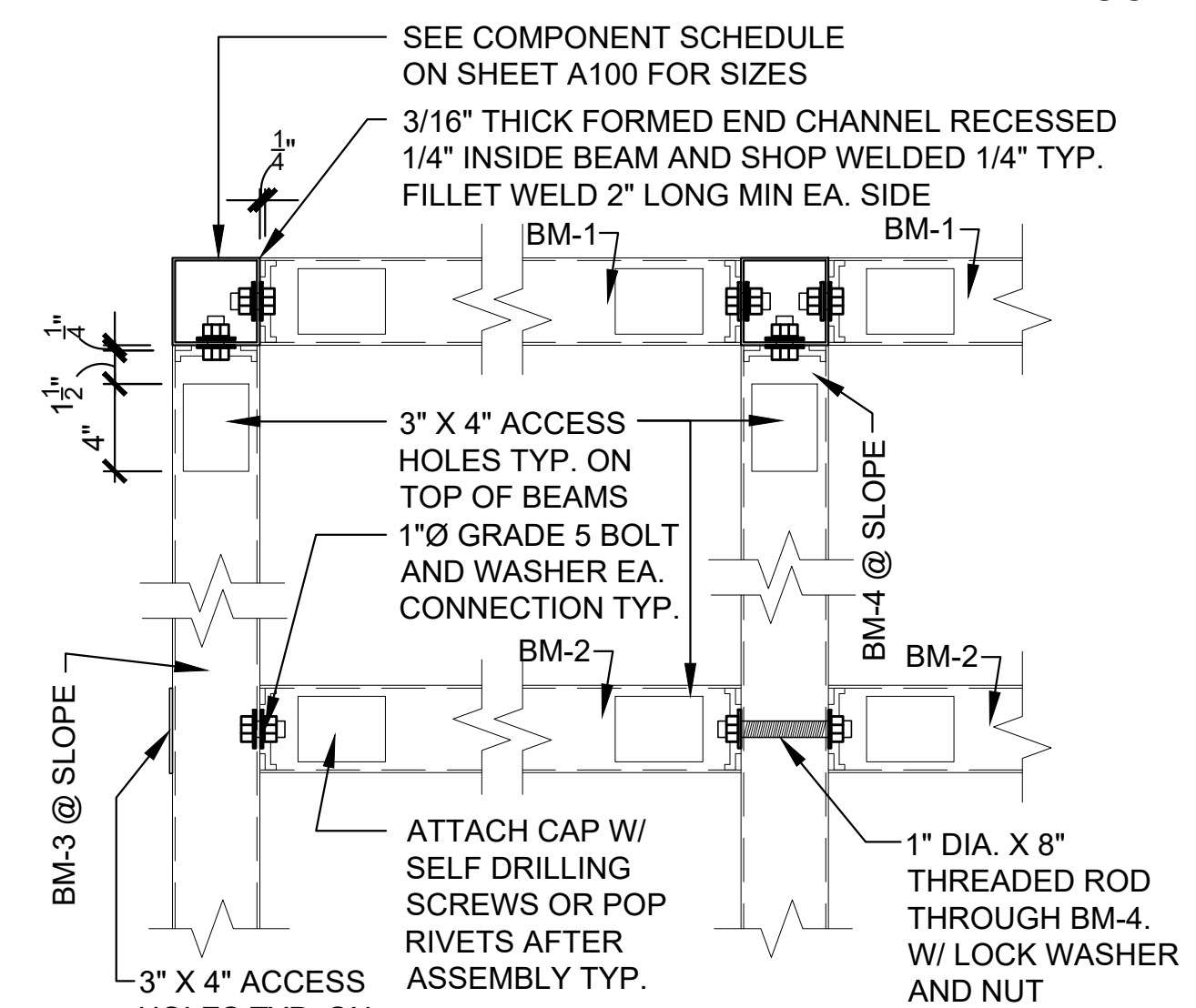

**STEEL BEAM FASTENING DETAIL**  
SCALE: 1-1/2" = 1'-0"

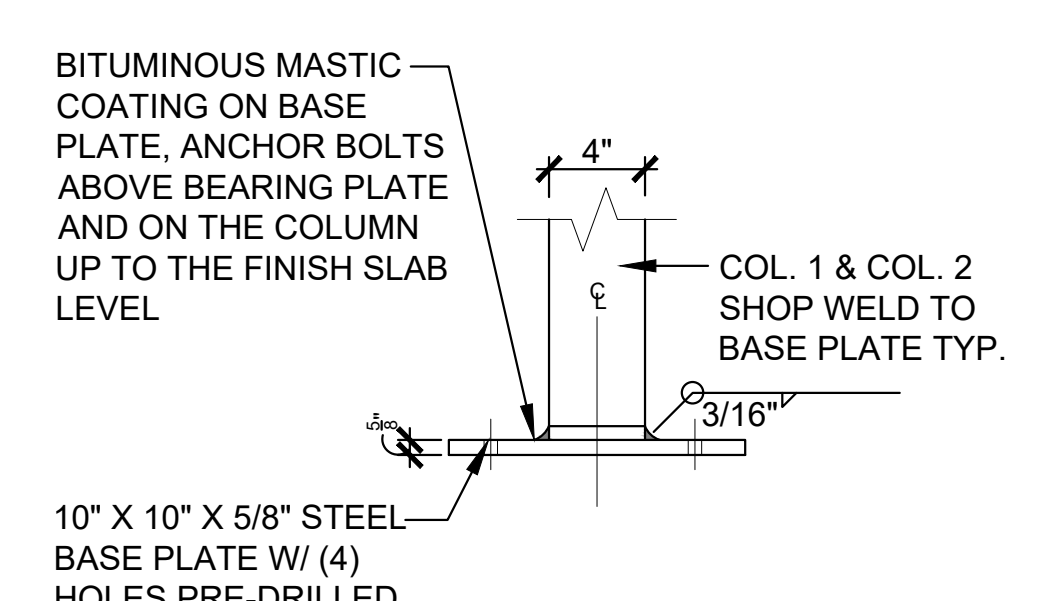

**BASE PLATE DETAIL SIDE VIEW**  
SCALE: 1-1/2" = 1'-0"

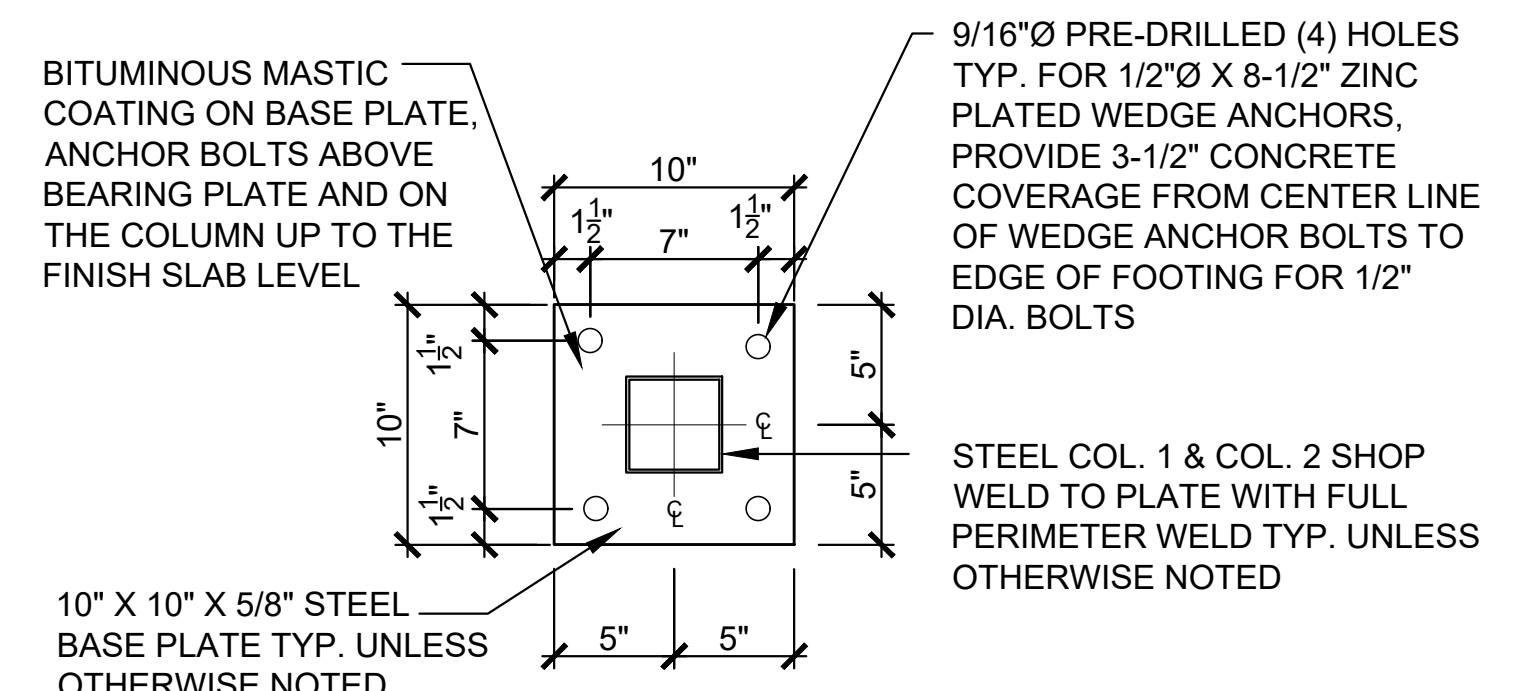

**BASE PLATE DETAIL PLAN VIEW**  
SCALE: 1-1/2" = 1'-0"

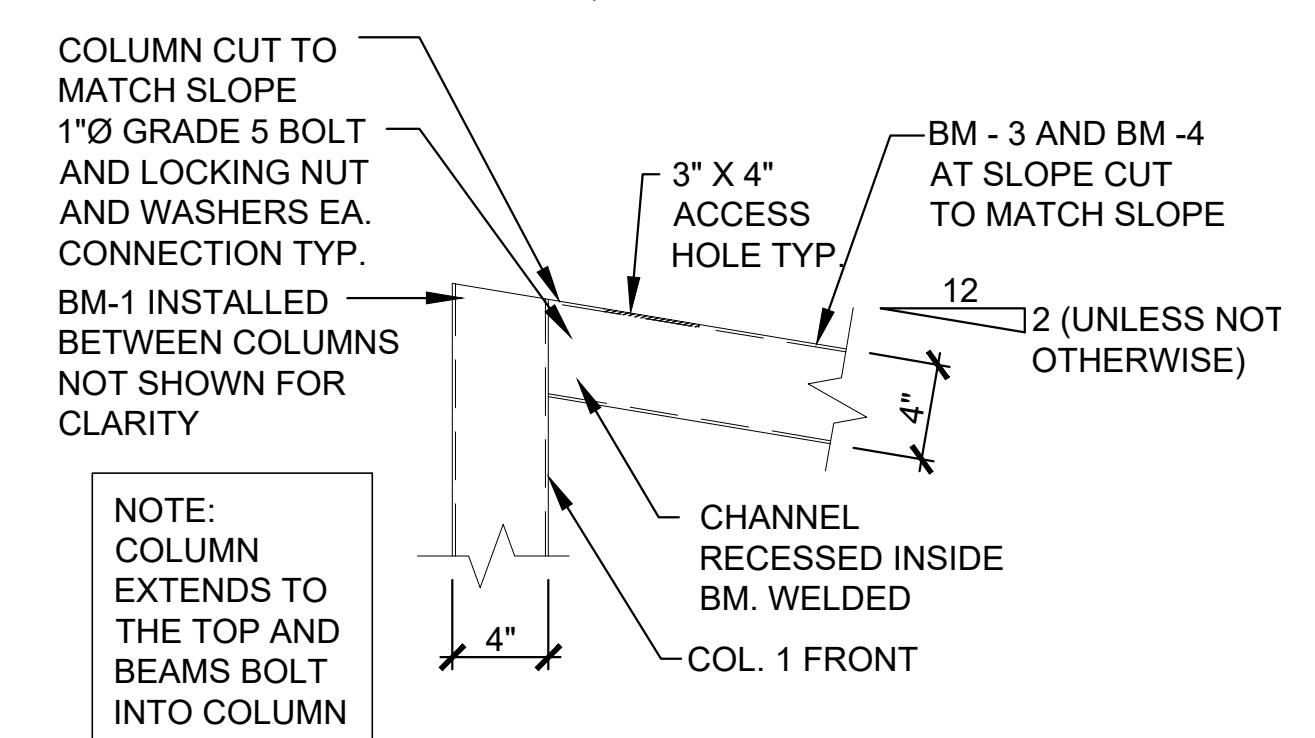

**BEAM TO COLUMN CONNECTION DETAIL**  
SCALE: 1-1/2" = 1'-0"

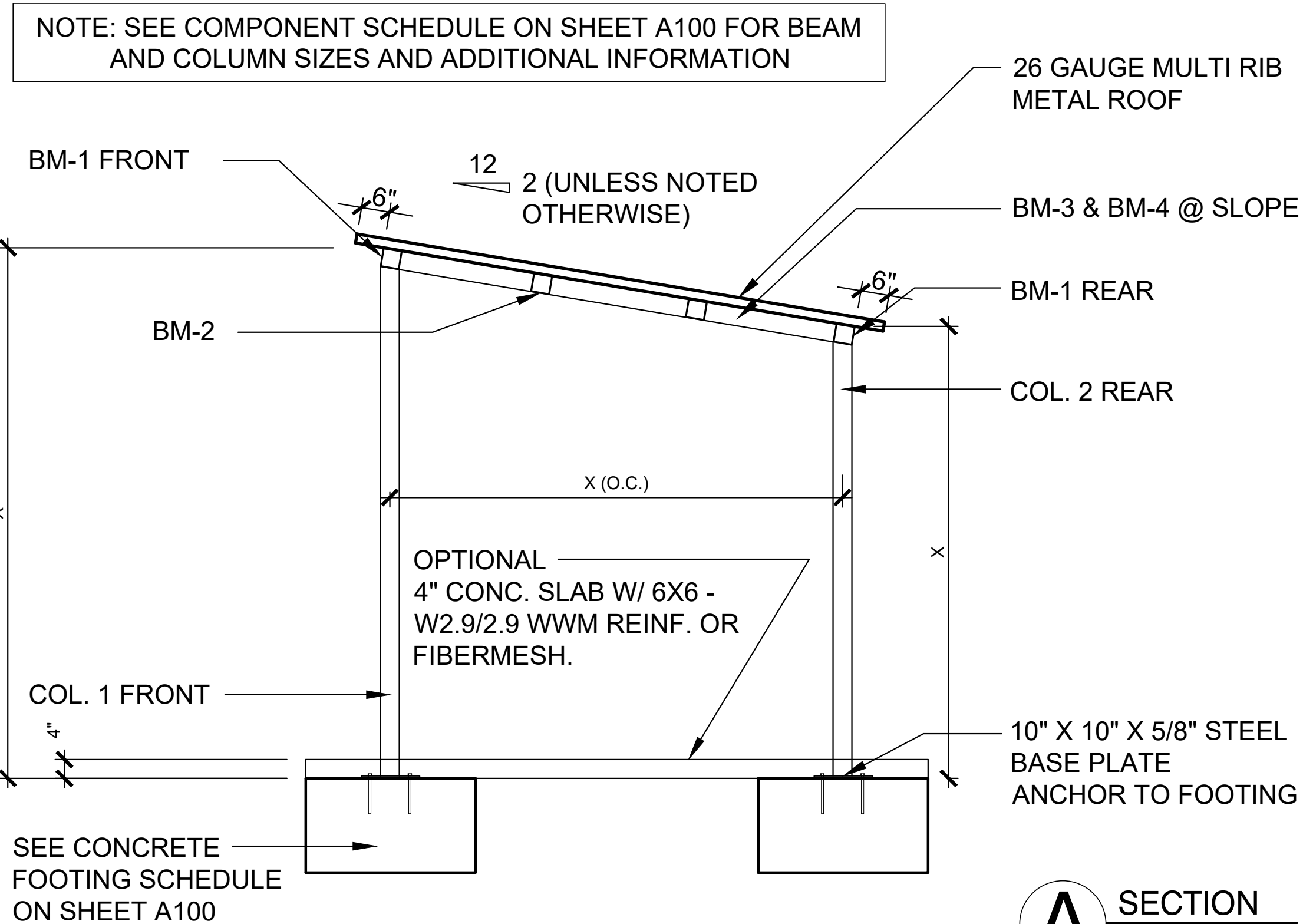

**A SECTION**  
SCALE: 1/2" = 1'-0"

REVISIONS	

JOSEPH A. RISPOLI, AIA  
ARCHITECT, FL. LICENSE: AR95439  
DIGITAL SIGNATURE

**RISPOLI & ASSOCIATES**  
**ARCHITECTURE, INC.**  
114 SOUTH MAGNOLIA AVENUE, OCALA, FLORIDA 34471  
(352) 620-0909 WWW.RISPOLIARCHITECT.COM  
JOE@RISPOLIARCHITECT.COM

PROJECT NAME: \_\_\_\_\_  
PROJECT ADDRESS: \_\_\_\_\_

DRAWN	PROJECT NO.
R A A	2439
CHECKED	DATE
R A A	10-03-24

**DUGOUTS USA**  
6565 W. NORVELL BRYANT HWY SUITE B  
CRYSTAL RIVER, FLORIDA 34429  
WWW.DUGOUTSUSA.COM  
OFFICE: 352-527-7500  
FAX: 352-527-7501

MODEL#: \_\_\_\_\_  
NOTE: REFER TO MODEL # ABOVE AND SEE ATTACHED CORRESPONDING DRAWING FOR ACTUAL DUGOUT FRAME DETAILS AND DIMENSIONS

**A101**  
SHEET NO.

**COPYRIGHTS 2023 BY DUGOUTS USA**  
ALL DESIGNS AND ANY DERIVATIVE THEREOF ARE COPYRIGHTED BY DUGOUTS USA AND ARE THE SOLE PROPERTY OF DUGOUTS USA AND CANNOT BE USED BY ANYONE WITHOUT THE PERMISSION OF DUGOUTS USA. IN DOING SO YOU WOULD BE LIABLE FOR ANY LAWSUITS THAT RESULTED FROM THE USE OF THE DESIGN WITHOUT THE PERMISSION OF DUGOUTS USA.

JOSEPH A. RISPOLI, AIA  
 ARCHITECT, FL. LICENSE: AR95439  
 DIGITAL SIGNATURE

**RISPOLI & ASSOCIATES**  
**ARCHITECTURE, INC.**  
 114 SOUTH MAGNOLIA AVENUE, OCALA, FLORIDA 34471  
 (352) 620-0909 WWW.RISPOLIARCHITECT.COM  
 JOE@RISPOLIARCHITECT.COM

PROJECT NAME: \_\_\_\_\_  
 PROJECT ADDRESS: \_\_\_\_\_  
**100% CONSTRUCTION DOCUMENTS**

DRAWN	PROJECT NO.
R A A	2439
CHECKED	DATE
R A A	10-03-24

MODEL#: \_\_\_\_\_  
 NOTE:  
 REFER TO MODEL # ABOVE AND SEE ATTACHED  
 CORRESPONDING DRAWING FOR ACTUAL DUGOUT FRAME  
 DETAILS AND DIMENSIONS

**A102**  
 SHEET NO.

- NOTES:**
- SEE DETAILS FOR ATTACHMENT OF EACH SHOP WELDED BEAM CONNECTION.
  - FOUNDATION AND REINFORCING SIZES ARE SUGGESTIONS ONLY. CONTRACTOR MUST VERIFY WITH LOCAL BUILDING CODE REQUIREMENTS PRIOR TO CONSTRUCTION.
  - IF T1-11 OR PLYWOOD SHEATHING IS USED; USE ROOF FASTENERS #12 X 1-1/2" - 4" O.C. HWH SD METAL SCREWS W/ SEALING WASHERS
  - NOTE: RECOMMEND A MINIMUM OF 12" FROM CENTER OF BASE PLATE TO EDGE OF SLAB ON ALL SIDES

X = AS PER SELECTED MODEL - REFERENCE COVER SHEET  
 COMPONENT SCHEDULE AND VERIFY WITH SITE AND LOCAL  
 CODE REQUIREMENTS.

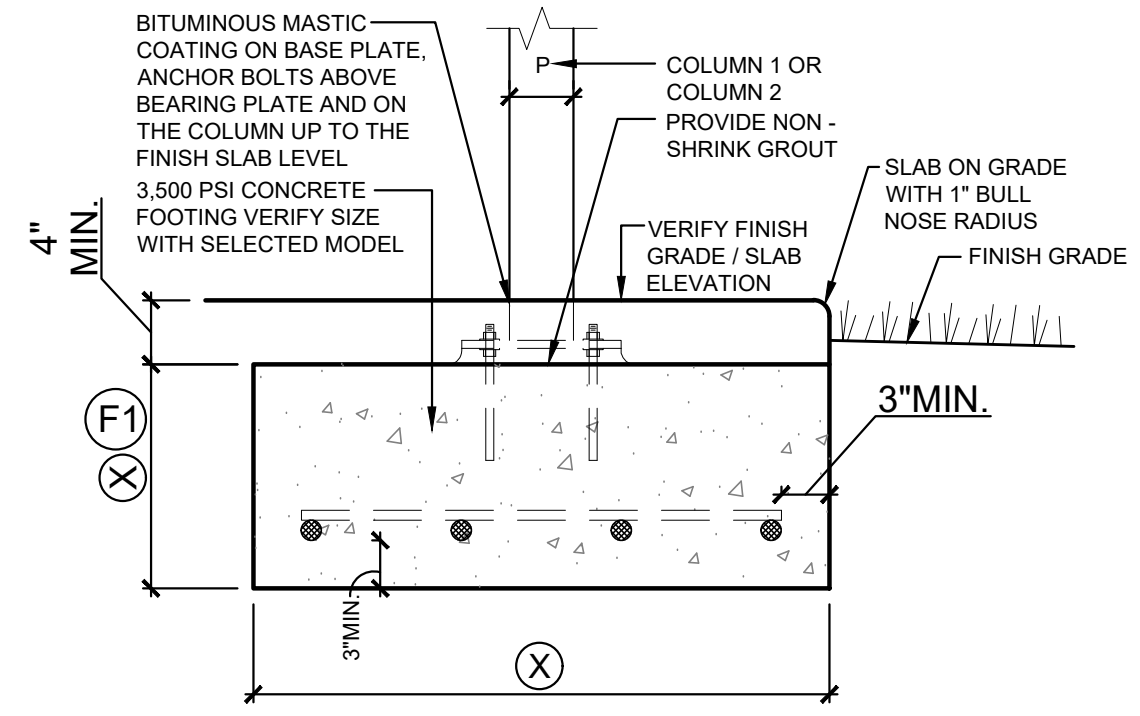

**1 SQUARE COLUMN FOOTING AND SLAB SECTION**  
 SCALE: 1" = 1'-0"

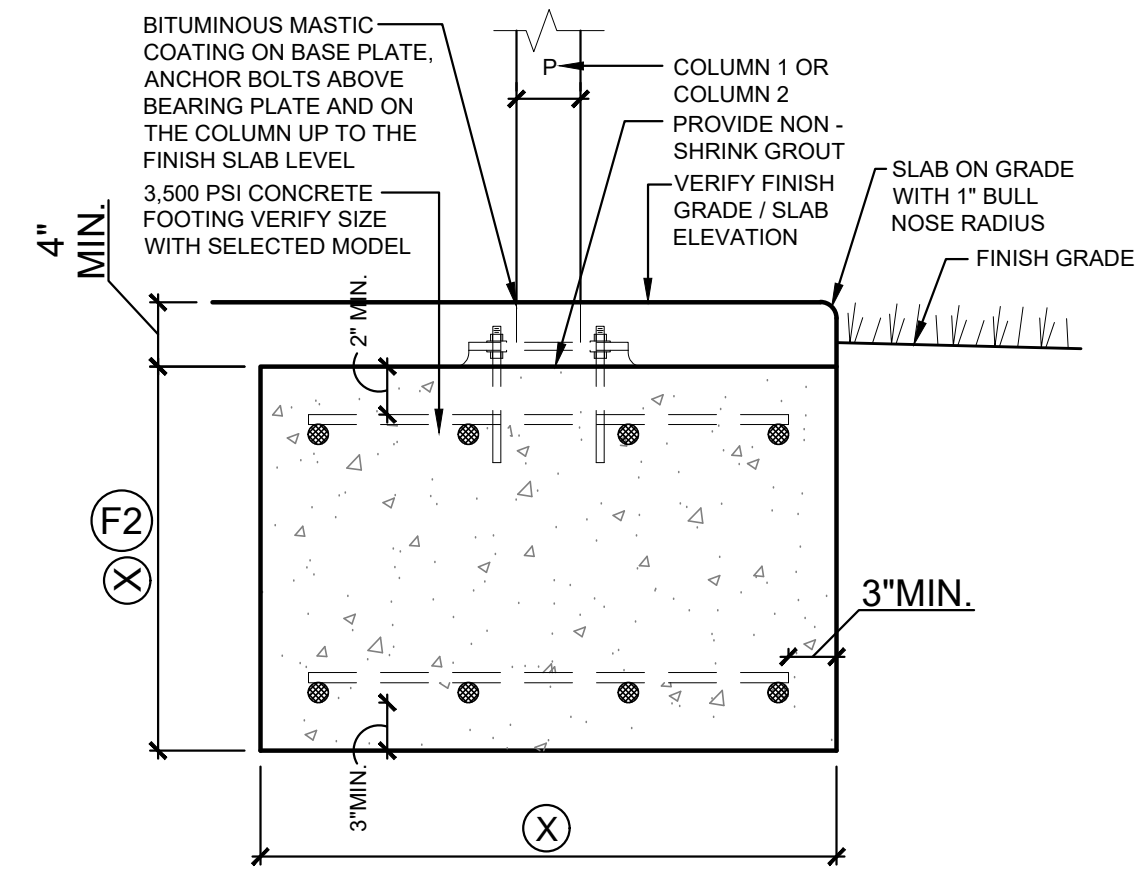

**2 SQUARE COLUMN FOOTING AND SLAB SECTION**  
 SCALE: 1" = 1'-0"

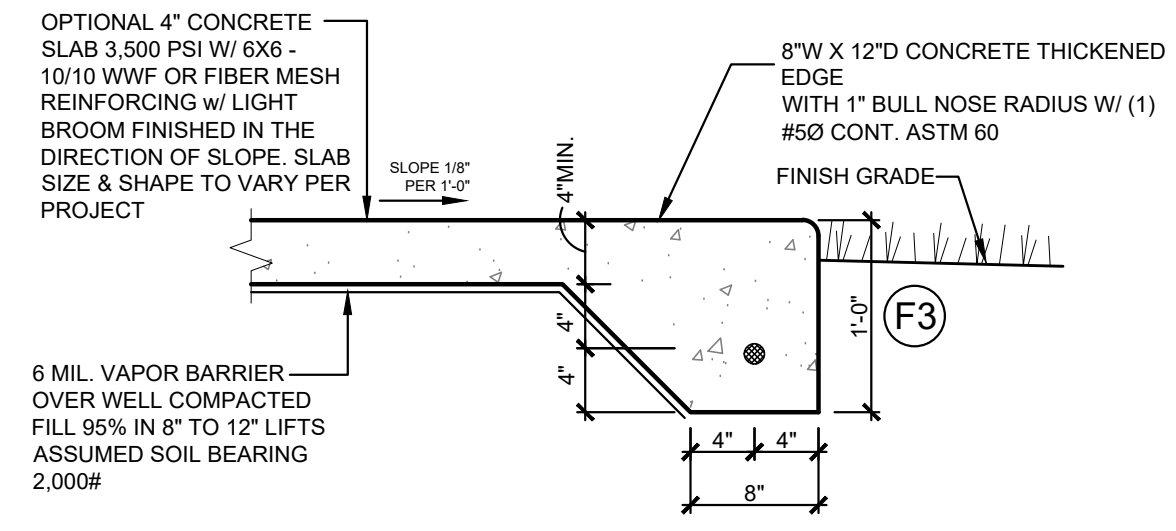

**3 THICKENED SLAB EDGE BETWEEN FOOTINGS**  
 SCALE: 1" = 1'-0"

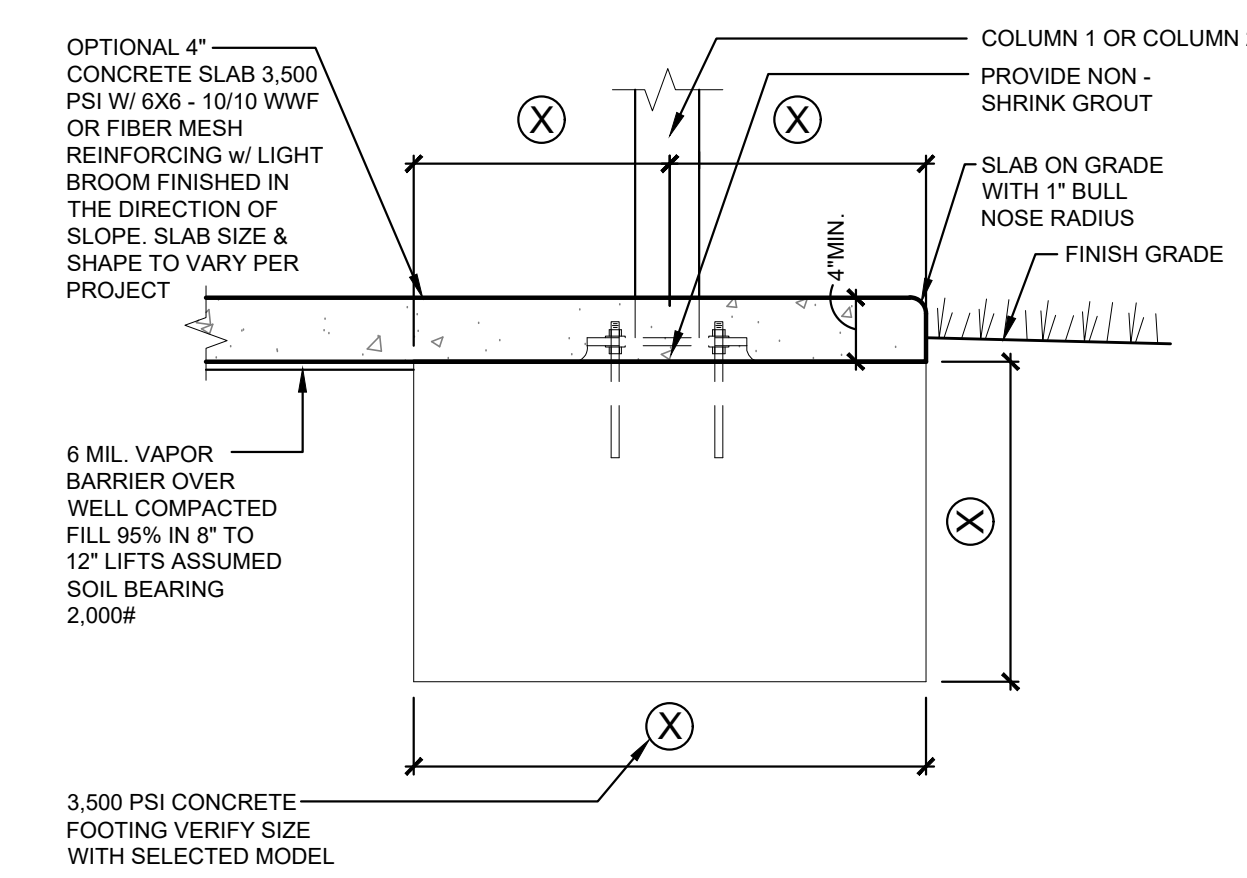

**4 SLAB OVER FOOTING DETAIL**  
 SCALE: NTS

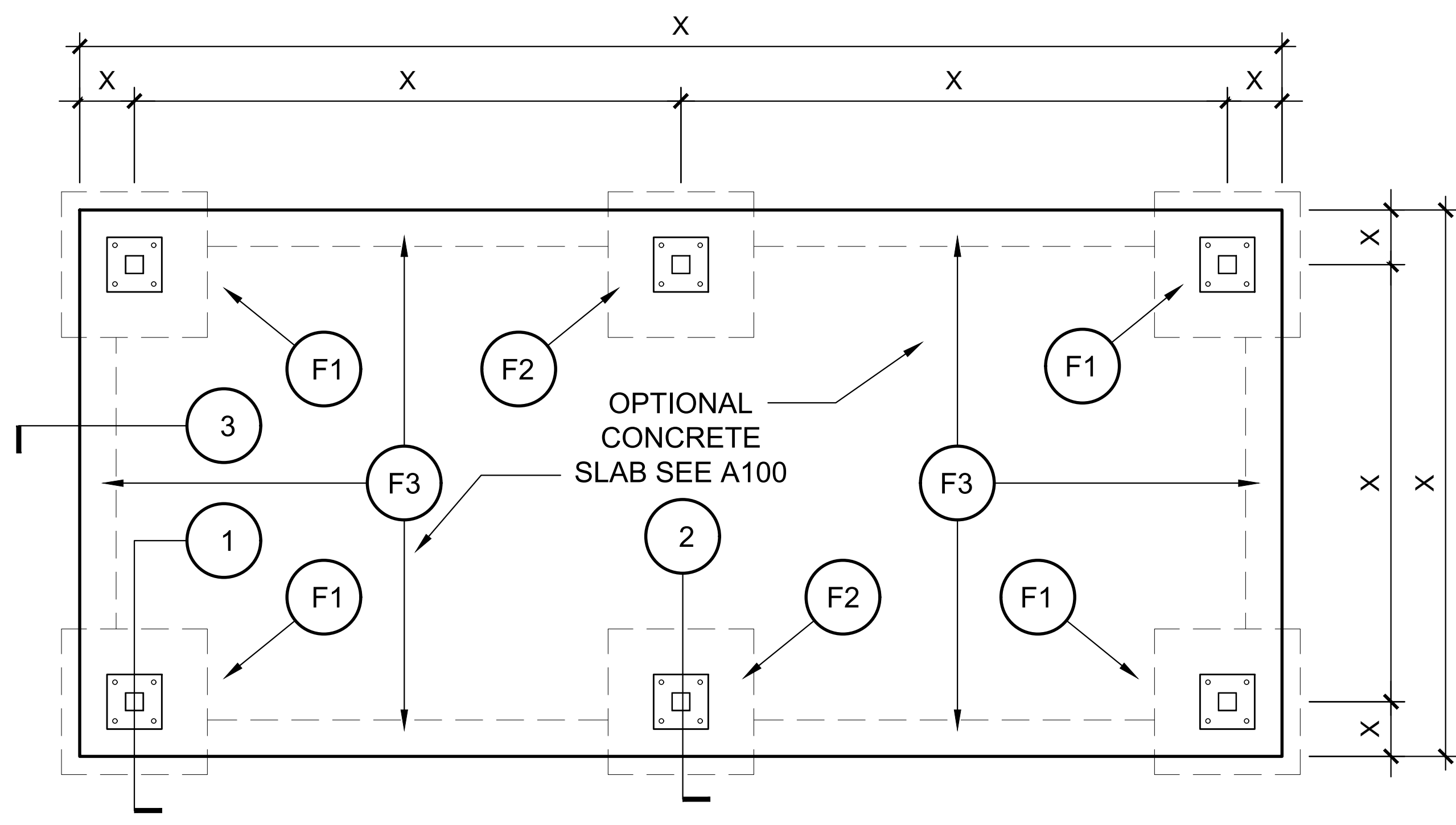

**SQUARE COLUMN SLAB PLAN VIEW**  
 SCALE: 1/2" = 1'-0"

**COPYRIGHTS 2023 BY DUGOUTS USA**

ALL DESIGNS AND ANY DERIVATIVE THEREOF ARE COPYRIGHTED BY DUGOUTS USA AND ARE THE SOLE PROPERTY OF DUGOUTS USA AND CANNOT BE USED BY ANYONE WITHOUT THE PERMISSION OF DUGOUTS USA. IN DOING SO YOU WOULD BE LIABLE FOR ANY LAWSUITS THAT RESULTED FROM THE USE OF THE DESIGN WITHOUT THE PERMISSION OF DUGOUTS USA.

**DUGOUTS USA**  
 6565 W. NORVELL BRYANT HWY SUITE B  
 CRYSTAL RIVER, FLORIDA 34429  
 WWW.DUGOUTSUSA.COM  
 OFFICE: 352-527-7500  
 FAX: 352-527-7501

JOSEPH A. RISPOLI, AIA  
 ARCHITECT, FL. LICENSE: AR95439  
 DIGITAL SIGNATURE

**RISPOLI & ASSOCIATES**  
**ARCHITECTURE, INC.**  
 114 SOUTH MAGNOLIA AVENUE, OCALA, FLORIDA 34471  
 (352) 620-0909 WWW.RISPOLIARCHITECT.COM  
 JOE@RISPOLIARCHITECT.COM

PROJECT NAME: \_\_\_\_\_  
 PROJECT ADDRESS: \_\_\_\_\_  
**100% CONSTRUCTION DOCUMENTS**

DRAWN	PROJECT NO.
R A A	2439
CHECKED	DATE
R A A	10-03-24

MODEL#: \_\_\_\_\_  
**A103**  
 SHEET NO.

X = AS PER SELECTED MODEL - REFERENCE COVER SHEET  
 COMPONENT SCHEDULE AND VERIFY WITH SITE AND LOCAL  
 CODE REQUIREMENTS.

- NOTES:**
- SEE DETAILS FOR ATTACHMENT OF EACH SHOP WELDED BEAM CONNECTION.
  - FOUNDATION AND REINFORCING SIZES ARE SUGGESTIONS ONLY. CONTRACTOR MUST VERIFY WITH LOCAL BUILDING CODE REQUIREMENTS PRIOR TO CONSTRUCTION.
  - IF T1-11 OR PLYWOOD SHEATHING IS USED; USE ROOF FASTENERS #12 X 1-1/2" - 4" O.C. HWH SD METAL SCREWS W/ SEALING WASHERS
  - NOTE: RECOMMEND A MINIMUM OF 12" FROM CENTER OF BASE PLATE TO EDGE OF SLAB ON ALL SIDES

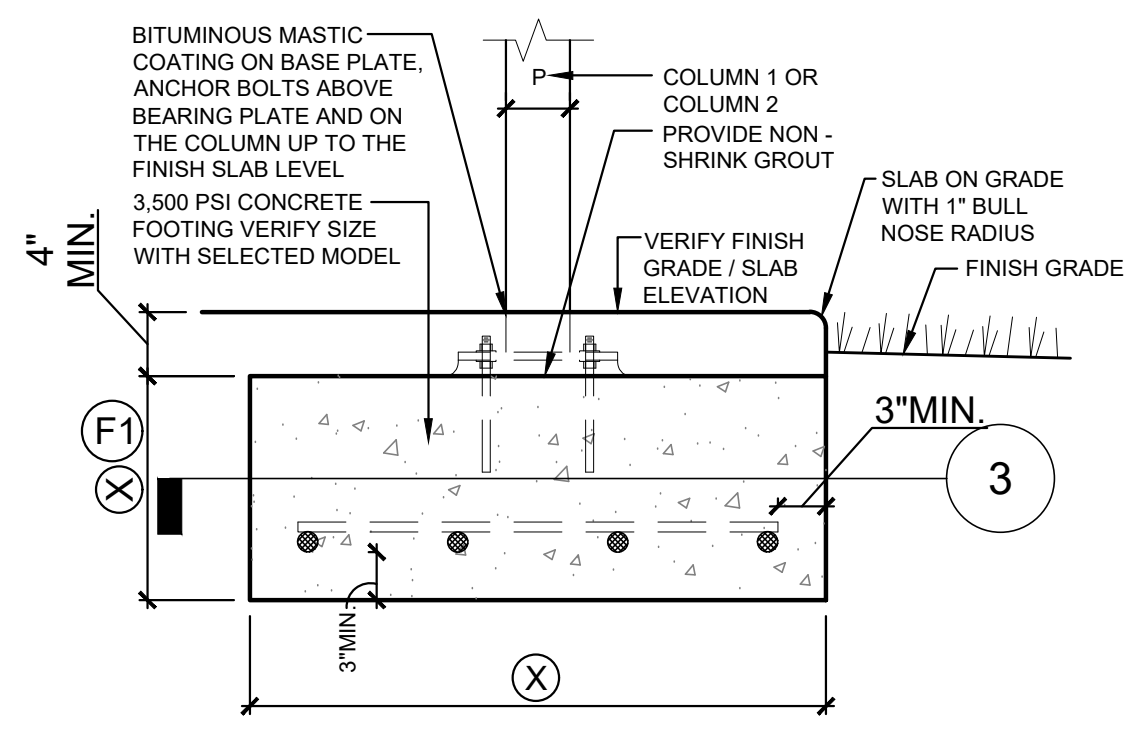

**1 ROUND COLUMN FOOTING AND SLAB SECTION**  
 SCALE: 1" = 1'-0"

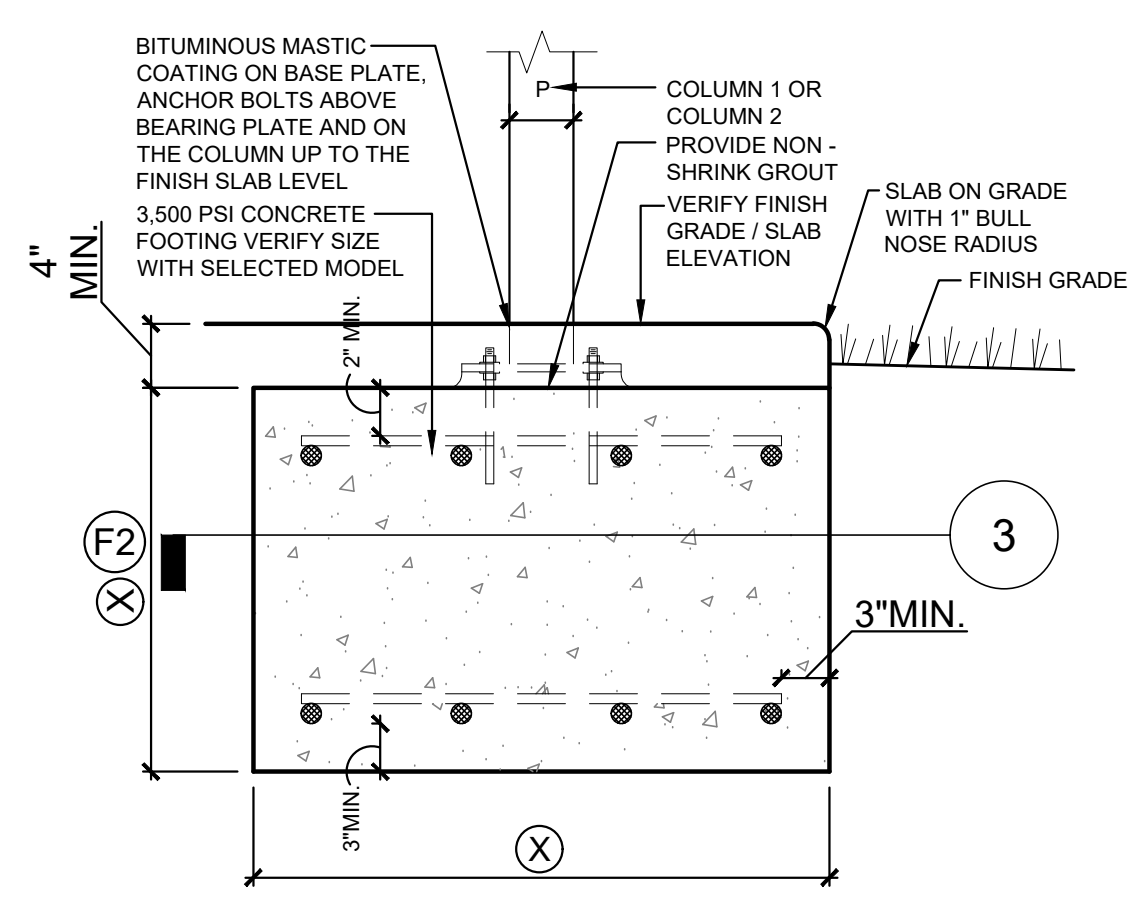

**2 ROUND COLUMN FOOTING AND SLAB SECTION**  
 SCALE: 1" = 1'-0"

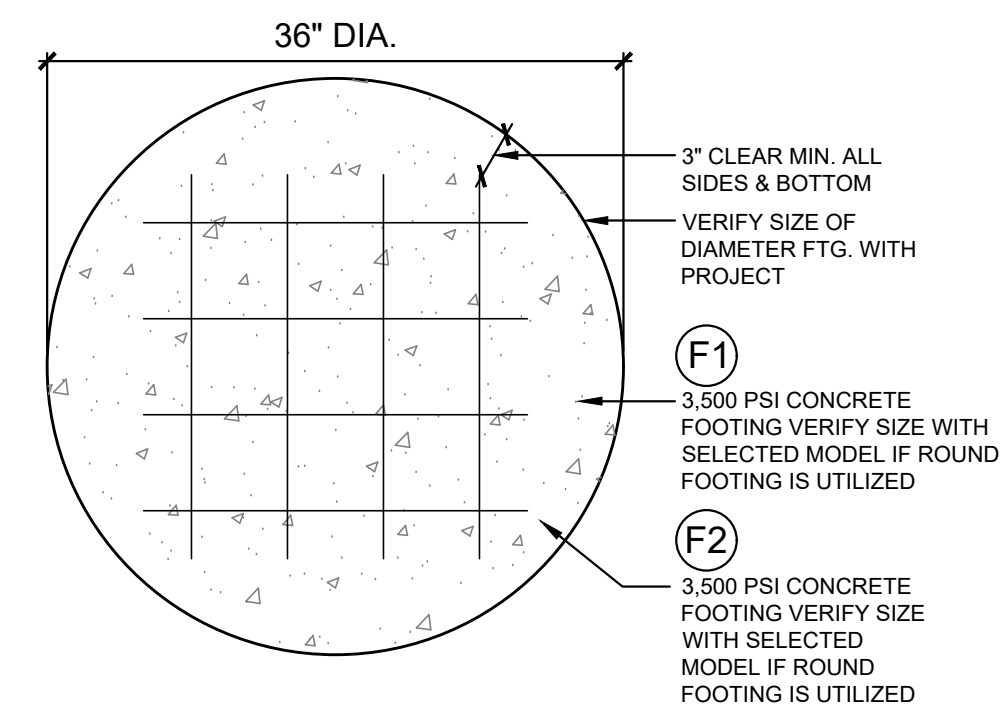

**3 ROUND COLUMN FOOTING AND SLAB SECTION**  
 SCALE: 1" = 1'-0"

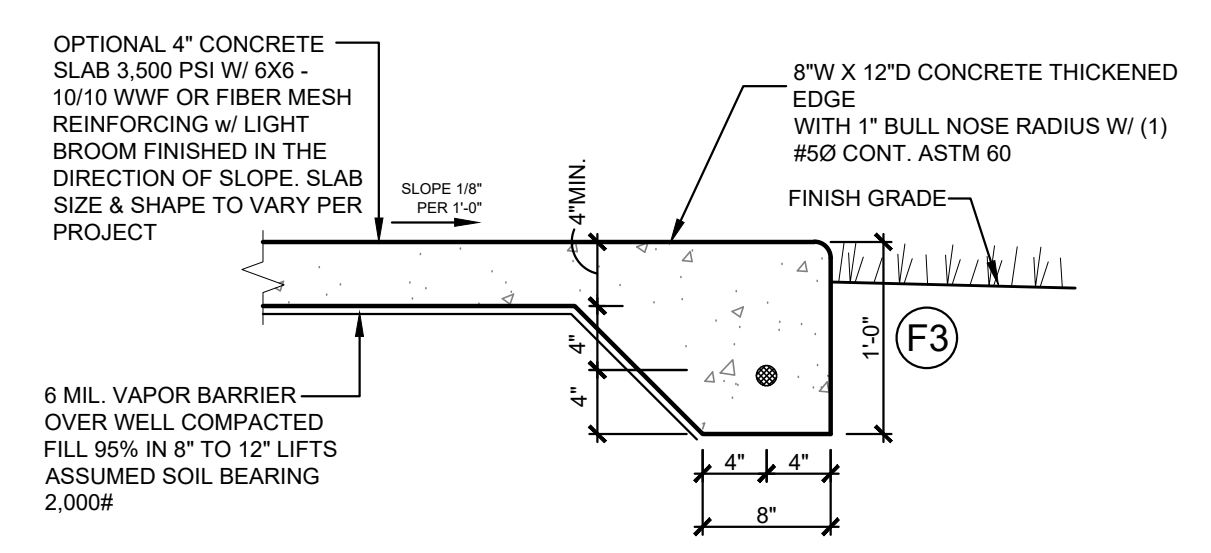

**4 THICKENED SLAB EDGE BETWEEN FOOTINGS**  
 SCALE: 1" = 1'-0"

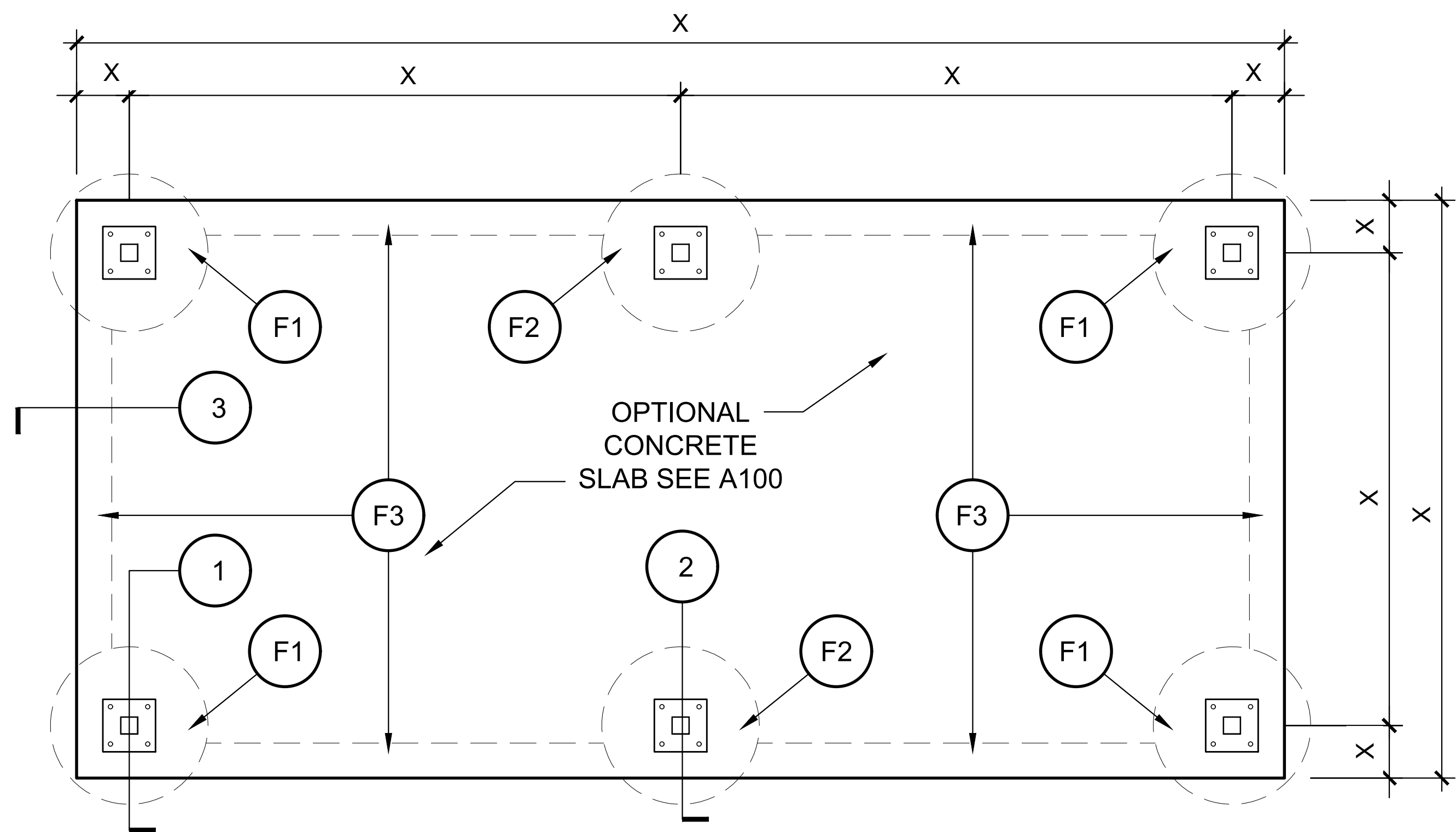

**5 SLAB OVER FOOTING DETAIL**  
 SCALE: NTS

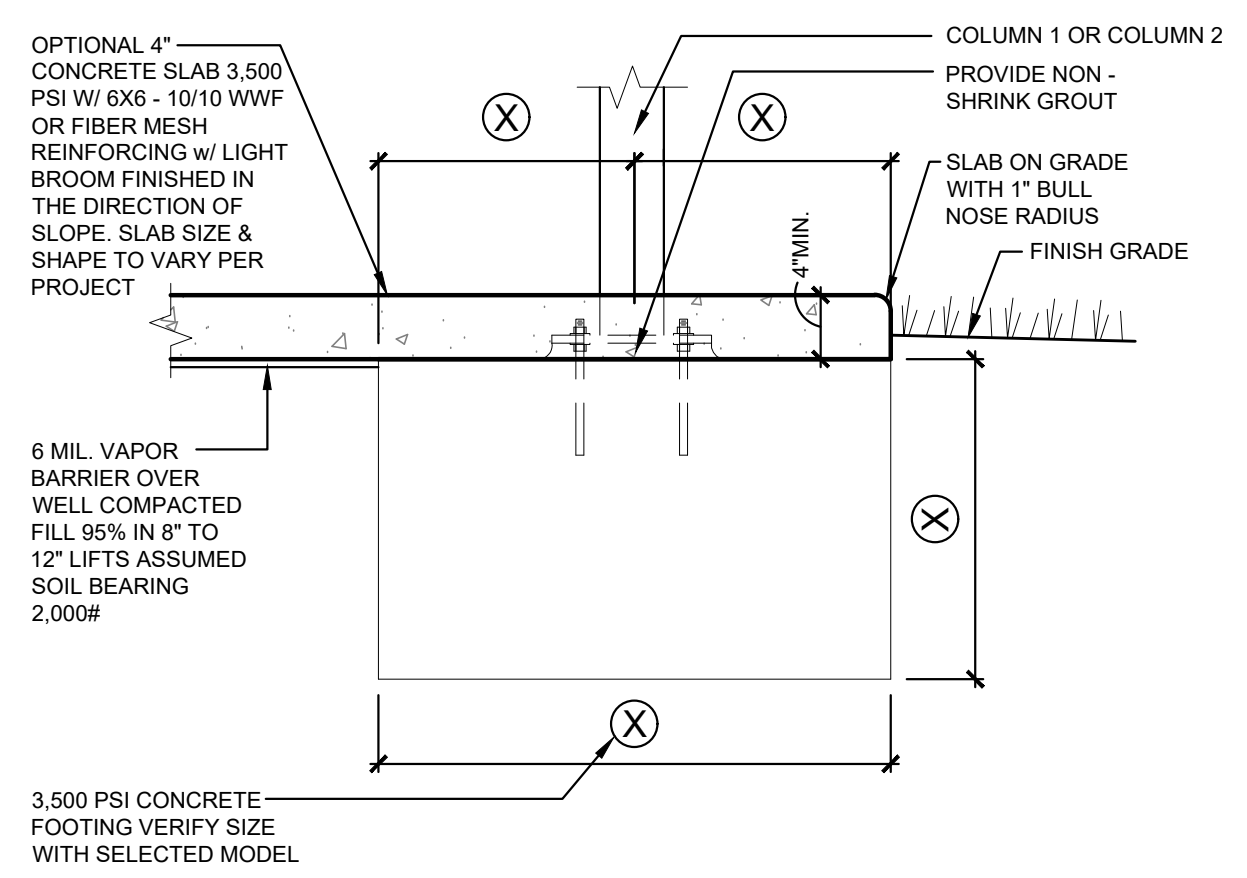

**COPYRIGHTS 2023 BY DUGOUTS USA**  
 ALL DESIGNS AND ANY DERIVATIVE THEREOF ARE COPYRIGHTED BY  
 DUGOUTS USA AND ARE THE SOLE PROPERTY OF DUGOUTS USA AND CANNOT BE USED BY  
 ANYONE WITHOUT THE PERMISSION OF DUGOUTS USA. IN DOING SO YOU WOULD BE LIABLE  
 FOR ANY LAWSUITS THAT RESULTED FROM THE USE OF THE DESIGN WITHOUT THE PERMISSION  
 OF DUGOUTS USA.

**DUGOUTS USA**  
 6565 W. NORVELL BRYANT HWY SUITE B  
 CRYSTAL RIVER, FLORIDA 34429  
 WWW.DUGOUTSUSA.COM  
 OFFICE: 352-527-7500  
 FAX: 352-527-7501

## Fencing



Vinyl Extruded chain link fence fabric has a steel core wire that is about 12 gauge. A heavier duty option would be extruded and bonded. This uses an 11 gauge core which after coating, finishes out at an 8 gauge finish. A last option which is special order would be fused and bonded. This is typically used in heavy commercial or industrial projects.

**What is the difference between 'Extruded' and 'Extruded and Bonded'?** In layman's terms, Extruded Vinyl, when cut with a knife, can be peeled off like a banana. However, it does not peel easily. Extruded and Bonded Vinyl is also adhered to the wire and would have to be cut off completely, much like peeling a potato. Extruded costs less than Extruded and Bonded.

**About mesh size:** The galvanized fabric mesh for 11-1/2 gauge measures 2-1/4". The 11, 9, and 6 gauge galvanized mesh measures 2". Mesh size is the measured distance between two parallel sides (see illustration).

### Measuring Chain Link Mesh

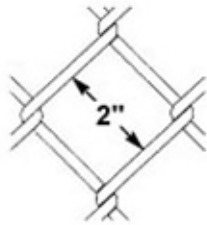

**Note about gauges:** The smaller the number, the heavier the fabric; henceforth 9ga. is heavier than 11ga.. We recommend 11ga. for residential jobs and 9ga. for commercial jobs. Heavier gauges are not only stronger, but have a better finish; The heavier the gauge the longer it may be 'hot-dip galvanized' to prevent rust and corrosion.

#### Fence Height

3'	53 lbs.
----	---------

3-1/2'	63 lbs.
4'	70 lbs.
5'	88 lbs.
6'	105 lbs.
7'	123 lbs.
8'	140 lbs.
10'	175 lbs.
12'	210 lbs.

*Weights shown are approximate.*

