



HISTORIC DISTRICT REVIEW BOARD REGULAR MEETING AGENDA

Herndon Council Chambers Building
765 Lynn Street, Herndon, VA 20170

Wednesday, January 21, 2026 | 7:00 PM

1. Call to Order

2. Organizational Meeting

- a. Election of Officers

3. Approval of Minutes

- a. October 1, 2025, Historic District Review Board Work Session Minutes
- b. October 15, 2025 Historic District Review Board Regular Meeting Minutes
- c. December 3, 2025, Historic District Review Board Work Session Minutes

4. Comments

- a. Comments from the Staff Members
- b. Comments from the Board Members
- c. Comments from Citizens

Members of the public may, for one 3-minute period, provide public comments, requests, consent or general item comments, and comments on matters not included on the agenda.

5. Public Hearings

- a. APPLICATION FOR NEW CONSTRUCTION, HDRB #25-005, 106 Monroe Hill Court, Herndon, Virginia, to consider an application for a Certificate of Appropriateness to construct a new accessory structure
- b. APPLICATION FOR AN ALTERATION, HDRB #25-011, 783 Station Street, Suite A, Herndon, Virginia, to consider a Certificate of Appropriateness to modify the front entrance of the building

6. Adjournment

Agenda Item: Election of Officers
Meeting Date: January 21, 2026
Category: Organizational Meeting
Prepared by: Amanda Kertz, Town Clerk

Description:

In accordance with the Historic District Review Board Bylaws and Herndon Town Code Section 78-150.4, the HDRB holds its election of officers annually at the first public hearing (regular meeting) of the Board in January. The Board will nominate and elect from its members a Chair and Vice Chair and designate a Secretary and Parliamentarian for one-year terms at the January 21, 2026, HDRB regular meeting.

Background/Timing Impact:

N/A

Fiscal Impact:

N/A

Legal Impact:

Elections held in accordance with Historic District Review Board Bylaws and Herndon Town Code Section 78-150.4.

Staff Recommendation/Next Steps:

Staff recommends the Board nominate and elect from its members a Chair and Vice Chair and designate a Secretary and Parliamentarian for one-year terms.

Attachments:

1. Resolution (Proposed)

**TOWN OF HERNDON, VIRGINIA
HISTORIC DISTRICT REVIEW BOARD**

RESOLUTION

JANUARY 21, 2026

Resolution - to elect the Officers and designate the Parliamentarian and Secretary of the Historic District Review Board.

BE IT RESOLVED by the Historic District Review Board of the Town of Herndon, Virginia that:

1. _____ is elected Chair for a one-year term effective January 21, 2026.
2. _____ is elected Vice Chair for a one-year term effective January 21, 2026.
3. The Town Clerk or their designee is designated Secretary for a one-year term effective January 21, 2026.
4. The Town Attorney or their designee is designated Parliamentarian for a one-year term effective January 21, 2026.

Motion:

Second:

Re: Chair of the Historic District Review Board

Action: _____ elected Chair of the Historic District Review Board

Votes

Ayes:

Nays:

Motion:

Second:

Re: Vice Chair of the Historic District Review Board

Action: _____ elected Vice Chair of the Historic District Review Board

Votes

Ayes:

Nays:

Motion:

Second:

Re: Secretary of the Historic District Review Board

26-HDRB-001

Action: The Town Clerk is designated Secretary of the Historic District Review Board

Votes

Ayes:

Nays:

Motion:

Second:

Re: Parliamentarian of the Historic District Review Board

Action: The Town Attorney is designated the Parliamentarian of the Historic District Review Board

Votes

Ayes:

Nays:

Agenda Item: October 1, 2025, Historic District Review Board Work Session Minutes

Meeting Date: January 21, 2026

Category: Approval of Minutes

Prepared by: Amanda Kertz, Town Clerk

Description:

This is a request to approve the October 1, 2025 Historic District Review Board Regular Meeting/Work Session Minutes.

Background/Timing Impact:

N/A

Fiscal Impact:

N/A

Legal Impact:

Code of Virginia Section 2.2-3707 outlines the requirements for the recording of minutes for all public bodies.

Staff Recommendation/Next Steps:

Recommend approval as presented.

Attachments:

1. 10.01.25 DRAFT HDRB WS Minutes

HERNDON HISTORIC DISTRICT REVIEW BOARD
Work Session Minutes
Wednesday, October 1, 2025

1. Call to Order

Chair Blaker-Glass called the October 1, 2025, Historic District Review Board work session to order at 7:04 p.m. in the Herndon Council Chambers Building, 765 Lynn Street, Herndon, Virginia. Board Members in attendance: Tamim Chowdhury, Melody Fetske, Paul LeReche, Amy Oleinick, Vice Chair Lauren Edmondson, and Chair Leslie Blaker-Glass.

Board Member Triston Chase O'Savio was absent.

Staff present during the meeting: Lauri Sigler, Deputy Town Attorney; Bryce Perry, Deputy Director of Community Development; Angelina Jones, Lead Planner; and Aaron Zoellick, Clerk of Boards and Commissions.

Chair Blaker-Glass determined there was a quorum with six members present.

2. Public Hearings

- a. APPLICATION FOR AN ALTERATION, HDRB #25-009, to consider an application for a Certificate of Appropriateness for alterations that include replacement siding, porch columns and railings, windows, entry doors, roof eaves, and asphalt shingle roofing at the single-family residential building located at 820 Locust Street, Herndon, Virginia**

Chair Blaker-Glass opened the review of the public hearing items and recognized Angelina Jones, Lead Planner, for the staff presentation.

Ms. Jones delivered the staff report and presentation dated October 1, 2025, and stated that staff is withholding a recommendation at this time.

There was discussion among the Board and staff on this item, including: (1) whether there is a significant list of changes that were made to the property in 1998; (2) clarification on the location of the historic windows on the property; (3) clarification on the replacement of the windows; and (4) clarification on the plan to shift the door.

Chair Blaker-Glass invited the applicants to provide comments.

The homeowner, Vanessa Dawn Lewis, and the applicant, Jason Slatinsky of Winn Design, were present and provided an overview of the project.

There was discussion among the Board, staff, and the applicant on this item, including: (1) concern that certain proposed elements could reflect newer Craftsman-style homes, rather than the historic character of the property; (2) clarification regarding compliance with Historic District Guidelines and identification of non-confirming features, including the proposed front façade window; (3) original architectural elements, including the column design and door placement, and recommendations for historically appropriate door styles and brackets; (4) desire to avoid a false historical narrative; (5) clarification on what materials are needed prior to the regular meeting; and (6) consideration of window and door changes, including potential impacts on the home's historic character.

b. APPLICATION FOR A DEMOLITION, HDRB #25-010, to consider an application for a Certificate of Appropriateness for the demolition of the existing detached garage located at 820 Locust Street, Herndon, Virginia

Chair Blaker-Glass recognized Angelina Jones, Lead Planner, for the staff report.

Ms. Jones delivered the staff report and staff presentation dated October 1, 2025, and stated that staff is withholding a recommendation pending provision of additional information.

There was discussion among the Board and staff on this item, including: (1) whether replacement in-kind is a sufficient concession; (2) clarification regarding staff's confidence in the garage's circa-1925 construction date; (3) possible safety concerns, including asbestos abatement requirements; (4) structural integrity concerns; and (5) clarification as to why demolition and replacement cannot be considered under one application.

Chair Blaker-Glass invited the applicants to provide comments.

The homeowner, Vanessa Dawn Lewis, and the applicant, Jason Slatinsky of Winn Design, were present and provided brief comments.

There was discussion among the Board, staff, and the applicants on this item, including: (1) the applicant's intent to remove the existing garage, and the timing of its removal; (2) use of the garage area as a staging area during the main structure's renovation; (3) whether the structure is a contributing structure in the Historic District; (4) if a hypothetical historic structure destroyed by fire would be required to be replaced "as is"; (5) if the demolition is approved, whether the Board can require complete documentation of the existing structure; and (6) how the Board would evaluate an application proposing replacement with a structure identical to the existing one.

Lauri Sigler, Deputy Town Attorney, stated that the Board must review any application for the new garage.

3. New Business

a. Resolution to support a Zoning Ordinance Text Amendment (ZOTA) to clarify and improve the existing process of the Historic District Review Board to grant setback reductions within the Historic District Overlay

Chair Blaker-Glass called on Angelina Jones, Lead Planner, to present the item.

Ms. Jones delivered the staff report and reviewed Sec. 78-60.3 of the Town of Herndon's Zoning Ordinance, which was relevant to the proposed resolution.

There was discussion among the Board and staff on this item, including: (1) clarification on the Zoning Ordinance Text Amendment; and (2) origin of the 20-foot setback limit.

4. Comments

a. Comments from the Staff Members

Angelina Jones, Lead Planner, stated that there was an upcoming training in Stafford County on November 14.

Lauri Sigler, Deputy Town Attorney, provided information about remote participation in meetings.

b. Comments from the Board Members

No comments were offered.

5. Adjournment

There being no further business, and without objection, Chair Blaker-Glass adjourned the Historic District Review Board work session at 9:02 p.m.

Amanda E.M. Kertz
Town Clerk

Minutes approved by Historic District Review Board: _____

Agenda Item: October 15, 2025 Historic District Review Board Regular Meeting Minutes

Meeting Date: January 21, 2026

Category: Approval of Minutes

Prepared by:

Description:

This is a request to approve the October 15, 2025 Historic District Review Board Regular Meeting Minutes.

Background/Timing Impact:

N/A

Fiscal Impact:

N/A

Legal Impact:

Code of Virginia Section 2.2-3707 outlines the requirements for the recording of minutes for all public bodies.

Staff Recommendation/Next Steps:

Recommend approval as presented.

Attachments:

1. October 15, 2025, HDRB Draft Regular Meeting Minutes



HERNDON HISTORIC DISTRICT REVIEW BOARD
Regular Meeting Minutes
Wednesday, October 15, 2025

1. Call to Order

Vice Chair Edmondson called the October 15, 2025, Historic District Review Board regular meeting to order at 7:00 p.m. in the Herndon Council Chambers, 765 Lynn Street, Herndon, Virginia. Board Members in attendance: Tamim Chowdhury, Melody Fetske, Paul LeReche, Amy Oleinick, Triston Chase O'Savio, and Vice Chair Lauren Edmondson.

Chair Leslie Blaker-Glass was absent.

Staff present during the meeting: Lauri Sigler, Deputy Town Attorney; Angelina Jones, Lead Planner; and Aaron Zoellick, Clerk of Boards and Commissions.

Vice Chair Edmondson determined there was a quorum with six members present.

2. Approval of Minutes

a. September 17, 2025, Historic District Review Board Regular Meeting Minutes

Board Member Fetske motioned to approve the minutes from the September 17, 2025, Historic District Review Board regular meeting. The motion was seconded by Board Member Oleinick. The question was called on the motion, which was approved by a 6-0 roll call vote. Board Members Chowdhury, Fetske, LeReche, Oleinick, O'Savio, and Vice Chair Edmondson voted "Aye." Chair Leslie Blaker-Glass was absent.

3. Comments

a. Comments from the Staff Members

Angelina Jones, Lead Planner, provided an update about the November HDRB and ARB meeting dates.

Ms. Jones provided an update on the headstone cleaning event and an update on the Harvest event at Frying Pan Park.

b. Comments from the Board Members

No comments were offered.

c. Comments from Citizens

No comments were offered.

4. Public Hearings

- a. **APPLICATION FOR AN ALTERATION, HDRB #25-009, to consider an application for a Certificate of Appropriateness for alterations that include replacement siding, porch columns and railings, windows, entry doors, roof eaves, and asphalt shingle roofing at the single-family residential building located at 820 Locust Street, Herndon, Virginia**

Certificates of Publication were filed from the Editor of the *Fairfax County Times* Newspapers, showing that notice of said public hearing items had been duly advertised in the September 26 and October 3, 2025, issues.

Vice Chair Edmondson opened the public hearing and called on Angelina Jones, Lead Planner, for the staff presentation.

Ms. Jones delivered the staff presentation dated October 15, 2025, which is on file with the Department of Community Development. Staff is recommending approval of HDRB #25-009.

There was discussion among the Board Members and staff on this item, including: (1) appreciation for the presentation and images provided by the architect to envision the project; and (2) clarification on the front elevation.

Vice Chair Edmondson invited the applicant to provide comment.

The applicant was present but did not provide comments.

No members of the public were present.

Vice Chair Edmondson closed the public hearing and moved to the board level for discussion and possible action.

Board Member Fetske motioned to approve HDRB #25-009 in accordance with the proposed resolution. The motion was seconded by Board Member Chowdhury. The question was called on the motion, which was approved by a 6-0 roll call vote. Board Members Chowdhury, Fetske, LeReche, Oleinick, O'Savio, and Vice Chair Edmondson voted "Aye." Chair Leslie Blaker-Glass was absent.

Vice Chair Edmondson advised the applicant to inform staff if there are any changes to the plan or materials.

- b. **APPLICATION FOR A DEMOLITION, HDRB #25-010, to consider an application for a Certificate of Appropriateness for the demolition of the existing detached garage located at 820 Locust Street, Herndon, Virginia**

Certificates of Publication were filed from the Editor of the *Fairfax County Times* Newspapers, showing that notice of said public hearing items had been duly advertised in the September 26 and October 3, 2025, issues.

Vice Chair Edmondson opened the public hearing and called on Angelina Jones, Lead Planner, for the staff presentation.

Ms. Jones delivered the staff presentation dated October 15, 2025, which is on file with the Department of Community Development. Staff is recommending approval of HDRB #25-010 in accordance with the proposed resolution.

There was discussion among Board Members and staff on this item, including: (1) concern regarding demolition involving asbestos materials; and (2) clarification on the distinction between condition and integrity.

Vice Chair Edmondson invited the applicant to provide comment.

The applicant was present but did not provide comment.

No members of the public were present.

Vice Chair Edmondson closed the public hearing and moved to the board level for discussion and possible action.

Board Member Fetske motioned to approve HDRB #25-010 in accordance with the proposed resolution. The motion was seconded by Board Member Oleinick. The question was called on the motion, which was approved by a 6-0 roll call vote. Board Members Chowdhury, Fetske, LeReche, Oleinick, O'Savio, and Vice Chair Edmondson voted "Aye." Chair Leslie Blaker-Glass was absent.

5. New Business

a. Resolution to establish the Historic District Review Board meeting schedule for January 1, 2026, to December 31, 2026

Vice Chair Edmondson called on Ms. Sigler for an update on the 2026 Historic District Review Board meeting schedule. She provided an update on the 2026 Historic District Review Board meeting schedule.

Vice Chair Edmondson moved to the board level for discussion and possible action.

Board Member Fetske motioned to approve the 2026 Historic District Review Board meeting schedule in accordance with the proposed resolution. The motion was seconded by Board Member Oleinick. The question was called on the motion, which was approved by a 6-0 roll call vote. Board Members Chowdhury, Fetske,

LeReche, Oleinick, O'Savio, and Vice Chair Edmondson voted "Aye." Chair Leslie Blaker-Glass was absent.

b. Resolution to support a Zoning Ordinance Text Amendment (ZOTA) to clarify and improve the existing process of the Historic District Review Board to grant setback reductions within the Historic District Overlay

Vice Chair Edmondson called on Angelina Jones, Lead Planner, for an update on the resolution to support a Zoning Ordinance Text Amendment to clarify and improve the existing process of the Historic District Review Board to grant setback reductions within the Historic District Overlay.

Ms. Jones provided an update and highlighted the portion of Town Code that would be updated with the proposed Zoning Ordinance Text Amendment. Staff is requesting that the Historic District Review Board recommend approval of the ZOTA.

There was discussion among the Board Members and staff on this item, including: (1) how this Zoning Ordinance Text Amendment will benefit the board and residents; (2) clarification on what the Board will be authorized to do under the proposed ZOTA; and (3) clarification on the process if an applicant wants to go under the 20-foot setback.

Board Member Fetske motioned to approve the resolution to support a Zoning Ordinance Text Amendment to clarify and improve the existing process of the Historic District Review Board to grant setback reductions within the Historic District Overlay. Motion seconded by Board Member Oleinick. The question was called on the motion, which was approved by a 6-0 roll call vote. Board Members Chowdhury, Fetske, LeReche, Oleinick, O'Savio, and Vice Chair Edmondson voted "Aye." Chair Leslie Blaker-Glass was absent.

6. Adjournment

There being no further business, and without objection, Vice Chair Edmondson adjourned the October 15, 2025, Historic District Review Board regular meeting at 7:46 p.m.

Amanda E.M. Kertz
Town Clerk

Minutes approved by Historic District Review Board: _____

[Note: Approved resolutions and ordinances are on file in the Department of Community Development.]



**Historic District Review Board
Regular Meeting
Agenda Item 3.c.**

Agenda Item: December 3, 2025, Historic District Review Board Work Session Minutes

Meeting Date: January 21, 2026

Category: Approval of Minutes

Prepared by: Amanda Kertz, Town Clerk

Description:

This is a request to approve the December 3, 2025, Historic District Review Board Work Session Minutes.

Background/Timing Impact:

N/A

Fiscal Impact:

N/A

Legal Impact:

Code of Virginia Section 2.2-3707 outlines the requirements for the recording of minutes for all public bodies.

Staff Recommendation/Next Steps:

Recommend approval as presented.

Attachments:

1. December 3, 2025, HDRB Draft Work Session Minutes

HERNDON HISTORIC DISTRICT REVIEW BOARD
Work Session Minutes
Wednesday, December 3, 2025

1. Call to Order

Chair Blaker-Glass called the December 3, 2025, Historic District Review Board work session to order at 7:02 p.m. in the Herndon Council Chambers Building, 765 Lynn Street, Herndon, Virginia. Board Members in attendance were: Melody Fetske, Paul LeReche, Amy Oleinick, Vice Chair Lauren Edmondson, and Chair Leslie Blaker-Glass.

Board Member Tamim Chowdhury was absent.

Staff present during the meeting: Lauri Sigler, Deputy Town Attorney; Angelina Jones, Lead Planner; Becky Skillin, Deputy Town Clerk; and Aaron Zoellick, Clerk of Boards and Commissions.

Chair Blaker-Glass determined there was a quorum with five members present.

2. New Business

a. Discussion Item - 781 & 783 Station Street, Rear Addition

Chair Blaker-Glass recognized Ms. Jones for the staff presentation.

Angelina Jones, Lead Planner, delivered the staff memo and staff presentation dated December 3, 2025, which are on file with the Department of Community Development.

There was discussion among the Board Members and staff on this item regarding the differences between design options one and two.

Chair Blaker-Glass invited the applicant's representative, Michael Wijdoogen, to provide comment.

There was discussion among the Board Members, staff, and the applicant's representative on this item, including: (1) owner's preference for Option One, including keeping the current temporary structure during the transition; and associated weather, cooling, and heating challenges; (2) Option Two's ability to accommodate outdoor seating year-round and to distinguish between the two spaces; (3) previously proposed options that included breaking through a wall and adding garage door style entrances; (4) material and roofing options, including altering the roof slope to add more differentiation and reduce costs; (5) current

zoning, building code, and egress considerations; (6) options for drainage and ADA access; (7) potential to design the structure to be enclosure-ready; and (8) clarification on current violations and potential removal.

3. Comments

a. Comments from the Staff Members

Ms. Sigler stated that the Historic District Review Board will receive security training at the December 17, 2025, regular meeting.

b. Comments from the Board Members

No comments were offered.

4. Adjournment

There being no further business, and without objection, Chair Blaker-Glass adjourned the December 3, 2025, Historic District Review Board work session at 7:53 p.m.

Amanda E.M. Kertz
Town Clerk

Minutes approved by Historic District Review Board: _____

Agenda Item: APPLICATION FOR NEW CONSTRUCTION, HDRB #25-005, 106 Monroe Hill Court, Herndon, Virginia, to consider an application for a Certificate of Appropriateness to construct a new accessory structure

Meeting Date: January 21, 2026

Category: Public Hearings

Prepared by: Angelina Jones, Lead Planner / Design and Development

Description:

Project Summary: This application proposes to erect a greenhouse at the subject property northeast of the dwelling within the property's secondary front yard (note that the greenhouse is already installed). The structure measures approximately 13.33' x 18' or 240 square feet in area. The overall design and roof configuration mirror that of the associated dwelling. The greenhouse features a side-gabled roof with a front-facing cross gable above the entrance. The building is clad in LP Smart vertical panel siding (engineered wood) and features a corrugated roof, partially clad in metal with the majority clad in an unspecified transparent material. The door is made of pine and the windows are a mix of four-over-one and two-over-one with simulated divided lites. For more information, please see the January 7, 2026, staff report.

Background/Timing Impact:

Work Session Discussion:

Board and Staff provided the following feedback at the January 7, 2026, work session:

- The board discussed the site constraints as outlined in the staff report and agreed that the applicant had limited options for appropriate locations to site their accessory structure on the property. Therefore, the board agreed in this instance that siting the structure in view of the Monroe Hill Court right-of-way would be appropriate.
 - The applicant further explained that they received a variance to erect a fence on the property that will obscure the view of the greenhouse from the right-of-way. The applicant plans to submit an application for a Certificate of Appropriateness for this fence shortly. Staff confirmed that fences can generally be approved administratively within the HDO.

Updates Since Work Session:

- Staff updated the draft resolution to stipulate that although the pre-fabricated greenhouse structure uses alternative materials that typically would not be appropriate for use within view from the right-of-way in the HDO, such as a synthetic resin/polymer material for the clear roof cladding, that in this particular instance the HDRB has found it to be appropriate due to the constraints presented by the lot configuration of this subdivision.

Summary of Zoning Ordinance Compliance and Conformance with the HDO Guidelines:

For this application, the applicable standards and requirements of the zoning ordinance are stated in Section 78-60.3(f)(2) - New construction and the applicable guidelines are in Chapter 6 – Use of Alternative Materials in the HDO and Chapter 9 - Guidelines for New Construction – New Construction of Accessory Structures.

Staff find that the proposal generally conforms to both the standards in the Zoning Ordinance and the HDO guidelines. The architectural front of the house faces Monroe Street and the proposed location for the accessory structure is at the traditional rear of the house. Therefore, the accessory structure will be sited in a manner that reflects the traditional location for similar structures and will not negatively impact the integrity of the contributing dwelling. The proposed accessory structure is constructed of alternative materials using contemporary techniques, thus ensuring that it will not be confused with a historic structure. The proposed location for the prefabricated accessory structure is highly visible from the right-of-way. However, the HDRB agreed that due to the lot configuration of this subdivision, there are no viable locations for siting the accessory structure on the subject property that is completely obscured from the right-of-way.

For additional information, please see the January 7, 2026, HDRB work session staff report and accompanying Historic District Overlay Guidelines Review Matrix.

Fiscal Impact:

N/A

Legal Impact:

N/A

Staff Recommendation/Next Steps:

Staff recommend approval of the application in accordance with the conditioned draft resolution.

Attachments:

1. Resolution (Proposed)
2. Materials
3. Legal Ad
4. Presentation

**TOWN OF HERNDON, VIRGINIA
HISTORIC DISTRICT REVIEW BOARD**

RESOLUTION

JANUARY 21, 2026

Resolution- to approve a Certificate of Appropriateness for HDRB #25-005 to permit construction of a new accessory structure at 106 Monroe Hill Court, Herndon, Virginia, located northeast of the intersection of Monroe Hill Court and Monroe Street and further identified as Fairfax County Tax Map 0104 44 0003.

BE IT RESOLVED by the Historic District Review Board of the Town of Herndon, Virginia that:

1. The Historic District Review Board approves a Certificate of Appropriateness for HDRB #25-005, to permit construction of a new accessory structure at the single-family residential building located at 106 Monroe Hill Court, Herndon, Virginia, in substantial conformance with the information shown in the case materials reviewed by the HDRB at the January 21, 2026, public hearing meetings and with the following conditions:
 - a. Although the pre-fabricated greenhouse structure uses some alternative materials that typically would not be appropriate for use within view from the right-of-way in the Historic District Overlay, the site and materials are appropriate in this particular application due to the constraints presented by the lot configuration of this subdivision.
 - b. The applicant shall provide updated application materials documenting the material specifications of the accessory structure's roofing and windows to staff for staff approval and to add to the case record.

FOLK VICTORIAN
1870-1910

Our House



Character-defining features

- Front- or side-gabled roof
- Stamped or standing seam metal roofs are common
- I- or L-shaped building forms
- Full- or partial-width front porch
- Architectural details are usually limited to simplified details on porches



Our Greenhouse

Roof: Black metal and clear metal

Siding: White LP smart panel

Door: 3' pine

Windows: (8) 24 x 48 Black

(5) 24 x 36 Black

Floor: Trex

Workbench: 12'

Painted Interior

Sited on 6" gravel pad



Greenhouse Site

Pad in Yellow

Main 12' x 18'

Bumpout 16" x 10"

Building corners in Pink

Main 10' x 16'

Bumpout 16" x 8'

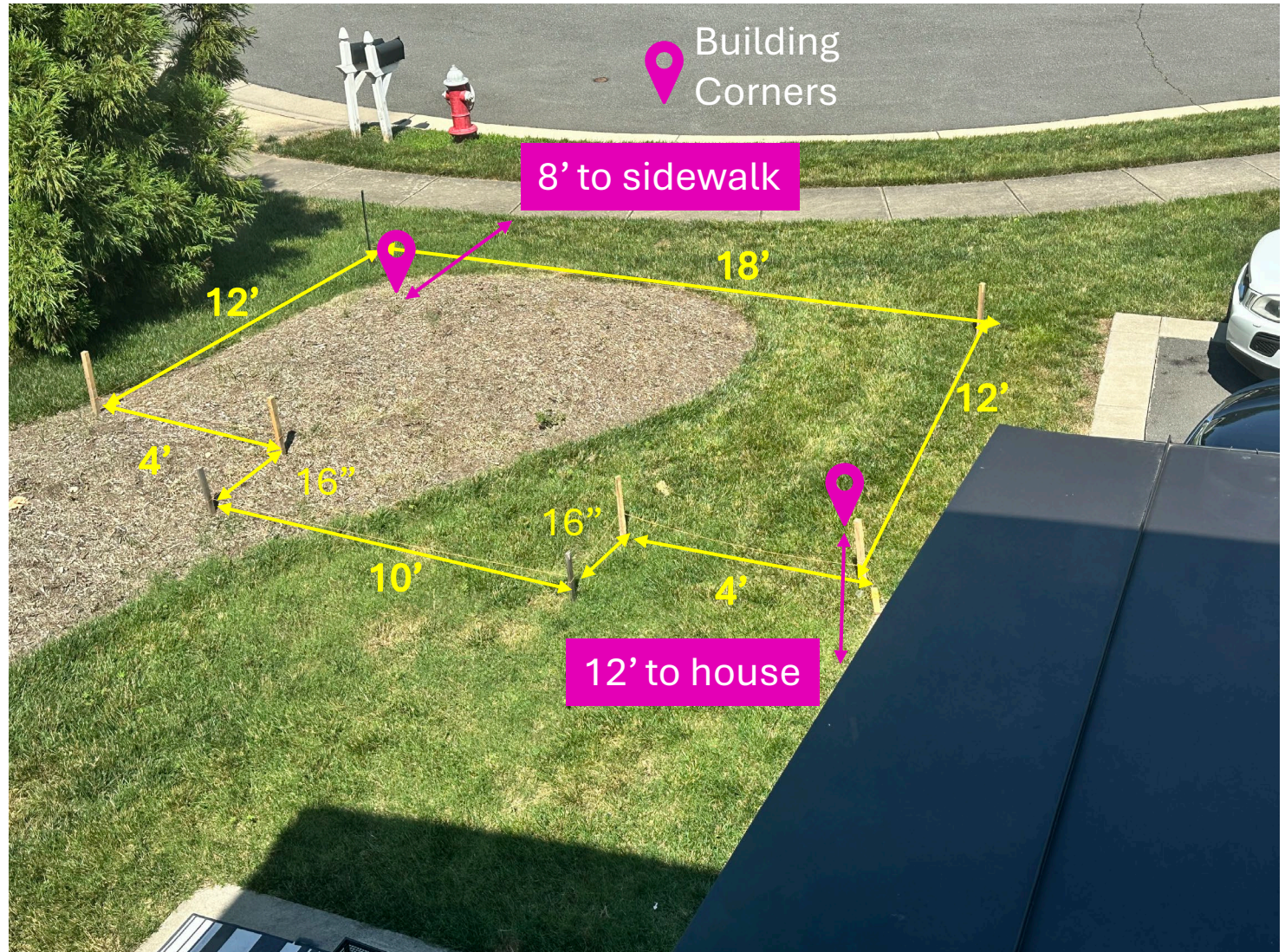
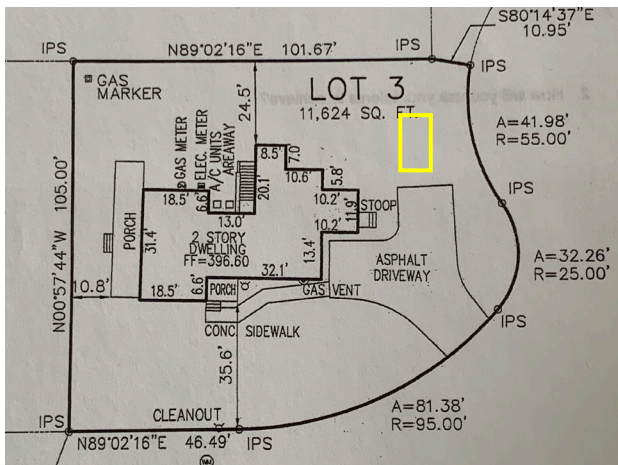

E	SIZE	SIDING
Greenhouse	10x16	LP Smart Panel

BUILDING DETAILS: Please re

- Trex Flooring
- Remove 5' double door Clea
- 3' Single door
- Pine door upgrade
- 28x41 Wood Sash Window
- Bumpout peak dormer
- Remove 24x36 windows
- (8) 24x48 Black Windows Leveli
- (5) 24x36 Black Windows
- Extra window trim
- 12' Greenhouse Workbench
- Metal roof
- Clear roof upgrade
- Painted Interior

=====

0 - Total Options

approves building description and terms on front and b

COMMENTS





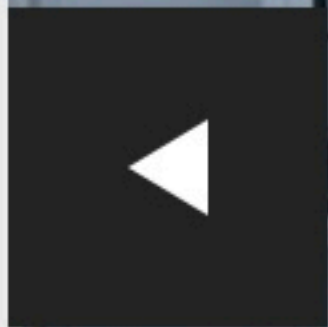

**Town of Herndon Survey
Fairfax County, Virginia**

Surveyor: EHT Traceries (B. Marzella)

Date: August 31, 2017

Street #: 106 Street Name: Monroe Hill Court DHS ID#: 235-0003-0130

Primary Resource Property Name (if any): Previously surveyed as 820 Monroe Street

Resource Category: Domestic Resource Type: Single Family Dwelling
 Construction Date: 1860 Circa VDHR Time Period: Antebellum Period (1830-1860)
 Contributing Status: Contributing Condition: Good Style: Folk Victorian
 Bldg. Type: T-Shaped Bays: 3 Stories: 2

Primary Cladding Material: Primary Treatment: Siding, Lap Primary Material: Vinyl

Secondary Cladding Material: Secondary Treatment: None Secondary Material: N/A

Roof Type: Gable w/Central Front Gable Roof Material: Metal, standing seam
 Chimney Type: Interior Central Chimney Treatment: Stretcher Bond Chimney Material: Asphalt
 Dormer Type: Gable Dormer Material: Vinyl
 Foundation Type: Solid/Continuous Found'n Treatment: Uncoursed Found'n Material: Stone
 Porch Type: 1-Story Full-Width Support Type: Square Posts Floor Material : Wood
 Window Type: Double-Hung Glazing Type: 1/1 True Window Material: Vinyl
 Shutter Type: Fixed Shutter Treatment: Louvered Shutter Material: Vinyl
 Garage Type: None Garage Treatment: N/A No. of Bays: N/A

Describe the following features, where present:

Main Entry Door: Paneled wood door with central oval opening and transom above

Front Porch: One-story, four-bay porch with hipped standing seam metal roof. Chamfered wood posts with decorative eave brackets and spindle works cornice. No railings

Signs and/or Murals: None



Photograph - Primary Elevation(s)

Describe the following features, where present:

Details or Character-Defining Features:

Vernacular house with mix of Carpenter Gothic and Folk Victorian influences including general form, fenestration, decorative porch features, spindle work, brackets and posts. Prominent front gable with central window.

Major Additions and/or Alterations:

Substantial two-story rear addition, date unknown. Remodeled circa 2014 with material replacement, vinyl siding and windows. Once part of larger dairy farm, property was subdivided circa 2014 with contemporary suburban houses developed around.

(Note location, size, & date)



Photograph - Secondary Elevations or Details

Secondary Resource #1

Resource Type: None Condition: —

Construction Date: —

Stories: — Bays: —

Resource Description:

(Note location, size, and distinctive features)

Photograph - Secondary Resource(s)

Primary Cladding Material: Primary Treatment: — Primary Material: —

Secondary Cladding Material: Secondary Treatment: — Secondary Material: —

Roof Type: — Roof Material: —

Chimney Type: — Chimney Treatment: — Chimney Material: —

Foundation Type: — Found'n Treatment: — Found'n Material: —

Porch Type: — Support Type: — Floor Material: —

Window Type: — Glazing Type: — Window Material: —

Additional Resources

Resource Description:

(Note location, type, & appearance)

**Town of Herndon, Virginia
Notice of Public Hearing**

Notice is hereby given that the **Historic District Review Board (HDRB)** of the Town of Herndon, Virginia, will hold a public hearing on Wednesday, January 21, 2026, at 7:00 p.m. in the Herndon Council Chambers Building, located at 765 Lynn Street, Herndon on the following items:

APPLICATION FOR NEW CONSTRUCTION, HDRB #25-005, to consider an application for a Certificate of Appropriateness to construct a new accessory structure at 106 Monroe Hill Court, Herndon, Virginia, located east of the intersection of Monroe Hill Court and Monroe Street. The subject property is further identified as Fairfax County Tax Map 0104 44 0003, is zoned R10, Residential Single Family-10 District, and consists of 11,624 square feet of land. Applicant: Patricia P. Kelly. Property Owner: Patricia Kelly.

APPLICATION FOR AN ALTERATION, HDRB #25-011, to consider a Certificate of Appropriateness to modify the front entrance of the building at 783 Station Street, Suite A, Herndon, Virginia, located on the northeast side of Station Street between the intersections with Pine Street and Lynn Street. The subject property is further identified as Fairfax County Tax Map 0162 02 0301D, is zoned PD-D Planned Development – Downtown District and consists of 5,904 square feet of land. Applicant: Michael Wijdoogen, MW Architects, LLC. Property Owner: James Building Development, LLC.

The public is encouraged to participate in the town’s public hearing process. Individuals having an interest in the above items are invited to attend the public hearing and state their opinions and may also submit comments to hdrb.arb@herndon-va.gov.

The proposed items are available for examination at the Department of Community Development, 777 Lynn Street, Herndon, during normal business hours (Monday – Friday) and available for review by the public on the town’s website www.herndon-va.gov.

The Town of Herndon supports the Americans with Disabilities Act by making reasonable accommodations for persons with disabilities so that they may participate in services, programs, or activities, offered by the town. Please call (703) 435-6804 to arrange for any accommodation that may be necessary to allow participation.

Amanda Morrow Kertz, Town Clerk

Note to Publisher:

Publish on January 2, 2026/January 9, 2026

Historic District Review Board

January 21, 2026, Regular Meeting

HDRB #25-005 – Application for New Construction



Historic District Context

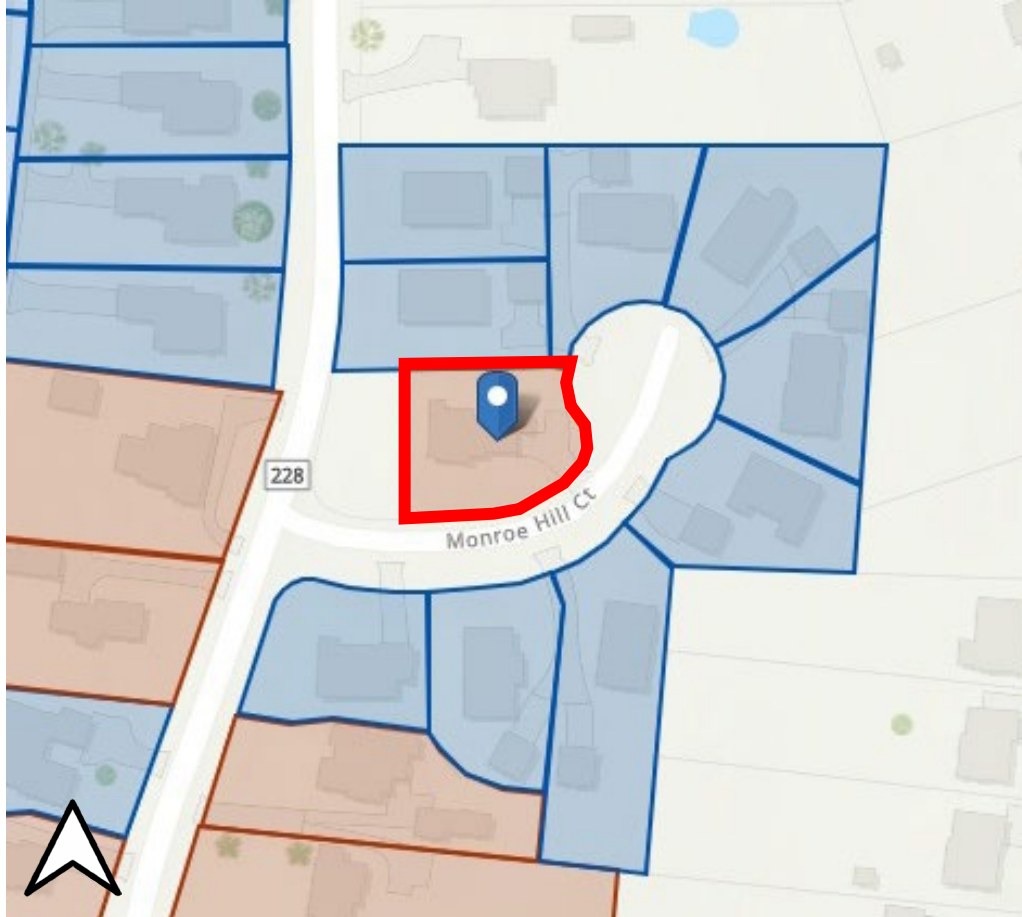

Facing northwest

Historic District Context



Dwelling at 106 Monroe Hill Court

Historic Conditions

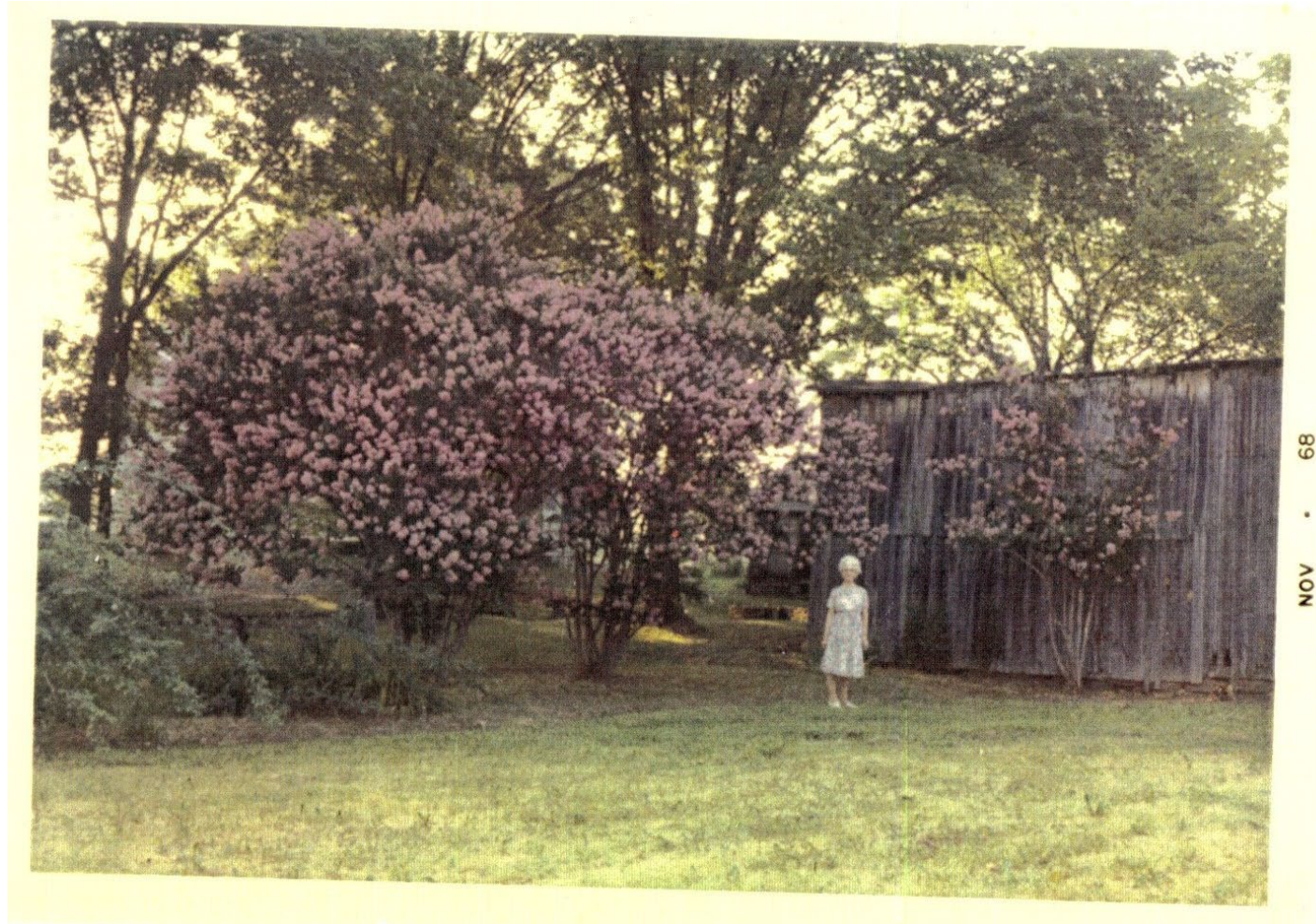

Image of no longer extant carriage house associated with the subject property, 1968

Source: Herndon Historical Society

Existing Conditions



Facing northwest



Facing west

Installed Design

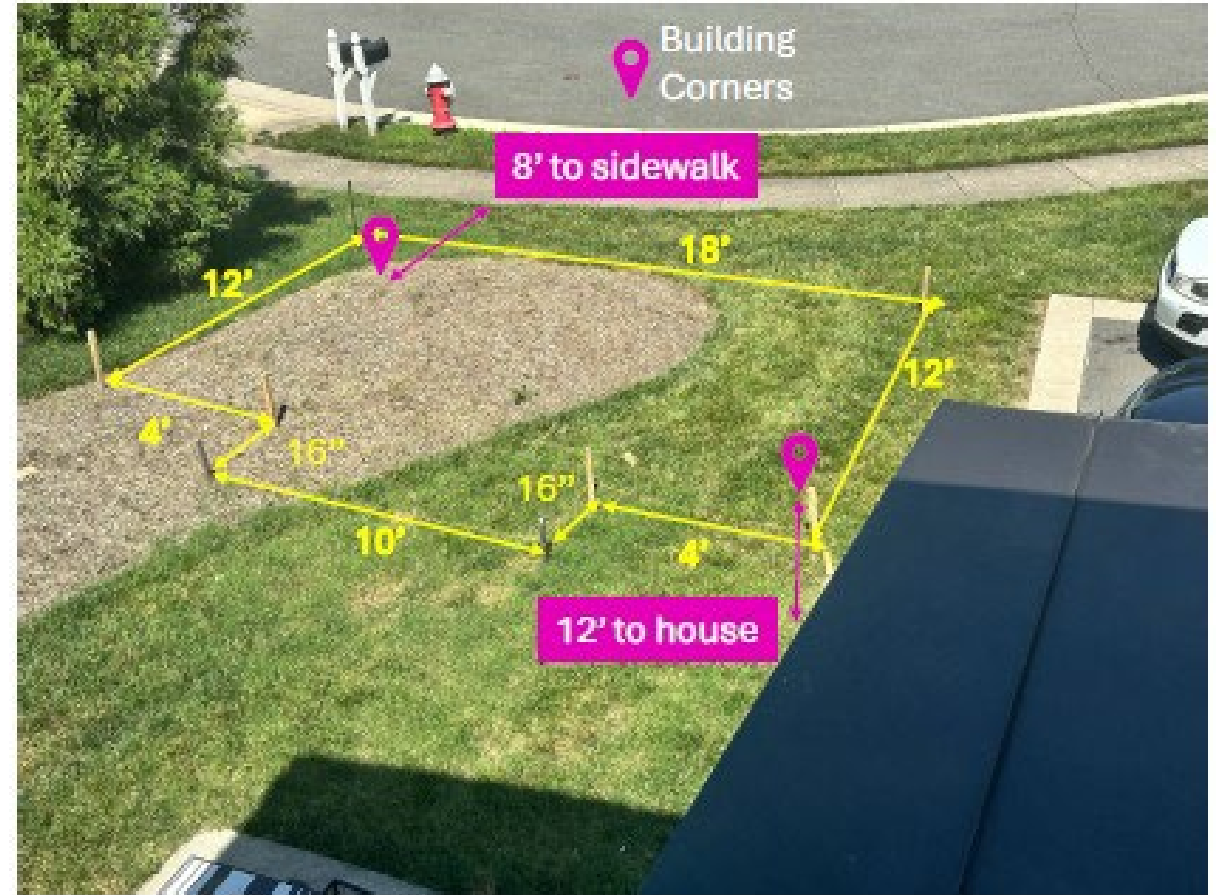

Staff Analysis

- Architectural front of the house faces Monroe Street
 - Greenhouse therefore sited at traditional rear of dwelling
- Accessory structure is constructed of alternative materials using contemporary techniques
 - Will not be confused with a historic structure
- Location visible from the Monroe Street right-of-way
 - No viable locations for siting the accessory structure out of view of right-of-way

Updates

- Staff updated the draft resolution
 - Acknowledges unusual lot configuration for siting accessory structure
- Roof is a corrugated, polycarbonate
- Windows are aluminum (frame and mullions)

- Staff recommend approval in accordance with the conditioned draft resolution

Historic District Review Board

January 21, 2026, Regular Meeting

HDRB #25-005 – Application for New Construction



Agenda Item: APPLICATION FOR AN ALTERATION, HDRB #25-011, 783 Station Street, Suite A, Herndon, Virginia, to consider a Certificate of Appropriateness to modify the front entrance of the building

Meeting Date: January 21, 2026

Category: Public Hearings

Prepared by: Angelina Jones, Lead Planner / Design and Development

Description:

Project Summary: This application proposes to modify the existing double glass doors and transom at the subject property. The applicant seeks to replace this existing framing system with an aluminum storefront placed within the decorative pediment. The existing interior paving beneath the pediment is to be replaced with a concrete slab to allow the anchoring of the proposed replacement door. For more information, please see the January 7, 2026, staff report.

Background/Timing Impact:

Work Session Discussion:

Board and Staff provided the following feedback at the January 7, 2026, work session:

- The applicant explained that they wanted to move the location of the interior door from the extant recessed position to the entry of the pediment to prevent detritus from entering the enclosure.
- The applicant brought revised drawings that would maintain the symmetry of the entryway by eliminating the sidelite that was in the initial proposal. The revised design also replaced a glass transom with a wooden insert ornamented with raised strips to create a sunburst detail. The revised design would center the door between two solid panels to maintain the symmetry of the façade.
- The applicant stated that they wanted the door to be wood, fiberglass, or aluminum and that if aluminum were selected, they would use a white anodized finish.
- The board supported the use of wood, fiberglass, or aluminum, but stated the aluminum should be anodized white rather than clear (silver).
- The board stated that the revised design addressed concerns pertaining to symmetry and material detailing for a contributing commercial building.

Updates Since Work Session:

Following the work session, the applicant submitted the updated materials via email and

confirmed the following:

- Proposed door is Kawneer 190 Narrow Stile aluminum storefront door system with white, anodized finish measuring 3'-0" W x 8'-0".
- The conditioned resolution states that modifications to the entry of the contributing commercial building at the subject property are appropriate as the alteration is to a rehabilitated feature on the building rather than material that dates to the period of significance. Furthermore, the resolution requires the applicant to submit material samples of the anodized aluminum (including hardware) and the tempered glass for final staff approval, as well as specifying that the hardware (handle) be brass colored.

Summary of Zoning Ordinance Compliance and Conformance with the HDO Guidelines: For this application, the applicable standards and requirements of the zoning ordinance are stated in Section 78-60.3(f)(1) - Standards for Alterations and the applicable guidelines are in Chapter 5 – Treatment of Contributing Buildings – Windows, Exterior Doors and Associated Features and Chapter 6 - Use of Alternative Materials in the HDO. Staff find that the proposal generally conforms to both the standards in the Zoning Ordinance and the HDO guidelines.

While the building is a contributing resource within the historic district, the doors proposed for replacement post-date the historic district's period of significance. The current decorative pediment is of a similar overall style and design as the one in place during the historic period. Due to the change in this aspect of the building's design, a new replacement design is appropriate under the rehabilitation treatment standard, provided that the design does not negatively impact the overall symmetry and balance along the building's façade, as this symmetry is a character-defining feature typical of the neoclassical style. The revised design preserves the building's overall symmetry and employs detailing that generally does not detract from the neoclassical character of the contributing building. Staff advise that the applicant provide material samples of the aluminum framing system with the intended coating and the tempered glass demonstrating the intended tinting to ensure that the finishes will complement the detailing of the decorative pediment. Staff recommend that hardware be in an anodized brass-colored finish. The glass tinting should be transparent enough to not appear dark or black from the right-of-way.

For additional information, please see the January 7, 2026, HDRB work session staff report and accompanying Historic District Overlay Guidelines Review Matrix.

Fiscal Impact:

N/A

Legal Impact:

N/A

Staff Recommendation/Next Steps:

Staff recommend approval of the application in accordance with the conditioned draft resolution.

Attachments:

1. Resolution (Proposed)
2. Additional Materials
3. Legal Ad
4. Presentation

**TOWN OF HERNDON, VIRGINIA
HISTORIC DISTRICT REVIEW BOARD**

RESOLUTION

JANUARY 21, 2026

Resolution- to approve a Certificate of Appropriateness to modify the front entrance of the building at 783 Station Street, Suite A, Herndon, Virginia, located on the northeast side of Station Street between the intersections with Pine Street and Lynn Street and further identified as Fairfax County Tax Map 0162 02 0301D.

BE IT RESOLVED by the Historic District Review Board of the Town of Herndon, Virginia that:

1. The Historic District Review Board approves a Certificate of Appropriateness for HDRB #25-011, to permit alterations to the front entrance at the commercial building located at 783 Station Street, Suite A, Herndon, Virginia, in substantial conformance with the information originally reviewed by the ARB at the January 7, 2026, work session and modified by the materials reviewed by the ARB at the January 21, 2026, public hearing and with the following conditions:
 - a. Although doors of contributing buildings are typically character defining features, the doors proposed for replacement in this case post-date the historic district's period of significance, therefore, it is appropriate for the doors to be modified as a rehabilitation that uses limited contemporary elements, but also employs traditional detailing and materials to ensure overall compatibility with the neoclassical architecture of the building.
 - b. The selected hardware shall be of a brass-colored, anodized finish.
 - c. The glass of the door system shall be transparent and not tinted to the extent that it appears black from the right-of-way.
 - d. The applicant shall coordinate with staff to select appropriate
 - i. glazing and finishes, including associated hardware, for the
 - ii. storefront system prior installation.
 - e. The applicant shall provide material samples to staff for staff approval, to verify compliance with the conditions, and to add to the case record.

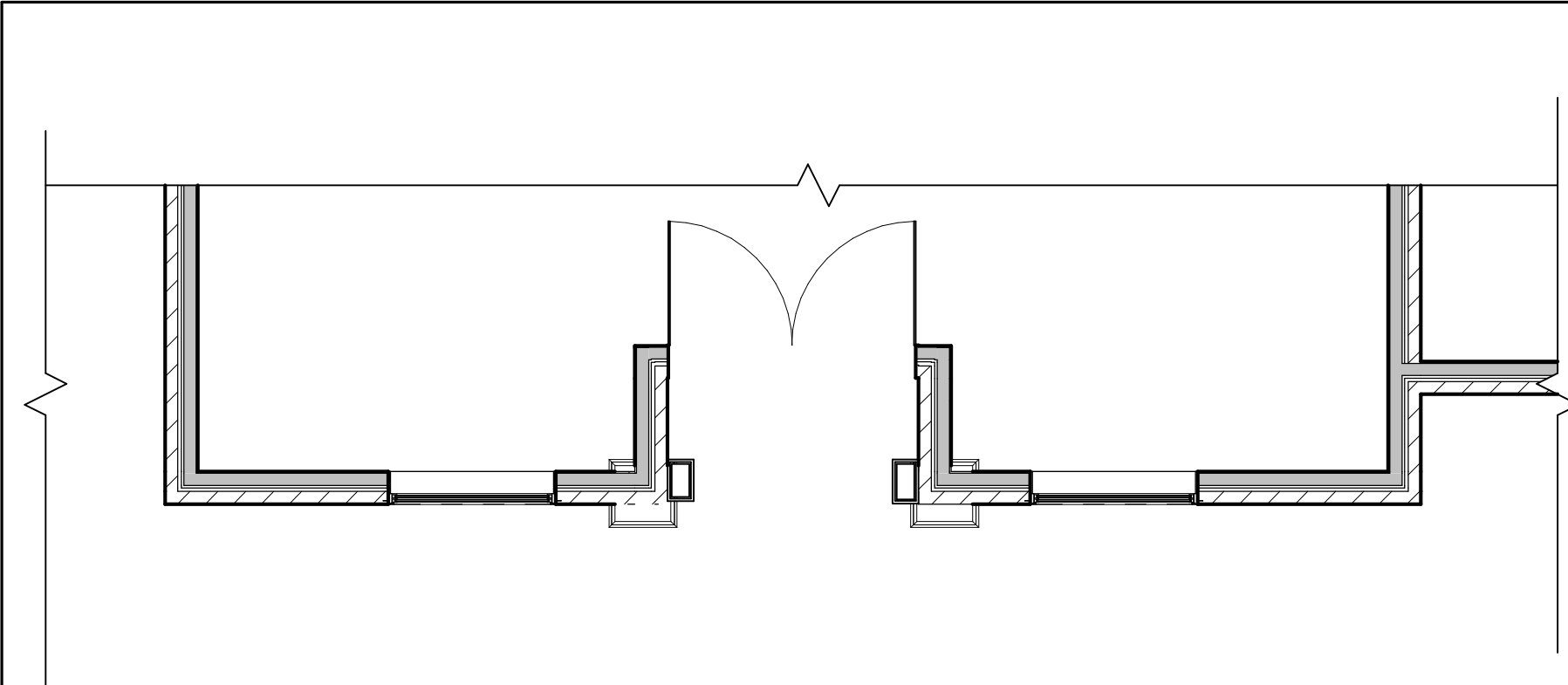

1. EXISTING FIRST FLOOR PLAN
1/4" = 1'-0"

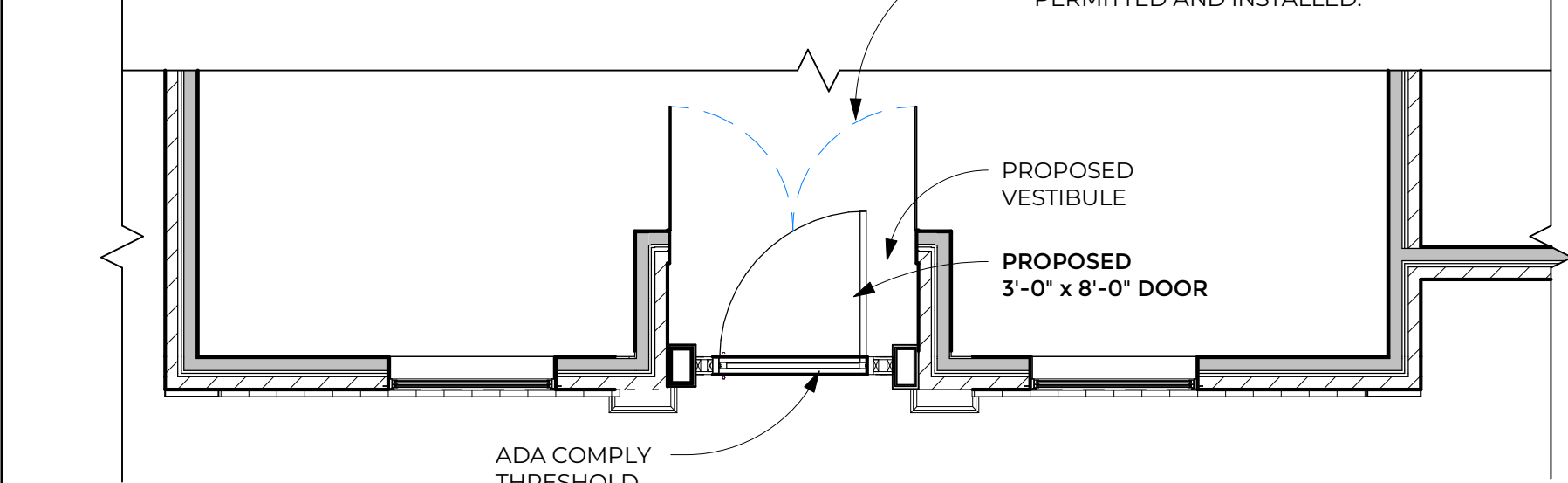

2. PROPOSED FIRST FLOOR PLAN
1/4" = 1'-0"

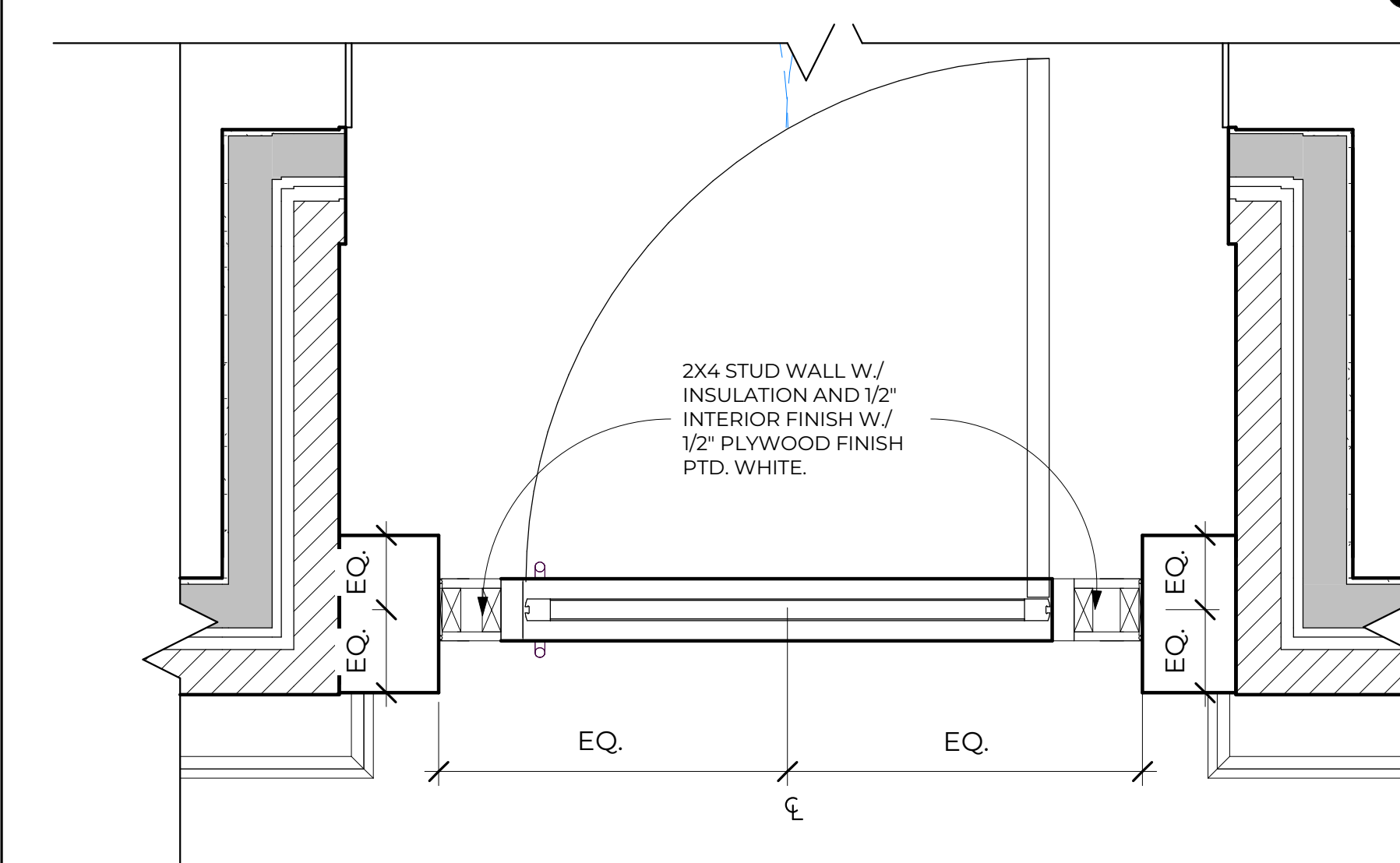

3. EXISTING FRONT ELEVATION
1/4" = 1'-0"

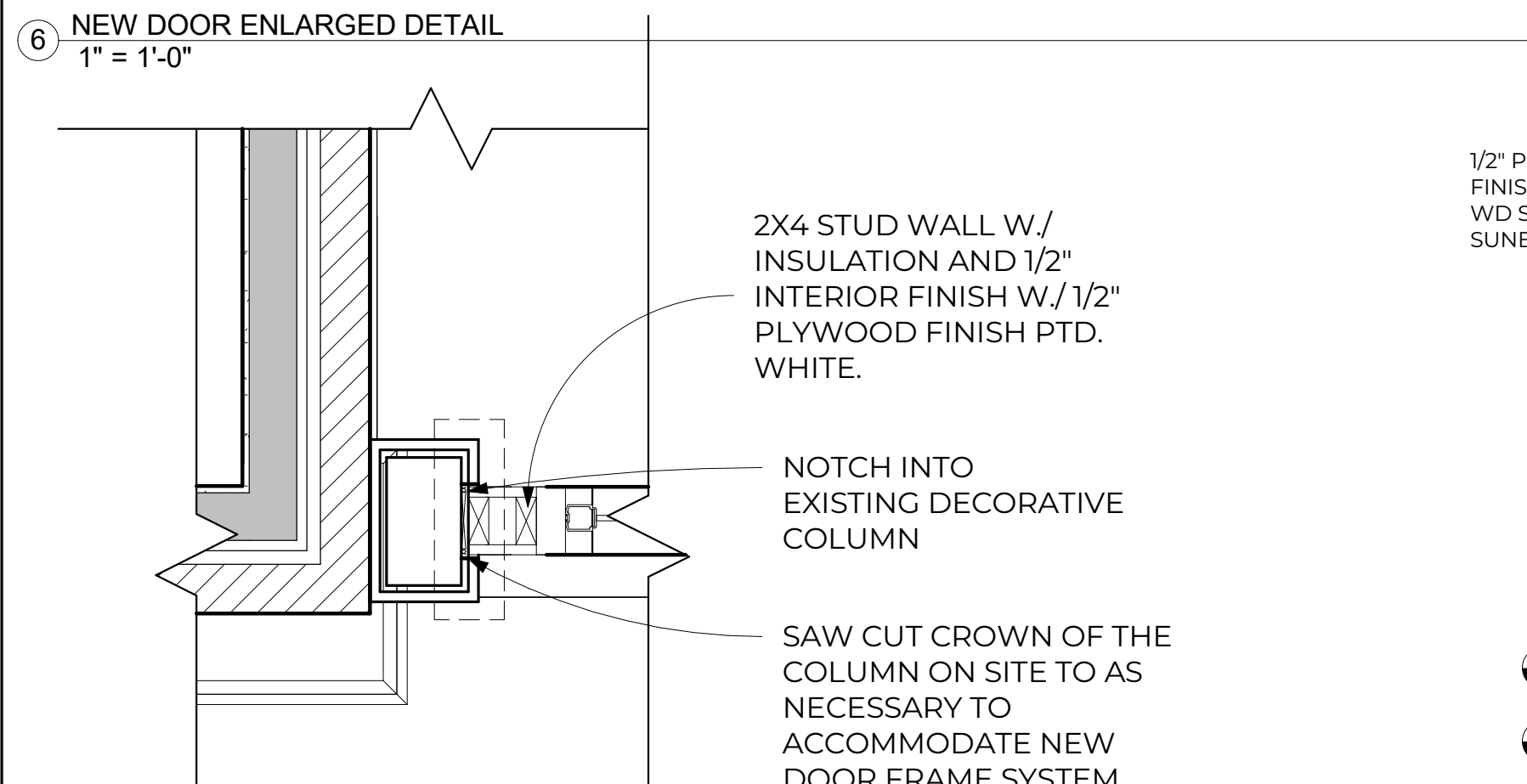

6. NEW DOOR ENLARGED DETAIL
1" = 1'-0"



7. DETAIL AT CROWN
1" = 1'-0"



3. EXISTING FRONT ELEVATION
1/4" = 1'-0"

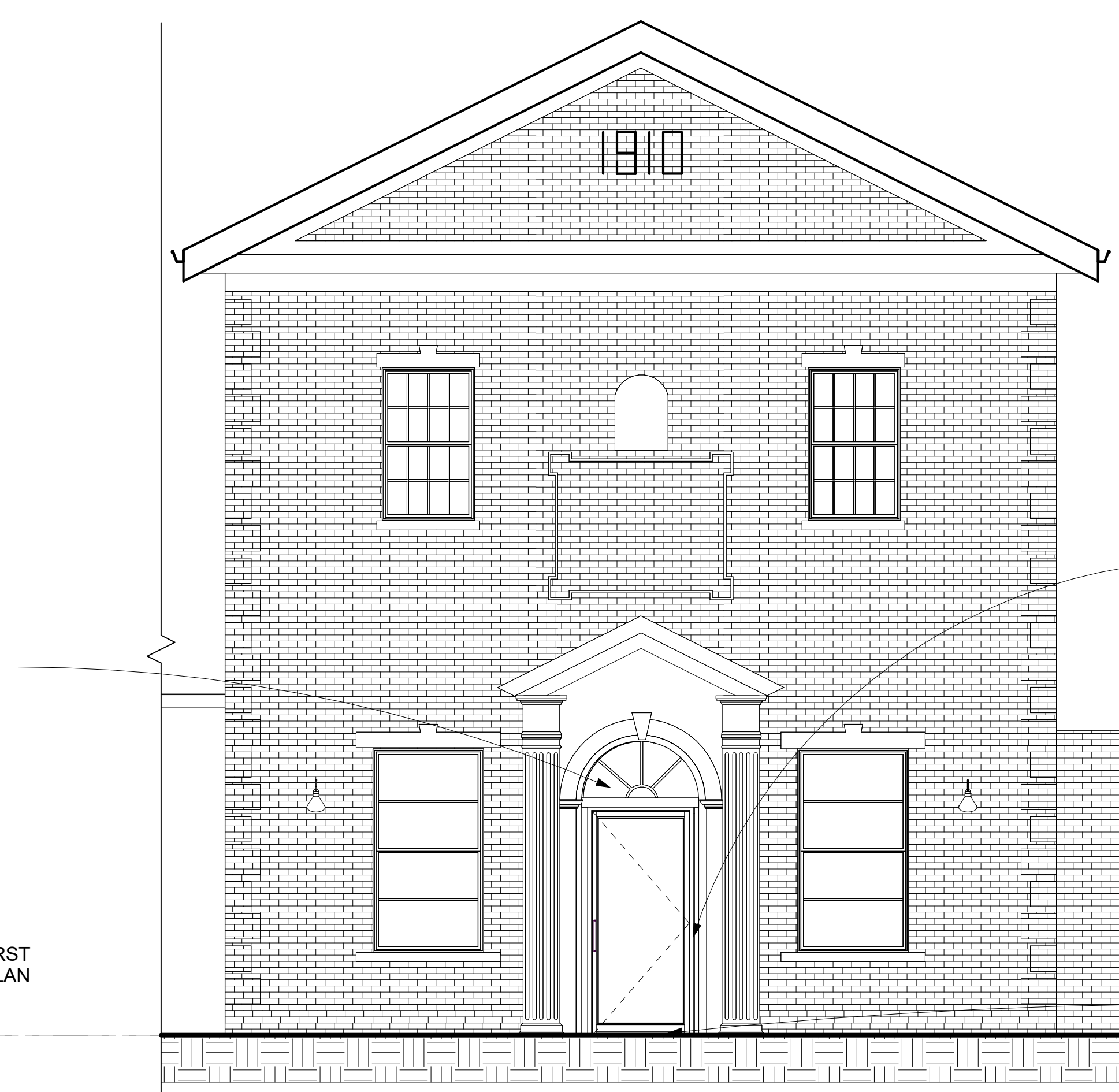

4. PROPOSED FRONT ELEVATION
1/4" = 1'-0"



5. PROPOSED 3D

- FURNISH AND INSTALL AS ITEMS LISTED.
- ONE (1) 3'-0" X 8' KAWNEER 190 NARROW STILE ALUMINUM WHITE FINISH, ENTRANCE DOOR AND ARCH TO FIXED FRAMING.
 - DOOR HARDWARE TO BE, MS 1850A DEADLOCK WITH EXTERIOR CYLINDER AND INTERIOR THUMBTURN, 9" EXTERIOR PUSH BAR AND 9" INTERIOR VERTICAL PULL, 10" ADA BOTTOM RAIL ON DOOR, 1 1/2" PAIR OF BUTT HINGES, BOTTOM RAIL WEATHERING, 4" X 1/2" ADA THRESHOLD, AND SURFACE MOUNTED CLOSER.
 - ALL ALUMINUM TO BE WHITE ANODIZED FINISH.

EXISTING BRICK FINISH TO REMAIN AND EXISTING WALK OFF GRATE TO REMAIN. GRATE AND PORTION OF BRICK TO BE INTERIOR FINISHES.

MW
ARCHITECTS
"Architecture with a scaled & constructive approach"
761C Monroe Street, Suite 201
Herndon, VA 20170
(833)-819-9461
www.mwarchitects.com

HIGHLAND TITLE
783 Station St Suite A,
Herndon, VA 20170

PROJECT NUMBER:	25.241
DATE:	01/08/26
DRAWN BY:	EN
CHECKED BY:	MSW
REVISIONS:	
HDRB: 12/09/2025	
HDRB: 01/07/2026	

SEAL:

SCALE:	As indicated
SHEET TITLE:	EXISTING & PROPOSED PLANS & ELEVATIONS & 3D
SHEET NUMBER:	A1.0

**Town of Herndon, Virginia
Notice of Public Hearing**

Notice is hereby given that the **Historic District Review Board (HDRB)** of the Town of Herndon, Virginia, will hold a public hearing on Wednesday, January 21, 2026, at 7:00 p.m. in the Herndon Council Chambers Building, located at 765 Lynn Street, Herndon on the following items:

APPLICATION FOR NEW CONSTRUCTION, HDRB #25-005, to consider an application for a Certificate of Appropriateness to construct a new accessory structure at 106 Monroe Hill Court, Herndon, Virginia, located east of the intersection of Monroe Hill Court and Monroe Street. The subject property is further identified as Fairfax County Tax Map 0104 44 0003, is zoned R10, Residential Single Family-10 District, and consists of 11,624 square feet of land. Applicant: Patricia P. Kelly. Property Owner: Patricia Kelly.

APPLICATION FOR AN ALTERATION, HDRB #25-011, to consider a Certificate of Appropriateness to modify the front entrance of the building at 783 Station Street, Suite A, Herndon, Virginia, located on the northeast side of Station Street between the intersections with Pine Street and Lynn Street. The subject property is further identified as Fairfax County Tax Map 0162 02 0301D, is zoned PD-D Planned Development – Downtown District and consists of 5,904 square feet of land. Applicant: Michael Wijdoogen, MW Architects, LLC. Property Owner: James Building Development, LLC.

The public is encouraged to participate in the town’s public hearing process. Individuals having an interest in the above items are invited to attend the public hearing and state their opinions and may also submit comments to hdrb.arb@herndon-va.gov.

The proposed items are available for examination at the Department of Community Development, 777 Lynn Street, Herndon, during normal business hours (Monday – Friday) and available for review by the public on the town’s website www.herndon-va.gov.

The Town of Herndon supports the Americans with Disabilities Act by making reasonable accommodations for persons with disabilities so that they may participate in services, programs, or activities, offered by the town. Please call (703) 435-6804 to arrange for any accommodation that may be necessary to allow participation.

Amanda Morrow Kertz, Town Clerk

Note to Publisher:

Publish on January 2, 2026/January 9, 2026

Historic District Review Board

January 21, 2026, Regular Meeting

HDRB #25-011 – Application for an Alteration



Historic District Context



Facing northwest

Historic Conditions

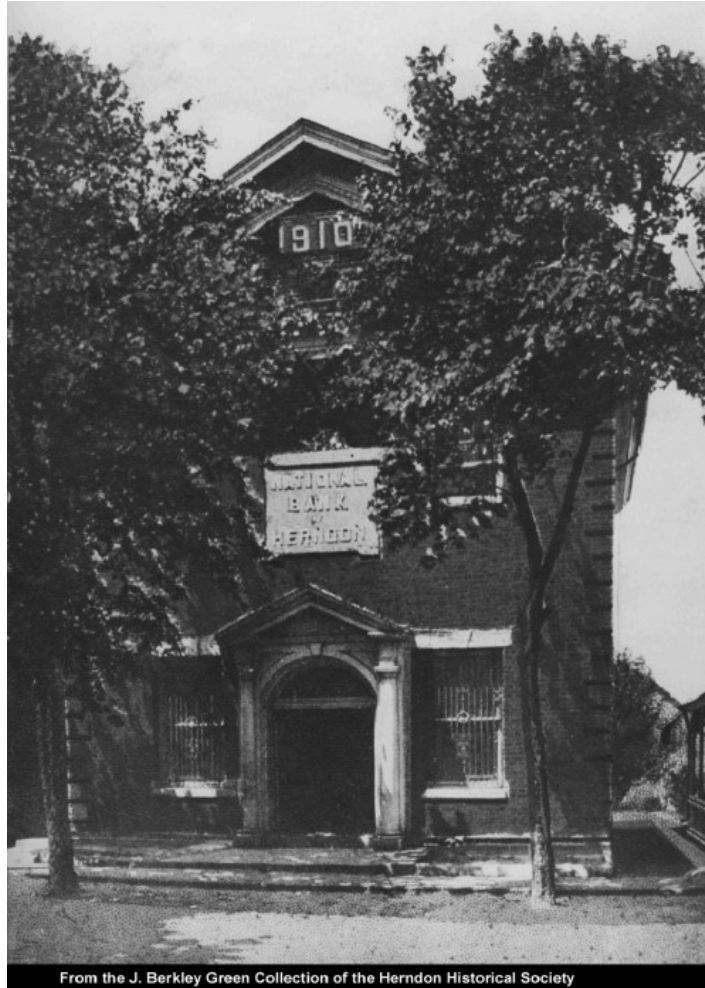

Façade between 1935 and early 1960s



Façade in 1988

Historic Conditions



From the J. Berkley Green Collection of the Herndon Historical Society

Façade 1930s



Detail

Existing Conditions



Facing southwest



Facing west

Existing Conditions



EXISTING FIRST FLOOR PLAN
0' - 0"
GRADE
0' - 0"

③ EXISTING FRONT ELEVATION
1/4" = 1'-0"

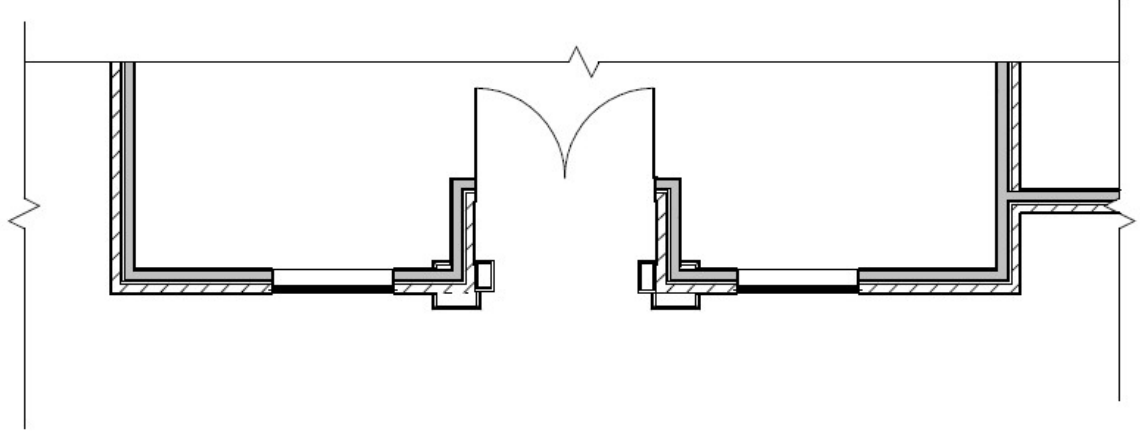

① EXISTING FIRST FLOOR PLAN
1/4" = 1'-0"

Proposed Design



⑤ PROPOSED 3D

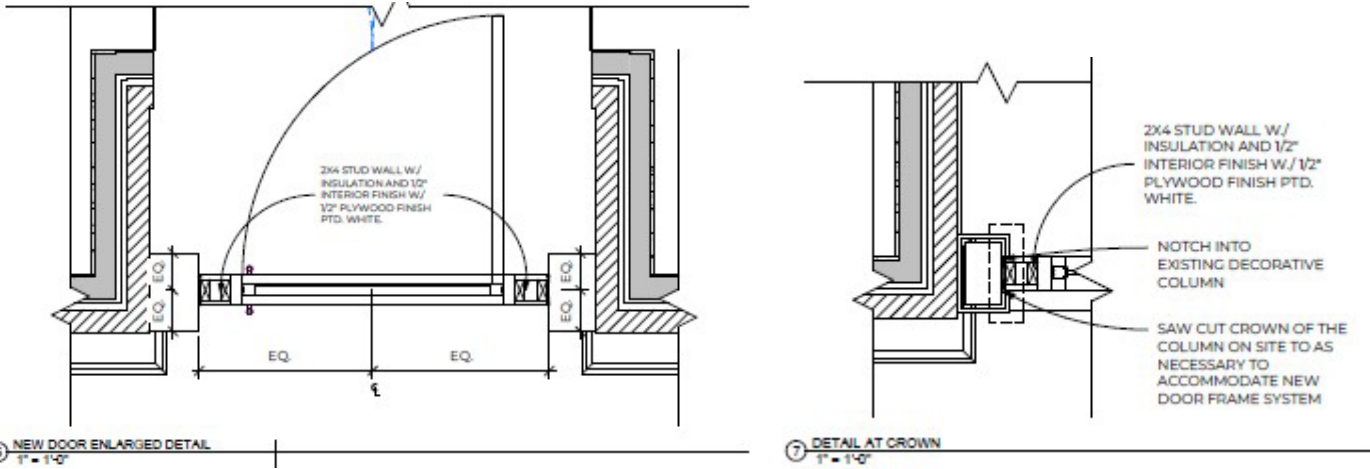

⑥ NEW DOOR ENLARGED DETAIL
1" = 1'-0"

⑦ DETAIL AT CROWN
1" = 1'-0"

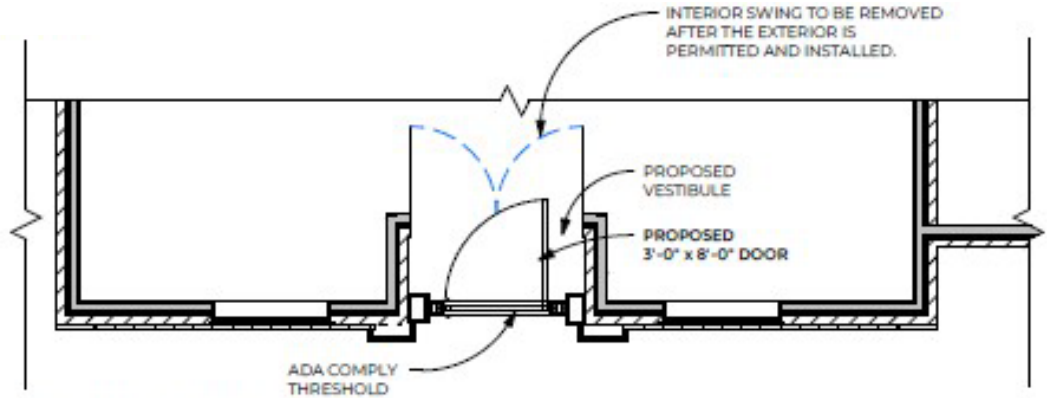

② PROPOSED FIRST FLOOR PLAN
1/4" = 1'-0"

Proposed Design

SCALE 3" = 1' 0"

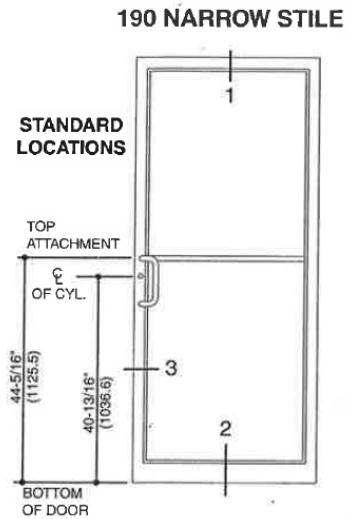
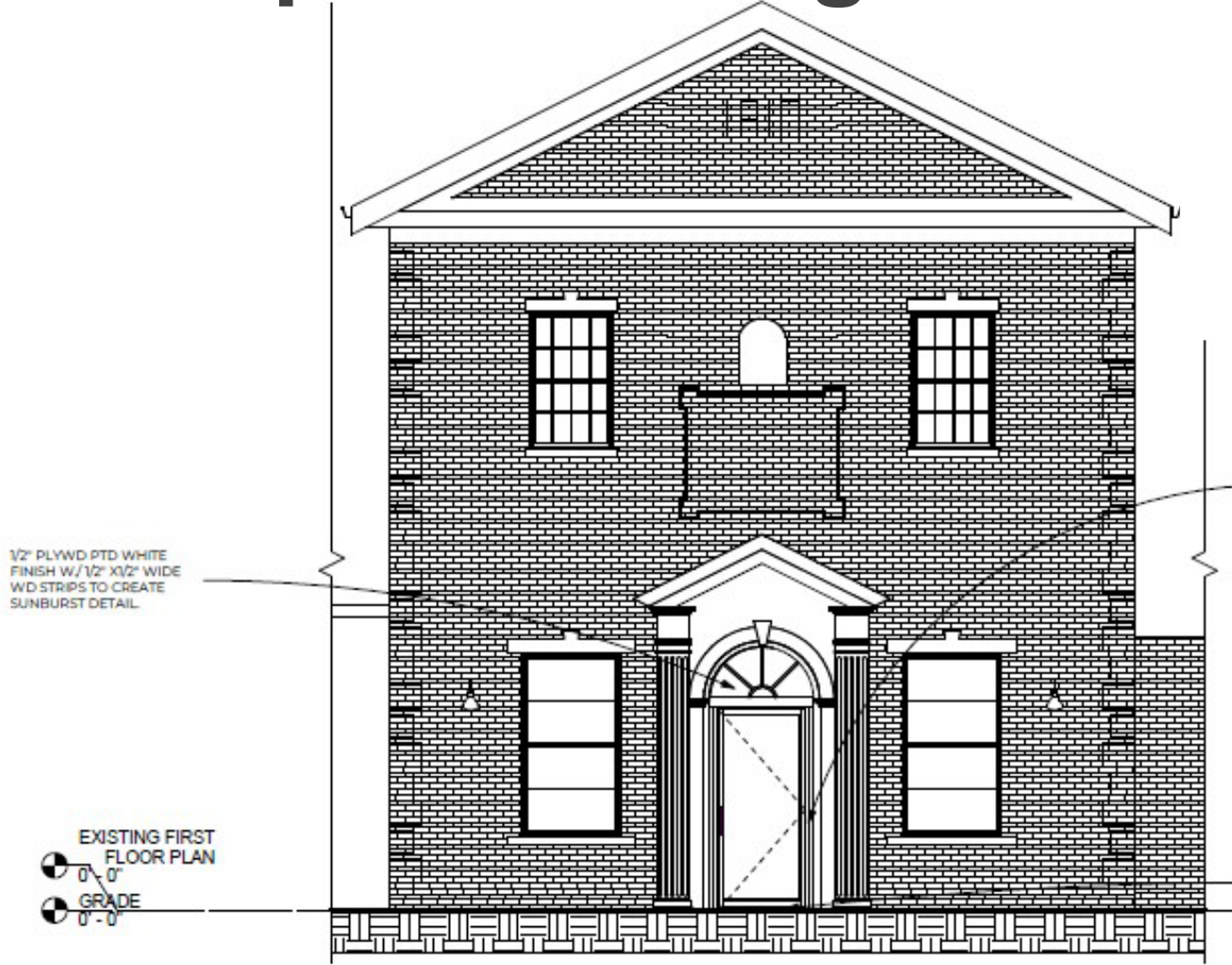

- FURNISH AND INSTALL AS ITEMS LISTED.
- ONE (1) 3'-0" X 8' KAWNEER 190 NARROW STILE ALUMINUM WHIT FINISH. ENTRANCE DOOR AND ARCH TO FIXED FRAMING.
 - DOOR HARDWARE TO BE, MS 1850A DEADLOCK WITH EXTERIOR CYLINDER AND INTERIOR THUMBTURN, 9" EXTERIOR PUSH BAR A 9" INTERIOR VERTICAL PULL, 10" ADA BOTTOM RAIL ON DOOR, 1 1/2" PAIR OF BUTT HINGES, BOTTOM RAIL WEATHERING, 4" X 1/2" ADA THRESHOLD, AND SURFACE MOUNTED CLOSER.
 - ALL ALUMINUM TO BE WHITE ANODIZED FINISH.

EXISTING BRICK FINISH TO REMAIN AND EXISTING WALK OFF GRA REMAIN. GRATE AND PORTION OF BRICK TO BE INTERIOR FINISHE

4 PROPOSED FRONT ELEVATION
1/4" = 1'-0"

Staff Analysis

- Building is a contributing resource within the historic district
 - However, doors proposed for replacement post-date the period of significance
 - Appropriate to consider a new replacement design under rehabilitation treatment standard
 - New design should not negatively impact overall symmetry and balance
- Symmetry of façade is a character defining feature

Updates

- Proposed door - 190 Narrow Stile aluminum with white, anodized finish
- Updated proposal maintains a symmetrical arrangement along the façade
 - Design uses traditional detailing in combination with contemporary materials
- Conditioned resolution:
 - Describes that doors post-date the period of significance
 - States that outstanding design details will be coordinated by staff with applicant
 - Specifies that hardware should be of a brass-colored, anodized finish
 - Requires transparent glass
 - States that the applicant provide material samples
- Staff recommend approval in accordance with the conditioned draft resolution

Historic District Review Board

January 21, 2026, Regular Meeting

HDRB #25-011 – Application for an Alteration

